

N/C

Parks and Recreation Facilities

GUIDELINES

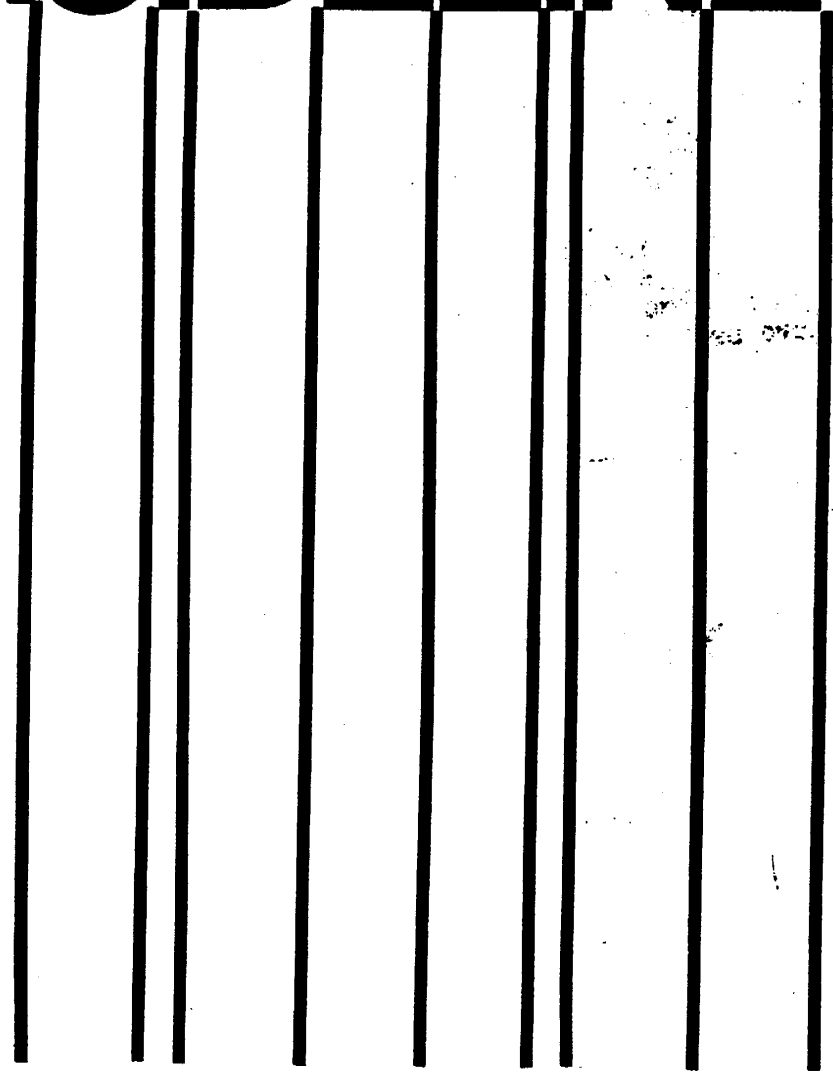

**THE MARYLAND NATIONAL CAPITAL
PARK and PLANNING COMMISSION**

Department of Parks and Recreation

6600 Kenilworth Avenue Riverdale, Maryland 20737

APPROVED JULY 1, 1983

THE MARYLAND-NATIONAL CAPITAL PARK AND PLANNING COMMISSION

COMMISSIONERS

Charles A. Dukes, Jr., Chairman

Norman L. Christeller, Vice Chairman

Edwin H. Brown

Mable Granke

John H. Cumberland

Judith Heimann

Edgar Burton Keller, Jr.

Betty Ann Krahnke

Ann Shoch

Sheldon P. Schuman

Prince George's County Planning Board

Montgomery County Planning Board

Department Heads

Thomas H. Countee, Jr.
Executive Director

A. Edward Navarre
Secretary-Treasurer

John F. Downs, Jr.
Planning Director
Prince George's County

Richard E. Tustian
Planning Director
Montgomery County

Hugh B. Robey
Director of Parks and Recreation
Prince George's County

Stanton G. Ernst
Director of Parks
Montgomery County

Robert D. Reed
Public Affairs Manager
Prince George's County

John Hoover
Community Relations Manager
Montgomery County

Prince George's County Regional Office
14741 Governor Oden Bowie Drive
Upper Marlboro, Maryland 20772

Montgomery County Regional Office
8787 Georgia Avenue
Silver Spring, Maryland 20907

Prepared by: Grace E. Fielder
Planning, Design & Research Division
Department of Parks and Recreation
6600 Kenilworth Avenue
Riverdale, Maryland 20737

TABLE OF CONTENTS

FOREWORD -----	1
COMMENT SHEET (TO BE FILLED OUT & RETURNED)-----	3

SUBDIVISION AND ZONING REVIEW POLICIES:

General -----	5
Dedication of Parkland -----	6
Payment of Fee in Lieu -----	7
Recreational Facilities -----	8

PROCESSING PROCEDURES

General Planning Design Statement -----	11
Subdivision Processing Requirements -----	
Preliminary Plat/Comprehensive Design Plan -----	11
Site Plan/Specific Design Plan -----	13
Recreational Facilities Agreements -----	
Recreation Facility Agreement -----	13
Agreement to Amend -----	19
Agreement to Rescind -----	22
Financial Guarantees -----	25
Performance Bond -----	26
Escrow Account -----	29
Letter of Credit -----	30
Payment of Fee in Lieu -----	32
Site Inspections -----	32
Violations -----	32
GENERAL RECREATION DESIGN -----	33

FACILITIES:

Playgrounds: -----	39
Tot Lot -----	
Pre-Teen Lot -----	
Park -----	
Sitting Area -----	53
Passive -----	
Urban -----	
Picnic Area -----	57
Subdivision -----	
Park -----	
Open Play Area -----	61
Basketball Court and Multi-Purpose Court -----	71
Tennis Court(s) -----	85
Softball Field -----	99
Subdivision -----	
Park -----	

TABLE OF CONTENTS

Baseball Field-----	111
Soccer Field -----	123
Football/Soccer Field Combination -----	135
Football Field -----	147
Trails-----	159
Paths	
Subdivision	
Fitness and Running	
Nature	
Park	
Equestrian	
Hiking	
Bike	
LANDSCAPING -----	173

ILLUSTRATIONS

ILLUSTRATION #	CHAPTER	TITLE	PAGE
2.1	Processing Procedures	Level of Detail Preliminary/ Comprehensive Design Plan	12
2.2	Processing Procedures	Level of Detail Site/Specific Design Plan	14
3.1	General Recreation Design	Typical Land Use Plan for Parks, Recreation Facilities and Open Space	34
3.2	General Recreation Design	Typical Central Recreation Area	35
3.3	General Recreation Design	Typical Developed Satellite Open Space	37
4.1	Playgrounds	Typical Hand Sizes for Children	41
4.2	Playgrounds	Schematic Playground - Pre-teen	43
4.3	Playgrounds	Typical Tot-Lot & Pre-teen Area Siting	45
4.4	Playgrounds	Tot-Lot Example B Page 48	47
4.5	Playgrounds	Pre-teen Area Example A Page 50	49
5.1	Sitting Area	Typical Urban Sitting Area	54
5.2	Sitting Area	Typical Natural Sitting Area	54
5.3	Sitting Area	Typical Sitting Area for Central Recreation Area	55
6.1	Picnic Area	Typical Picnic Area	58
6.2	Picnic Area	Cross Section	59
7.1	Open Play Area	Typical Open Play Area	62
8.1	Basketball/Multi-Purpose Court	Orientation	71
8.2	Basketball/Multi-Purpose Court	Typical Multi-Purpose Court Siting	82

ILLUSTRATIONS

ILLUSTRATION #	CHAPTER	TITLE	PAGE
9.1	Tennis Courts	Orientation	85
9.2	Tennis Courts	Typical Tennis Court Siting	86
10.1	Softball	Orientation	99
10.2	Softball	Typical Softball Field Siting	100
11.1	Baseball	Orientation	111
11.2	Baseball	Typical Baseball Field Siting	112
12.1	Soccer	Orientation	123
12.2	Soccer	Typical Soccer Field Siting	124
13.1	Soccer/Football	Orientation	135
13.2	Soccer/Football	Typical Soccer/Football Siting	138
14.1	Football	Orientation	147
14.2	Football	Typical Football Siting	148
15.1	Trails	Trail Signage	164
Not Numbered	Landscaping	Design Principles	173-176

DETAIL INDEX

CHAPTER	DETAIL TITLE	DETAIL NO.
Playgrounds	Cross Section and Plan View of Edging	A1
Picnic Area	Wooden Picnic Tables	B1
Picnic Area	Picnic Table Anchors	B2
Picnic Area	Trash Receptacle	B3
Open Play Area	Plan View and Drainage	C1
Basketball	Plan View Full Court	D1
Basketball	Plan View Half Court	D2
Basketball	Plan View 4 Backstop	D3
Basketball	Plan View 6 Backstop	D4
Basketball	Multi Purpose Court	D5
Basketball	Cross Section Paving	D6
Basketball	Backboard	D7
Basketball	Fencing	D8
Basketball	Drainage	D9
Tennis	Plan View Single Court	E1
Tennis	Plan View Double court	E2
Tennis	Cross Section, Net and Paving	E3
Tennis	Fence	E4
Tennis	Drainage	E5
Softball	290' Softball Field Layout	F1
Softball	275' Soft Field Layout	F2
Softball	Nonhooded Backstop	F3
Softball	Hooded Backstop	F4
Softball	Hood & Fence Post Footings	F5
Softball	Base Layout	F6
Softball	Drainage	F7



DETAIL INDEX

CHAPTER	DETAIL TITLE	DETAIL NO.
Softball	Combination Field Overlays	F8
Baseball	Field Layout	G1
Baseball	Hooded Backstop	G2
Baseball	Backstop and Fence Post Footings	G3
Baseball	Base Layout	G4
Baseball	Drainage	G5
Soccer	Field Layout	H1
Soccer	Children's Field Layout	H2
Soccer	Goal Post and Footings	H3
Soccer	Drainage	H4
Soccer	Combination Field Overlays	H5
Soccer	Football Field Layout	I1
Soccer Football	Goal Post and Footing	I2
Soccer Football	Drainage	I3
Soccer Football	Combination Field Overlays	I4
Football	Field Layout	J1
Football	Goal Post and Footing	J2
Football	Drainage	J3
Football	Combination Field Overlays	J4
Trails	Paving Cross Sections	K1
Trails	Clearing Cross/Section	K2
Trails	Curb Ramp, Stopping Distance	K3
Trails	Special Removable Bollard	K4
Landscaping	Shade and Evergreen Tree Planting	L1
Landscaping	Shrub Planting	L2



FORWARD

This publication is a compilation of Department of Parks and Recreation's (DPR) existing policies, procedures, standards and specifications presently used as guidelines for the provision of parks, recreational facilities and open spaces on parkland and private recreation development in Prince George's County.

The provision of safe parks and recreation facilities is the joint responsibility of the public and private sector. It would be unrealistic to believe that we can prevent all injuries, but it is not unrealistic to provide safe facilities that have been carefully designed and constructed that if used properly and with supervision will not cause unnecessary injury. These guidelines have been prepared with user safety in mind.

The publication will not be a "mandate" or "rubric" for the provision of land, facilities or fee. It will, however, be a guide to be utilized during the land development process. It is a basis on which we can begin to build and expand. The DPR has and will continue to review all proposals and encourage the development of new and different facilities within the parks and in subdivisions.

A cross section of participants in the land development process will be served by this publication, including attorneys, builders, developers, architects, landscape architects, engineers, construction foremen and administrators. For the first time since the original mandatory dedication ordinance went into effect in Prince George's County, Maryland in April of 1971, a much needed continuity to the entire mandatory dedication process will exist.

These guidelines, as they exist today, are a beginning. Additional items may be reviewed and included in future guidelines, such as:

- Playground Safety
- Playground Maintenance
- Handicapped Facilities
- Senior Citizen Facilities
- Ancillary Facilities

- Horseshoes
- Shuffleboard
- Hopscotch
- Tetherball
- Racquetball (outdoor)

It is the intention of Prince George's County Planning Board and the Department of Parks and Recreation of The Maryland-National Capital Park and Planning Commission to continue a public private review of this document.

COMMENT SHEET

The Maryland-National Capital Park and Planning Commission has expended a great deal of effort to produce an appropriate and useable document for the parks and recreation industry. It is our desire to keep this document up to date and timely, we can do this with your assistance. The Department of Parks and Recreation invites you the user of the Park and Recreation Facilities Guidelines, to take the time to write down your thoughts, comments and even requests for new information and return them to the Department. These comments will be reviewed by the Review Committee and maybe included as amendments to the Guidelines.

Please provide the following information with your comments.

Your Name	Type of work your firm does
_____	_____
Company Name	_____
_____	_____
Address	_____
_____	_____
_____	Your position and/or profession
_____	_____
Phone	_____
_____	_____

Comments are to be sent to:

Department of Parks and Recreation
Maryland-National Capital Park and Planning Commission
6600 Kenilworth Avenue
Riverdale, Maryland 20737
Attn: Grace E. Fielder
Principal Planner

SUBDIVISION & ZONING REVIEW POLICIES

The Department of Parks and Recreation is applying the following guidelines and policies when reviewing preliminary plats of subdivision, zoning cases, Comprehensive Design Zones, and special exceptions. The majority of the preliminary plats reviewed by the Department of Parks and Recreation are subject to Sections 24-134 and 24-135 of the Subdivision Regulations of Prince George's County, Maryland.

The primary intent of the mandatory dedication section of the Subdivision Regulations is to acquire parkland through the subdivision process and to provide the residents of the new subdivision with light, air, open space, recreational and trail opportunities.

POLICIES OF DEPARTMENT OF PARKS AND RECREATION

- A. General
1. To review any proposals for the provision of Parks and Recreation and Open Space.
 2. To utilize ~~Section 24-134~~ of the Subdivision Regulations to provide parks, recreation facilities and open space to the residents of the subject property being developed.
 3. To use Section 24-134 of the Subdivision Regulations to enhance the existing parks, recreation and open spaces already provided in a neighborhood.
 4. To obtain easements for the county-wide hiker/biker and equestrian trails as established on the Adopted and Approved 1975 Trails Plan and as provided for in Section 24-123(5) of the Subdivision Regulations.
 5. To have an agreement with the Washington Suburban Sanitary Commission or an appropriate public agency that addresses the use, development and maintenance responsibilities of a facility whose primary function is storm water management prior to making a recommendation to the Planning Board that the land on which it is located be accepted as public parkland.
 6. To recommend the reservation of parkland where a park has been designated on a Master Plan or is determined to be needed to conform with the level-of-service program of the Parks, Recreation and Open Space Plan.
 7. To comment to the Urban Design Division on all open space configurations in cluster subdivisions that are not being dedicated to The Maryland-National Capital Park and Planning Commission.
 8. To acquire the maximum stream valley parkland as is designated on a Adopted Master Plan or as is a logical extension of an existing stream valley park and as provided for in Section 24-122(a)(5) of the Subdivision Regulations via purchase, donation or as a part of the mandatory dedication obligation.
 9. To require a performance bond or other suitable written financial guarantee for the restoration and completion of any grading, storm drain work, paving, utilities, etc., being done on parkland, or a rider to the benefit of the Department of Parks and Recreation on a bond or guarantee posted to another county agency.

10. To apply all guidelines and requirements for parks, recreation facilities, and open space to Comprehensive Design Zones.
11. To request that the Planning Board require landscaped and/or screened buffer areas on commercial, industrial, and office uses that adjoin parkland.

B. DEDICATION OF PARKLAND

1. To require the dedication of 5% of any land on which a density of one (1) to four (4) dwelling units per net acre is permissible; 7-1/2% of any land on which a density of four (4) to seven and one-half (7.5) dwelling units per net acre is permissible; 10% of any land on which a density of seven and one-half to twelve dwelling units per net acre is permissible; and 15% of any land on which a density exceeding twelve (12) dwelling units per net acre is permissible, as required by Section 24-134 of the Subdivision Regulations.
2. To require the land being dedicated to be above the 100-year floodplain, to have slopes less than 7%, the land to be useable for active recreation.
3. To require at least one suitable vehicular access to the land being dedicated by provision of a 60' frontage on a dedicated street or frontage as required by the Land Development Division.
4. To require all additional accesses to land being dedicated to be a minimum of 40'.
5. To place the following conditions on all land to be dedicated to the Department of Parks and Recreation:

CONDITIONS FOR DEDICATION OF LAND TO M-NCPPC

In accordance with Sections 24-134 and 24-135 of the Subdivision Regulations of Prince George's County, the Department of Parks and Recreation will recommend to the Planning Board that the following stipulations be required of the applicant, his successors and assigns, as conditions for subdivision approval:

1. The dedication to the Commission by special warranty deed of the acreage indicated on an approved preliminary plat to be submitted at time of final plat approval. This deed shall be accompanied by a receipt showing payment of all outstanding fees, charges, and taxes on the dedicated property.
2. The subdivider, his successors and assigns, shall be responsible and hold the Commission harmless for the cost of public improvements in existence at the time of conveyance or as required by developer's proposal associated with the land to be dedicated, including, but not limited to, sewer extensions, water lines, adjacent road construction,

storm drains, sidewalks, curbs and gutters, and redemption of front foot benefit charges both past and present.

3. The dedicated parkland shall not suffer the disposition of construction materials, soil filling, discarded plant materials, refuse or similar waste matter and all man-made debris shall be removed from land to be dedicated prior to dedication. The subdivider, his successors and assigns, shall notify the M-NCPPC Department of Parks and Recreation to inspect the land at time of dedication.
4. The subdivider, his successors and assigns, shall label all plans, from preliminary plat forward, boundaries of all lands to be dedicated to M-NCPPC. Plans include, but are not limited to, rough grading, water and sewer, sediment control, storm water management and storm drains, and site development drawings.
5. The subdivider, his successors and assigns shall not disturb in any way the land due in mandatory dedication without the expressed written consent of the Department of Parks and Recreation of the M-NCPPC. If the Department of Parks and Recreation agrees to the disturbance of the land, the subdivider, his successors and assigns, shall post a performance bond or other suitable written financial guarantee to warrant restoration, repair, or improvements made necessary or required by the M-NCPPC approval.
6. The subdivider, his successors and assigns, shall work with the Department of Parks and Recreation to develop storm drain outfalls that will not adversely affect land to be dedicated to the M-NCPPC. If the outfall will require any work within the park, a bond will be required of the subdivider, his successors and assigns to cover said work.

C. PAYMENT OF FEE IN LIEU

1. To recommend a fee in lieu of parkland dedication in the following cases:
 - a. The subject application adjoins existing or proposed parkland which can adequately meet the needs of the subdivision.
 - b. When the subject preliminary plat would produce less than one acre of ground and there is sufficient recreational facilities existing in the neighborhood to meet the needs of the subdivision's future residents.
 - c. When the land available within the subject application is unsuitable due to topography, soils, floodplains, or lack of suitable access to roads.

D. FACILITIES

1. To recommend approval of recreational facilities proposed on a plan of subdivision in place of mandatory dedication in accordance with Section 24-135(b)(1) when such facilities will be superior or equivalent to those that would have been provided under the provisions of mandatory dedication.
2. To require that recreational facilities be built to the Department of Parks and Recreation standards and specifications unless the applicant presents equal or better standards and specifications; ("equal or better" to be judged by the Department of Parks and Recreation).

PARK AND RECREATIONAL FACILITIES STANDARDS

3. To require that recreational facilities be clustered in central recreation areas accessible and convenient for 500 to 750 people. This area(s) is to be buffered by landscaping and minimum setback of 25' from dwelling lot lines, 30' from dwellings, and 30' from adjoining property lines.
4. Not to place recreational facilities in front of a dwelling.
5. To base the type and amount of recreational facilities on the projected population of the subdivision using the current population projections per dwelling unit, as developed by the Planning Department.
6. To utilize the following Recreational Facilities Standards in subdivision review:

Facilities are based on projected population.

- one (1) 2,400 square-foot tot lot per 500 persons.
 - one (1) sitting area per 500 persons.*
 - one (1) picnic area per 500 persons.*
 - one (1) 100'x200' open play area per 500 persons.
 - one (1) 5,000 square-foot pre-teen area per 750 persons.
 - one (1) 60'x90' basketball court per 750 persons.*
 - one (1) tennis court per 1,000 persons.
 - one (1) football/soccer field (225'x360") per 3,000 persons.
 - one (1) softball field (275' baseline) per 3,000 persons (if constructed on subdivision only)
 - one (1) softball field (295' baseline) per 3,000 persons (if constructed on parkland)
 - one (1) baseball field (hardball, 310' baseline and 350' centerfield) per 6,000 persons.
 - 4' wide hard-surfaced system of paths to connect facilities.
- *sitting, picnic and basketball court are frequently replaced with other facilities unless sited in a central recreation area.

7. To encourage the inclusion and substitution of unique facilities for the "traditional" standards required by the Department of Parks and Recreation that are acceptable to the Department and approved by the Planning Board.

8. To recommend to applicants of subdivision proposals that they work closely with the Department of Parks and Recreation to create recreation and open space opportunities for special populations such as senior citizens and handicapped.
9. To require site plans to include all construction details, spot elevations, etc. These plans will be used to set bond amounts for construction of recreational facilities and to inspect constructed facilities.
10. To recommend that a homeowners' association be established for the future care, maintenance, and retention of the recreational facilities not dedicated to the Commission.
11. To require a recreational facilities agreement between the landowner and the M-NCPPC to be recorded in the land records prior to final platting of the subdivision.
12. To require a performance bond or other suitable financial guarantee prior to issuance of building permits to assure the construction of recreation facilities.
13. To provide an applicant with a letter to the Veterans Administration or Federal Home Administration, or other public agency if requested by the applicant, to establish proof of bonding.

PROCESSING PROCEDURES

The following chapter is a revision of the guidelines as of November 1, 1984, reflecting a transfer of processing responsibilities to the Development Review Section. All Preliminary plans submitted prior to this date will be processed by the previous procedure. All preliminary plans submitted after November 1, 1984 will be processed by the revised procedure. (Numbers after 4-85001.)

GENERAL DESIGN STATEMENT

Successful construction of recreation facilities depends on the application of good design based on site planning principles. Experience has shown that the majority of new homeowners complaints regarding the construction of recreation facilities are caused by non-application of good planning principles such as:

- 1.) Facilities constructed too close to homes.
- 2.) Facilities lacking adequate buffering.
- 3.) Facilities too widely dispersed.
- 4.) Facilities located too close to roads and parking lots.

Recreation facilities should be considered as required site elements from the initial stages of preliminary project planning to achieve the best design solution.

In a multiple sectioned project, when phases are platted separately, each section should include an adequate recreation facilities package based on the facilities/population standards previously given.

The scheduling of facilities construction will depend on their size, the scope of facilities required, and their location within the development. Most facilities will be required to be built in phase with project construction. Each case is reviewed individually. Phasing is determined at the site plan or the specific design plan, and incorporated into the Recreation Facilities Agreement whenever possible.

SUBDIVISION PROCESSING REQUIREMENTS

Preliminary Plat/Comprehensive Design Plan

When a preliminary plat/comprehensive design plan is submitted for processing, a note is to be made on the plan to state explicitly what the developer's intent is regarding mandatory dedication. Under the subdivision ordinance the three options are the dedication of land for park purposes, fee-in-lieu of dedication, or the provision of private recreational facilities. The choice of these options is based on the recommendation of the Department of Parks and Recreation. This will bring the development into compliance with the Subdivision regulations. At the time the preliminary plat is approved by the Planning Board, specific conditions will be contained in a memorandum from the Department of Parks and Recreation be made a condition of approval.

If a fee is required, it is paid at the time the subdivision is recorded. Fee-in-lieu is equivalent to 5% of the assessed value of the property in the year prior to subdivision, as shown on the tax bill. If fee-in-lieu is to be paid the following note should be placed on the preliminary plan under the heading of general notes:

"It is the intent of the applicant to make a payment of fee-in-lieu at the time of final plat."

If land is to be dedicated, a deed free of front foot benefit charges and property taxes is to be brought to the Land Development Division at the time of filing the final plat.

Land dedication requirements are based on density per acre as follows:

<u>Units/Net Acre Permissible</u>	<u>Mandatory Dedication Requirement</u>
1 to 4 d.u.	5%
4 to 7.5 d.u.	7.5%
7.5 to 12 d.u.	10%
15 plus d.u.	15%

If it is the developer's intent to provide recreational facilities, a clear delineation of the type and size of the facilities and pedestrian path system is to be shown. A typical illustration of the level of detail for a Preliminary/Comprehensive Design Plan is shown on Page 13, Illustration #2.1.

The following is the Department of Parks and Recreation Facility Standards based on population: (populations = average number of inhabitants per dwelling unit X number of dwelling units):

<u>Facilities</u>	<u>Size</u>	<u>Quantity</u>	<u>Per Populations Nos.</u>
Tot Lot	2400 s.f.	1	per 500 persons
Sitting Area	200 s.f.	1	per 500 persons
Picnic Area	800 s.f.	1	per 500 persons
Open Play Area	100'x200'	1	per 500 persons
Pre-Teen Play Area	5000 s.f.	1	per 750 persons
Multi-purpose Court	60'x90'	1	per 750 persons
or			
1/2 Multi-purpose Court	60'x50'	1	per 375 persons
Tennis Court	60'x90'	1	per 1000 persons
Softball field	275' baseline	1	per 3000 persons
(Subsidision Only)			
Softball Field	295' baseline	1	per 3000 persons
(Parkland)			
Football/Soccer Field	225'x360'	1	per 3000 persons
Baseball Field	310' baseline	1	per 6000 persons
(Hardball)	350' center field		
Hard-surfaced Paths	As appropriate		As appropriate
Soft-surfaced Paths	As appropriate		As appropriate

In addition, hiker/biker and/or equestrian trails shown on the Adopted and Approved County-wide Trails Plans are to be provided for in conformance with Section 24-123(5) of the Subdivision Ordinance.

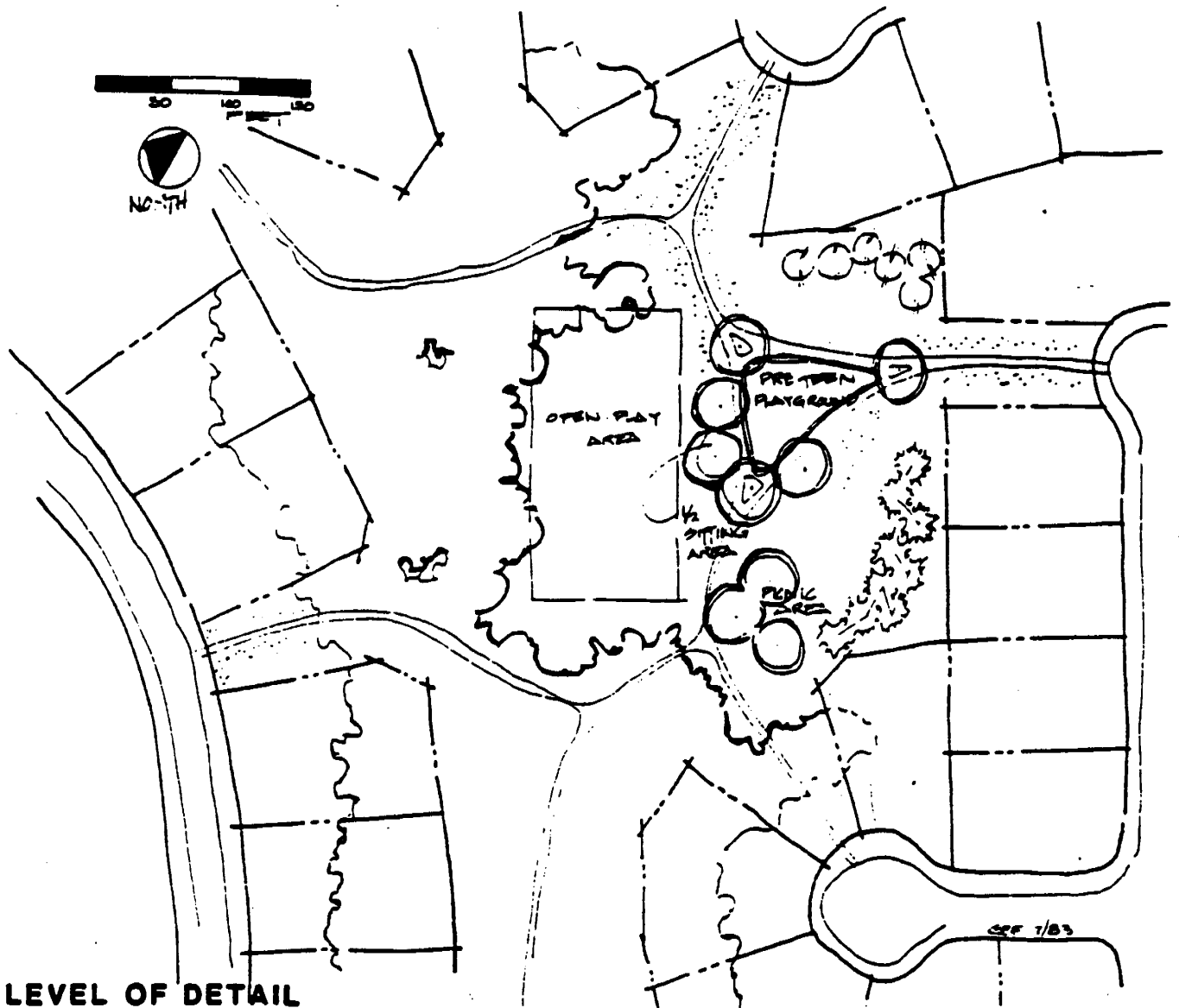

**LEVEL OF DETAIL
PRELIMINARY/COMPREHENSIVE DESIGN PLAN**

ILLUSTRATION # 2.1

Site Plan/Specific Design Plan (CDZ III)

The site plan and specific design plan drawing are the same and are to have all the necessary specifications and details to construct the recreational facilities indicated on the plan. Specific design and construction requirements for each type of facility are in the following chapters. Approved site plans and specific design plans will be used to write the Recreational Facilities Agreement, set the bond amount, construct the facilities, and inspect the construction. Before submitting a site plan for review, all drawings should be carefully checked for completeness, a typical check list follows:

Site Plan Checklist:

- Orientation of facility
- Equipment list
- General notes
- Percent (%) of slope on courts and paths
- Positive drainage around all facilities
- Spot elevations
- Written specifications
- Trees, sizes, species
- Planting detail
- Equipment orientation
- Equipment safety
- Construction details and profiles

An illustration of the typical level of detail of a Site/Specific Design Plan plan appears on the following page.

EQUIPMENT SUBSTITUTIONS

All site plans which have equipment lists shall contain the following note:
"All substitutions of equipment are to have prior approval from the Department of Parks and Recreation".

As of January 1, 1985, the Department of Parks and Recreation has initiated a new procedure for equipment substitutions. The goal is to establish a list of "equals" from which substitutions can be made, and reducing the amount of time required to review these requests.

This listing of equals will be established and updated as requests are made for substitutions.

A standard equipment substitution request form will be used to request an equipment substitution. The form should be completed for each piece of equipment under evaluation. The request will then be approved or disapproved based on the information provided by the applicant.

Once a substitution has been approved, approval will remain in effect as long as the piece of equipment is available, if it is so noted on the form. Otherwise, the equipment substitution is approved on a one time basis.

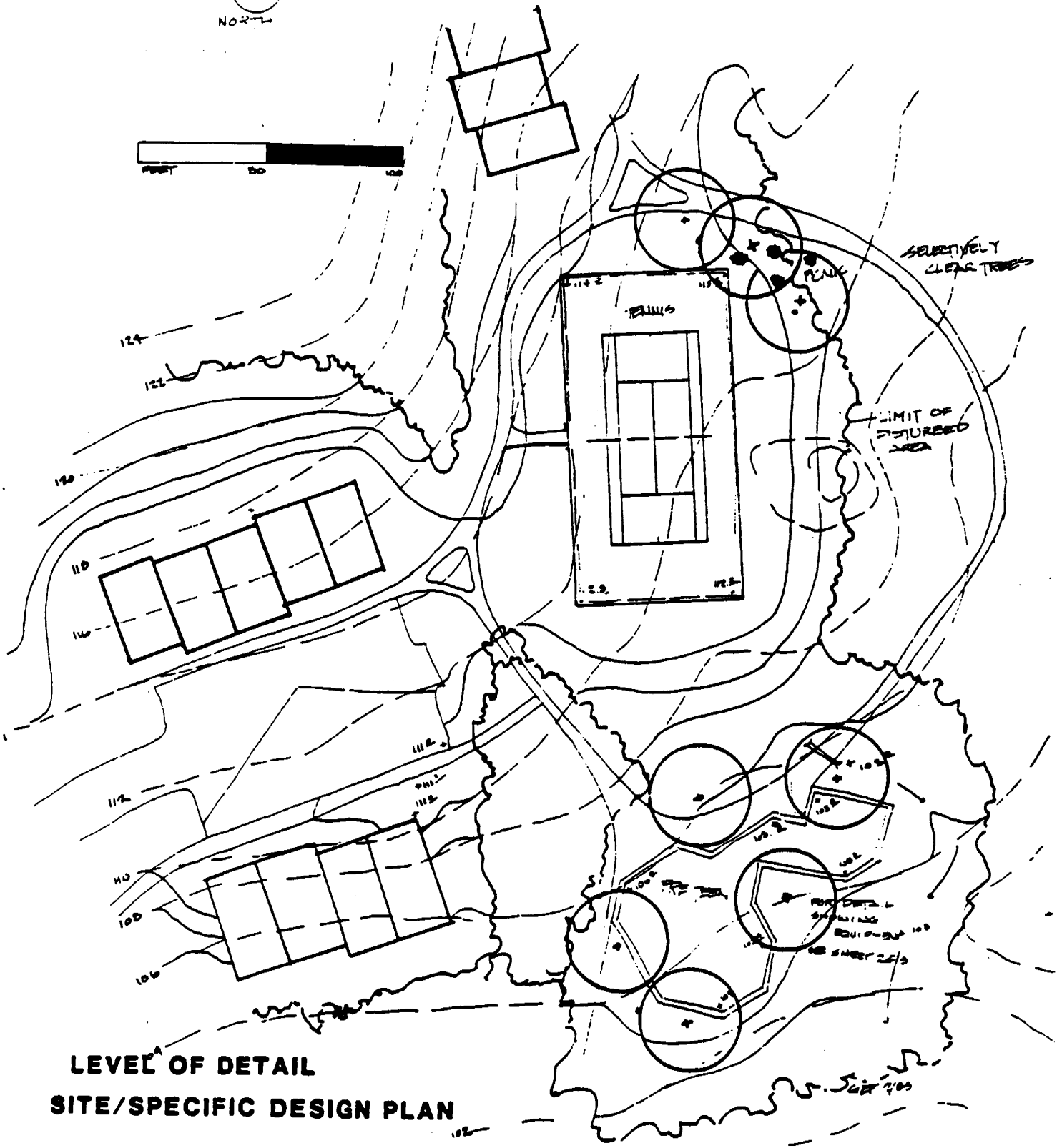

**LEVEL OF DETAIL
SITE/SPECIFIC DESIGN PLAN**

Equipment Substitution Request

PROJECT NAME: -----

Section or Phase: ----- RFA: L.----- F.-----

Applicant: -----

Address of Applicant: -----

Previously Specified Item: Catalog No. -----

Name of Item -----

Manufacturer -----

Substitution Requested: Catalog No. -----

Name -----

Manufacturer -----

Reason for Request:

Previously approved Substitution

Specified Item Discontinued

Substitution is Equal or Better

{ In space below, justify the substitution by comparing pertinent factors of product durability to prove equality, i.e. wood treatment, wood type, finishing connecting system, detailing, etc. Attach pertinent drawings, pictures or specifications for both originally specified item and proposed substitution.

OFFICE USE ONLY:

Disapproved: Application incomplete or Inaccurate Substitution n

Approved: This substitution will be added to the listing maintained by the M-NCPPC Department of Parks and Recreation as equal use in private recreation facilities construction.

Name:

Date:

RECREATIONAL FACILITIES AGREEMENTS

A Recreational Facilities Agreement (RFA) is a requirement of the Subdivision Regulations of Prince George's County, Maryland, in Section 24-135. The RFA is a condition of preliminary plat and site plan approval.

The intent of the RFA is to guarantee that the conditions of approval placed on a preliminary plat or site plan for the provision of parks, recreational facilities and open space for a particular property are met.

The RFA is recorded and made a permanent part of the Land Records to be accessible to any future landowners in the subdivision, or other interested parties. The RFA was established as an enforcement "tool" to be used if needed during the construction of a subdivision.

The sample RFA is a general model and can be modified as necessary to fit the particular subdivision. The bracketed area of the sample agreement is often changed and should be written to suit a particular property; i.e., cluster, Comprehensive Design Zone, town house, recreational community development, etc.

PROCEDURE FOR PROCESSING AN RFA:

1. The applicant or his representative must submit an executed original RFA to the Department of Planning, Development Review Division, three (3) weeks prior to the submission of final plats to the Land Development Division.
2. Upon submission, the RFA will be reviewed. If the agreement is complete, a contract routing slip will be attached, and a contract number assigned. The contract (RFA) will be sent to the Commission's Legal Department for review and approval. It will be forwarded to the Finance Department for review and execution by the Executive Director within three weeks.
3. The executed agreement will then be returned to the Department of Planning, where the Division will notify the applicant or his representative to pick up the agreement and record it at the Prince George's County Courthouse on Main Street in Upper Marlboro, Maryland. The original recorded agreement is to be sent back to the following address:

Maryland-National Capital Park and Planning Commission
Development Review Division
Department of Planning
14741 Governor Oden Bowie Drive
Upper Marlboro, Maryland 20772

The Courthouse will return the recorded RFA to the Department of Planning if the proper notation is made on the back. When received by the Department of Planning, copies will be sent to the developer or his representative and the original sent to the Finance Department.

4. The liber and folio of the RFA is to be placed on all final plats of subdivision prior to submission of the final plats to the Land Development Division. The language to be used is as follows:

This plat subject to a Recreational Facilities
Agreement recorded at Liber _____ folio _____.
5. The RFA will be considered null and void by the Department of Planning at the time all items on the agreement have been constructed and inspected, and bonds or other suitable financial guarantees have been released.

(SAMPLE) RECREATIONAL FACILITIES AGREEMENT

THIS AGREEMENT made this _____ day of _____, 19____, by and between THE MARYLAND-NATIONAL CAPITAL PARK AND PLANNING COMMISSION, a public body corporate, hereinafter referred to as the "Commission" and _____, (hereinafter "Developer").

WHEREAS, the Commission is a public body corporate, created by the State of Maryland and authorized by Article 28, Annotated Code of Maryland, to maintain and operate a park system within the Maryland- Washington Regional and Metropolitan District; and

WHEREAS, the Commission has delegated authority over the operation of parks in Prince George's County to the Prince George's County Planning Board; and

WHEREAS, the Prince George's County Planning Board is charged by Article 66D, Annotated Code of Maryland, with the responsibility and duty to approve subdivision plats for recordation in that portion of the Maryland-Washington Regional District located in Prince George's County; and

WHEREAS, Section 24-135 of the Subdivision Regulations, Prince George's County Code, provides that in conjunction with certain types of development, recreational areas which equal or exceed the requirements for dedication may be provided by a subdivision applicant to satisfy the mandatory dedication requirement of the Prince George's County Subdivision Regulations; and

WHEREAS, _____ is the owner of Parcel _____ as shown on a preliminary subdivision plat entitled _____, said property being the same land as conveyed by _____ to current owner _____ by a certain deed recorded in the Land Records of Prince George's County, Maryland, at Liber _____, folio _____, comprising approximately _____ acres of land, being in the _____ Election District, Prince George's County, Maryland.

NOW, THEREFORE, in consideration of the acceptance by the Prince George's County Planning Board of the Developer's offer to provide private recreational facilities in lieu of mandatory dedication as provided for in Section 24-135 of the Subdivision Regulations for Prince George's County, Maryland, and for other good and valuable consideration, the parties hereto have agreed to the following provisions:

- (1) The Developer shall construct on that portion of its property being subdivided, in accordance with the approved site plan, captioned _____, the recreational facilities approved by the Prince George's County Planning Board, to wit:

(a) (List of Facilities)

- (2) To assure the prompt and satisfactory construction of the facilities set forth in (1) above, the Developer, its successors and/or assigns, shall deliver to the Department of Planning a Performance Bond, or other suitable financial guarantee in an amount to be determined by the Planning Department. Within two (2) weeks prior to the developer's filing for application for building permits, said Developer shall request in writing from the Planning Department a determination as to the amount of the required Performance Bond. Upon the Developer's application for building permits, said Performance Bond shall be delivered to the Department of Planning, The Maryland-National Capital Park and Planning Commission in the County Administration Building, Upper Marlboro, Maryland 20772.
- (3) The Performance Bond shall run to the benefit of the Commission and not be conditional. It is agreed by the parties hereto that the Commission shall use the Performance Bond if it finds that the Developer named herein, has failed to construct the recreational facilities as set forth in (1) above and in accordance with the plans filed with the Department of Planning. The Commission's decision as to the satisfaction of the facilities set forth in (1) above shall be binding on all parties. At such time as the Commission deems the recreational facilities completed and satisfactory, it shall return the Performance Bond.
- (4) This Agreement and Bond shall insure the completion of the facilities set forth herein in phase with development. With each phase of construction, as evidenced by the application for building permits, the Developer shall provide a proportionate share of the amenities as set forth in (1) above. The determination as to the facilities to be provided in accordance with an application for building permits shall be determined as per (2) above. Furthermore, the amount of the Performance Bond shall be proportioned to the phased facilities to be provided. All recreational facilities shall be constructed to Department of Parks and Recreation standards.
- (5) The contractors will not discriminate against any employee or applicant for employment because of age, sex, race, creed, color, national origin or physical handicap. The contractor will take affirmative action to insure that applicants are employed and the employees are treated during employment, without regard to age, sex, race, creed, color, national origin or physical handicap.
- (6) The Contractor shall indemnify and save harmless the Commission from and against all actions, liability, claims, suits, damages, cost or expenses of any kind which may be brought or made against the Commission of which the Commission must pay and incur by reason of or

in any manner resulting from injury, loss or damage to persons or property resulting from his negligent performance of or failure to perform any of his obligations under the terms of this contract or agreement.

- (7) The provisions of this Agreement shall be a covenant which shall run with the land and be binding on the successors and/or assigns of the Developer.
- (8) This Agreement shall be recorded among the Land Records of Prince George's County, no later than two (2) weeks prior to the submission of the above-named plat to the Land Development Division of the Commission, all recording fees to be paid by the Developer. Furthermore, the Developer shall send, by certified mail to the Commission's Legal Department, a copy of this Agreement as recorded. The original recorded Agreement is to be returned to the Department of Planning. The failure on the part of the developer herein to record this Agreement shall preclude the issuance of any building permits that may be applied for in the above-named plat of subdivision.

IN WITNESS WHEREOF, the parties hereto have affixed their respective hands and seals as of the day and year first above written.

THE MARYLAND-NATIONAL CAPITAL
PARK AND PLANNING COMMISSION

Attest:

Secretary-Treasurer

By _____

Executive Director

Attest:

(Current Landowner)

Printed Name and Title

By _____
Printed Name and Title

STATE OF MARYLAND :
COUNTY OF : ss

I hereby certify that before me, the subscriber, a Notary Public in and for the State and County aforesaid, personally appeared _____, Executive Director for The Maryland-National Capital Park and Planning Commission, and acknowledged that he executed the above agreement for the reasons and purposes stated therein.

Witness my hand and official seal this _____ day of _____, 19__.

Notary Public

My commission expires:

AGREEMENT TO AMEND RECREATIONAL FACILITIES AGREEMENT

It is sometimes necessary to amend a Recreational Facilities Agreement (RFA) because of zoning or subdivision changes, action by the Prince George's County Planning Board, marketing changes, clerical error, etc. A sample "agreement to amend" is attached and the procedure to amend is as follows:

1. Meet with the Department of Planning, to outline the reasons for requesting an amendment to the recorded RFA. Tentative wording for the amendment will be worked out jointly at this meeting.
2. Determination will be made as to whether or not the proposed amendment needs to be presented to the Prince George's County Planning Board. An amendment must be done upon reconsideration motion by Planning Board according to Rules of Procedure with regard to grounds and time limitation for making requests. Presentation to the Planning Board is required only where the amendment(s) are substantial changes from the previous preliminary plat or site plan approvals. If presentation to the Planning Board is required, it will be done by the Department of Planning with the applicant in attendance. When Planning Board approval is received, the amended agreement will then be processed.
3. The executed agreement will then be returned to the Planning Department, where the Department will notify the applicant or his representative to pick up the agreement and record it at the Prince George's County Courthouse on Main Street in Upper Marlboro, Maryland. The original recorded agreement is to be sent back to the following:

Maryland-National Capital Park & Planning Commission
Department of Planning Development Review Division
14741 Governor Oden Bowie Drive
Upper Marlboro, Maryland 20772

The Courthouse will mail it to the Planning Department if the proper notation is made on the back of the RFA. When received by the Planning Department, copies will be sent to the developer and/or his representative and the original sent to the Finance Department.

4. The liber and folio of the RFA is to be placed on all final plats of subdivision prior to submission of the final plats to the Land Development Division. The language to be used is as follows:

This plat subject to a Amended Recreation Facilities Agreement recorded in Liber _____ folio _____.
5. The RFA will be considered null and void by the Department of Planning at the time all items on the agreement have been constructed and inspected, and bonds or other suitable financial guarantees have been released.

SAMPLE AGREEMENT TO AMEND

THIS AGREEMENT TO AMEND made this _____ day of _____ 198____, by and between THE MARYLAND-NATIONAL CAPITAL PARK AND PLANNING COMMISSION, a public body corporate, hereinafter referred to as the "Commission", and name of _____ landowner a Maryland corporation hereinafter referred to as the "Developer."

WHEREAS, the Developer and the Commission, parties hereto, entered into a Recreational Facilities Agreement dated _____, recorded at Liber _____, folio _____, for the purpose of _____, located in the _____ Election District of Prince George's County, Maryland, from the Developer to the Commission for park and recreational purposes; and

WHEREAS, within the intervening time since the execution of the said Recreational Facilities Agreement dated _____, the Developer and the Commission agree that _____

_____ ; and

WHEREAS, the Subject Property is part of the _____ pursuant to the said Recreational Facilities Agreement dated _____; and

WHEREAS, the Commission has stated the reason(s) why it is necessary to amend; and

WHEREAS, the Developer and the Commission, parties hereto, have agreed to so amend the said Recreational Facilities Agreement dated _____, by the execution of this Agreement to Amend;

NOW, THEREFORE, THIS AGREEMENT WITNESSETH, the said parties hereto, their successors and/or assigns, in consideration of the premises aforesaid and for other good and valuable consideration, do hereby agree as follows:

1. That notwithstanding anything to the contrary in this Agreement to Amend, the terms and conditions of the said Recreational Facilities Agreement dated _____, remain in full force and effect as to the _____ of real property that have been or will be dedicated to the Commission for park and recreational purposes.

2. That this Agreement to Amend shall be recorded among the Land Records of Prince George's County, said recording fees to be paid by the Developer, his successors and assigns.

IN WITNESS WHEREOF, the parties hereto have caused these presents to be executed on the date first hereinabove written.

ATTEST:

THE MARYLAND-NATIONAL CAPITAL PARK AND PLANNING COMMISSION

Secretary-Treasurer

Executive Director

AGREEMENT TO AMEND

ATTEST: _____

(Secretary)

BY: _____
(Vice President)

STATE OF MARYLAND
COUNTY OF _____: ss.

On this ___ day of _____, 198__, before me, the undersigned officer, personally appeared _____ who acknowledged himself to be the Executive Director of THE MARYLAND-NATIONAL CAPITAL PARK AND PLANNING COMMISSION, and that he, as such, being authorized so to do, executed the foregoing instrument for the purposes therein contained.

In witness whereof, I hereunto set my hand and official seal.

Notary Public, Maryland

My commission expires:

STATE OF MARYLAND)
) : ss
COUNTY OF _____)

On this ___ day of _____, 198__, before me, the undersigned officer, personally appeared _____, who acknowledged himself to be the _____, and that he, as such, being authorized so to do, executed the foregoing instrument for the purposes therein contained.

In witness whereof, I hereunto set my hand and official seal.

Notary Public, Maryland

My commission expires:

AGREEMENT TO RESCIND RECREATION FACILITIES AGREEMENT

An agreement to rescind is required when a preliminary plat of subdivision has been approved that is substantially different from the previously recorded plat for that property. The agreement to rescind must be recorded prior to submission of new final plats.

Procedure to amend follows:

1. Submit preliminary plat of subdivision to the Land Development Division and obtain preliminary plat approval from the Prince George's County Planning Board.
2. Set up meeting with the Department of Planning to discuss rescinding previously recorded recreational facilities agreement. (Preliminary Plat approval may have already covered these points).
3. Prepare and execute agreement to rescind.
4. Upon submission, the RFA will be reviewed by the Department of Planning. If the agreement is complete, a contract routing slip will be attached, and a contract number assigned. The contract (RFA) will then be sent to the Commission's Legal Department for review and approval. It will be forwarded to the Legal Department for review and approval. It will be forwarded to the Finance Department for review and execution by the Executive Director.
5. The executed agreement will then be returned to DPR, where the Department will notify the applicant or his representative to pick up the agreement and record it at the Prince George's County Courthouse on Main Street in Upper Marlboro, Maryland. The original recorded agreement is to be sent back to the following:

The Maryland-National Capital Park & Planning Commission
The Department of Planning
14741 Governor Oden Bowie Drive
Upper Marlboro, Maryland 20772

The Courthouse will mail it to the Department of Planning if the proper notation is made on the back of the RFA. When received by DPR, copies will be sent to the developer and/or his representative and the original sent to the Finance Department.

6. The liber and folio of the RFA is to be placed on all final plats of subdivision prior to submission of the final plats to the Land Development Division. The language to be used is as follows:

This plat subject to a Rescinded Recreation Facilities Agreement recorded in Liber _____ folio _____.

7. The RFA will be considered null and void by the Department of Planning at the time all items on the agreement have been constructed and inspected, and bonds or other suitable financial guarantees have been released.

AGREEMENT TO RESCIND

THIS AGREEMENT TO RESCIND made this _____ day of _____, 198____, by and between THE MARYLAND-NATIONAL CAPITAL PARK AND PLANNING COMMISSION, a public body corporate, hereinafter referred to as the "Commission", and _____, hereinafter referred to as the "Developer".

WHEREAS, the Commission and _____, parties hereto, entered into a Recreational Facilities Agreement dated _____, recorded at Liber _____, folio _____, for the purpose of providing recreational facilities in lieu of land to satisfy the mandatory dedication requirements of the Subdivision Regulations of Prince George's County, Maryland, for the property recorded among the Land Records of Prince George's County, Maryland, in Liber _____, folio _____ comprising _____ + acres of land, being in part as shown on a plat of subdivision entitled, _____ (plat name), recorded in Plat Book _____ at Plat _____, said _____ (describe recreational facilities agreement)

_____, being part of the lands conveyed to _____ by deed dated _____, and recorded among the Land Records of Prince George's County, Maryland, in Liber _____, folio _____, comprising _____ + acres of land, all reference made, being to the Land Records of Prince George's County, Maryland, and shown on a plat entitled _____, located in the Election District of Prince George's County, Maryland; and

WHEREAS, within the intervening time since the execution of the said Recreational Facilities Agreement dated _____, The Developer and the Commission agree that an unforeseen problem has arisen as a result of a _____ thus making it unfeasible for the current Developer to follow the original recorded Recreational Facilities Agreement; and

WHEREAS, the current Developer and the Commission, the parties hereto have agreed to so rescind and render null and void the said Agreement dated _____, by the execution of this Agreement to Rescind.

NOW, THEREFORE, THIS AGREEMENT WITNESSETH, the said parties hereto, their successors and/or assigns, in consideration of the premises aforesaid and for other good and valuable consideration, do hereby agree as follows:

1. That a previous Agreement executed by and between the parties hereto and dated _____, and recorded at Liber _____, folio _____, in the Prince George's County Land Records, hereby is deemed rescinded and is rendered null and void and of no force and effect.
2. That the Agreement to Rescind shall be recorded among the Land Records of Prince George's County, said recording fees to be paid by the current Developer, his successors or assigns.

IN WITNESS WHEREOF, the parties hereto have caused these presents to be executed on the date first hereinabove written.

ATTEST:

THE MARYLAND-NATIONAL CAPITAL PARK AND PLANNING COMMISSION

Secretary-Treasurer

By: _____
Executive Director

ATTEST:

Current Landowner

By: _____

STATE OF MARYLAND)
 : ss
COUNTY OF)

On this _____ day of _____, 198 , before me, the undersigned officer, personally appeared _____, who acknowledged himself to be the Executive Director of THE MARYLAND-NATIONAL CAPITAL PARK AND PLANNING COMMISSION, and that he, as such, being authorized so to do, executed the foregoing instrument for the purpose therein contained.

In witness whereof, I hereunto set my hand and official seal.

Notary Public

My Commission Expires:

STATE OF MARYLAND)
 : ss
COUNTY OF)

On this _____ day of _____, 198 , before me, the undersigned officer, personally appeared _____, who acknowledged himself to be the President of _____, and that he, as such, being authorized so to do, executed the foregoing instrument for the purposes therein contained.

In witness whereof, I hereunto set my hand and official seal.

Notary Public

My Commission Expires:

PERFORMANCE BONDS OR OTHER SUITABLE FINANCIAL GUARANTEES

Performance bonds or other suitable financial guarantees (Bonds) are required as a condition of preliminary plat approval, site plan approval, and/or a recreational facilities agreement. The bonding process requires approximately three (3) weeks, depending on the type of bond being processed.

The following types of bonds are acceptable to The Maryland-National Capital Park and Planning Commission:

1. Surety Bonds (Performance Bonds) This type of bond is essentially a kind of insurance in the form of a bond payable to the M-NCPPC. The subdivider pays a bonding company a premium to guarantee the funds necessary to complete the improvements. In case of default by the developer, the specified amount for the bond goes to the M-NCPPC needed to complete the facilities. When improvements are completed to the satisfaction of the M-NCPPC, the bond will be returned to the subdivider.
2. Escrow Account The subdivider deposits either cash, a note, a bond, or some instrument readily convertible into cash (for a specific face value) with a bank in an account payable to the M-NCPPC. If the subdivider fails to complete the improvements within the specified time limits, or as extended by the M-NCPPC the bank turns over the account to the M-NCPPC. When the improvements are completed in a manner satisfactory to the M-NCPPC, the bank is notified to release the funds back to the subdivider.
3. Letter of Credit The subdivider secures a letter of credit from a bank or other institution with resources sufficient to cover the cost of improvements. The letter pledges the creditor will pay the cost of improvements in case of default by the subdivider. The credit may not be revoked without the M-NCPPC approval. Upon successful completion of the improvements, the M-NCPPC will notify the bank or lending institution to release the subdivider from the obligation.

PROCEDURE FOR PROCESSING

1. Write the Department of Planning, requesting a bond amount be set for a project. Enclose a print of the site development plan with the construction area delineated.
2. The Planning Department will conduct a cost analysis to set a bond amount. A letter will then be sent to the developer stating the bond amount for presentation to the bank or lending institution, if necessary.

Note: The escrow agreement is treated like a contract and requires approximately three (3) weeks to process. Suitable examples of bonds appear on the following pages.

The following must be on the bond:

- A. Bond number in upper right-hand corner;
 - B. Name of bonding company and State in which incorporated;
 - C. Date executed by bonding company;
 - D. Signature of Officer of corporation named as principal, witness as to that signature and corporation impression seal;
 - E. Attorney signing on behalf of bonding company signature; witness as to that signature and corporation impression seal;
 - F. Agency address of bonding company;
 - G. Bond must be countersigned by a Maryland Resident Agent, putting address and Maryland license number thereon. (Note: If Attorney-In-Fact is registered in Maryland, he/she must execute both sections)
 - H. Updated Power of Attorney;
 - I. Completion of Acknowledgment Form:
 - A. Corporate: To be executed by secretary of corporation, affixing impression seal and listing all officers with their respective titles;
 - B. Co-Partnership/Venture: Signature of principal must be notarized and list all partners or trustees;
 - J. If bonding company lists individuals as co-principals, each person must sign and have witnessed;
 - K. Bond amount;
 - L. Lot & block numbers of houses that bond covers if applicable;
 - M. Liber and folio of recorded Recreation Facilities Agreement;
 - N. List of facilities covered by bond;
 - O. Statement of unconditional payment to favor to M-NCPPC in case of default;
 - P. Return all copies of bond. Upon approval by the M-NCPPC, appropriate copies will be sent to the principal and bonding company.
4. Bond is to be delivered to The Maryland-National Capital Park and Planning Commission, Department of Planning, 14741 Governor Oden Bowie Drive, Upper Marlboro, Maryland 20772.
 5. Following approval of the Bond or other suitable financial guarantee, by the Legal Department and Department of Planning, the Department of Planning will release all building permits covered by that bond.

ESCROW AGREEMENT

THIS ESCROW AGREEMENT is made this _____ day of _____, 19____, by and between THE MARYLAND-NATIONAL CAPITAL PARK AND PLANNING COMMISSION (hereinafter referred to as the Obligee), _____, (hereinafter referred to as the Obligor), and A. Edward Navarre, Secretary-Treasurer of The Maryland-National Capital Park and Planning Commission (hereinafter referred to as the escrow agent).

NOW THEREFORE, in consideration of the monies to be paid by the Obligor, and other good and valuable consideration, the parties hereto agree as follows:

1. The Obligor and Obligee do hereby appoint and designate the above-named escrow agent for the purposes as hereinafter set forth.

2. The Obligor does hereby deposit with the escrow agent a _____ in the amount of _____ Dollars (\$ _____), payable to The Maryland-National Capital Park and Planning Commission, which is to be held by him for use in accordance with the terms and provisions of this Agreement.

3. The Obligor and Obligee do hereby authorize the escrow agent to keep and preserve the money in his possession to secure the satisfactory construction of _____ list facilities

_____ in accordance with the Recreational Facilities Agreement for the _____ name of _____ subdivision, recorded at Liber _____, folio _____, among the Land Records of Prince George's County, Maryland.

4. Upon either (1) the satisfactory construction of the items listed above, or (2) the submission to the Obligee of a Performance Bond or other proven financial instrument in the amount of _____ securing the satisfactory construction of the same items as listed in three (3), this agreement becomes null and void.

5. By deposit of this money with the escrow agent, The Maryland-National Capital Park and Planning Commission agrees to waive the requirement for a Performance Bond.

6. The Obligor and Obligee do hereby release the escrow agent from, and agree to indemnify him against, any liability whatsoever arising out of this Agreement.

7. Any interest earned on the principal sum is the property of the obligor.

Executive Director
The Maryland National Capital
Park and Planning Commission

Subdivider: _____ Name:
Title:

Secretary-Treasurer
The Maryland-National Capital
Park and Planning Commission

Witness to Subdivider

IRREVOCABLE LETTER OF CREDIT
MARYLAND NATIONAL CAPITAL PARK
AND PLANNING COMMISSION

Maryland-National Capital Park
and Planning Commission
6600 Kenilworth Avenue
Riverdale, Maryland 20737

Date _____
Re: Irrevocable Letter of Credit No. _____
Subdivision: _____

Gentlemen:

We hereby authorize you to draw on the _____
_____, for the account of _____
_____, in the sum of _____
(\$ _____)

by your sight drafts, accompanied by your signed statement that construction of recreational facilities pursuant to an Agreement dated _____, 19__ and recorded in Liber ____, folio ____, is still outstanding and the work remains uncompleted.

This Letter of Credit will expire one (1) year from this date, however, it is a condition of this Letter of Credit that it shall be automatically extended without amendment on a year-by-year basis from the expiration date of the initial year and any subsequent year's extension, unless thirty (30) days prior to any such yearly date we shall notify you through The Maryland-National Capital Park and Planning Commission, by registered letter that we elect not to consider this Letter of Credit renewed for an additional one (1) year. Upon receipt by The Maryland-National Capital Park and Planning Commission, of written notice from us by registered mail that we elect not to consider this Letter of Credit renewed for an additional one (1) year, the Commission may issue its sight draft on us for the full amount of the Letter of Credit provided only that construction of the facilities is still outstanding and the work has not been totally completed. Payment on such sight draft shall be made within thirty (30) days of such notice not to renew the Letter of Credit.

Upon any default by _____, as determined by The Maryland-National Capital Park and Planning Commission, The Maryland-National Capital Park and Planning Commission may issue its sight draft as provided herein without having incurred any liability to complete the work authorized by such permit, by means of such sight draft accompanied by your statement that the aforesaid permit is still outstanding and the work authorized thereby remains uncompleted. Payment on such sight drafts shall be made within thirty (30) days of the issuance of the sight draft. After such time, interest shall accrue on the principal in the amount of _____ percent () per annum, payable by _____. If litigation is necessary to collect on

this letter, then the bank shall be responsible for all additional costs to The Maryland-National Capital Park and Planning Commission, including _____ Dollars (\$) per hour for each hour devoted thereto by the staff of The Maryland-National Capital Park and Planning Commission General Counsel's Office.

It is understood that this Irrevocable Letter of Credit is a conditional precedent to the issuance of Building Permits.

We hereby agree with you that all drafts drawn under and in compliance with the terms of this Letter of Credit will be honored on delivery of documents as specified.

Name of Development Company joins herein for the purpose of acknowledging that it will be bound by the terms herein.

ATTEST:

Very truly yours,

(Name of Bank)

BY: _____ (SEAL)

TITLE _____

(Name of Permittee)

BY: _____ (SEAL)
Vice President

TITLE _____

The Maryland-National Capital Park and Planning Commission

BY: _____ (SEAL)

ACKNOWLEDGEMENT

State of _____ (Bank or Holding Institution)

County of _____, ss:

On this _____ day of _____, 19____, before me personally appeared _____, known to me to be of the firm of _____, described in and who executed the foregoing instrument and he thereupon acknowledged to me that he executed the same as and for the act and deed of said firm.

NOTARY PUBLIC

My Commission expires _____

PAYMENT OF FEE-IN-LIEU

Payment of fee-in-lieu to be made at final plat. The payment is to be made to M-NCPPC, the check to be certified in the amount of 5% of the assessed property value. The check with final plat is to be given to the Land Development Division of M-NCPPC in the County Administration Building.

SITE INSPECTIONS

Periodic announced and unannounced site inspections will be made to sites where recreational facilities are being constructed. A final site inspection will be made by the Department of Planning at the request of the developer for release of bonds and agreements. The Department of Parks and Recreation will also make periodic checks of property that has been dedicated, or is to be dedicated, to M-NCPPC.

At the time of the final inspection, a punch list will be drawn up and sent by letter to the developer. An appropriate length of time, generally 30 days, will be given for completion of the punch list.

VIOLATIONS

If the developer does not complete the recreational facilities or site work in a reasonable amount of time (or as extended), the matter will be turned over the Associate General Counsel's office for collection.

GENERAL RECREATION DESIGN

Parks recreation and open space systems have developed over the years into categories of recreation spaces that start with the "vest-pocket park", which is close to home and end with the national park or regional wilderness that preserves spectacles of nature in a manner in which we all can see and use them. The suppliers of the parks, recreation and open spaces are now as diversified as the systems being provided. Builder/developers, private conservation foundations, local, state and federal governments are all now in the business of providing parks, recreation and open spaces. It is extremely important that we begin to think in terms opportunities and not just in terms of acreages.

The Department of Parks and Recreation (DPR) has recognized a need to assist the builder/developer in defining the appropriate levels of recreation that should be provided "close-to-home". More importantly the DPR recognizes that the builder/developer and their designers are a creative force that must not be stifled but rather provided with basic recreational information. This information will be the basis on which decisions can be made to provide a sufficient variety of recreational opportunities to the perspective residents of a subdivision. Frequently recreational facilities are spoken of in quantitative terms and not qualitative terms, in order to change this it is necessary for the private sector and local government to work affectively as a team.

Planning for a variety of recreational opportunities begins at the same time the planning starts for a new housing development. As designers, builders/developers we know the general sizes required to provide streets, parking lots and building footprints for housing and we are also aware of the need and general requirements for setbacks to provide for the safety and enjoyment of future residents.

The same considerations apply to recreation, the shape of a recreational space is just as important as its size. Certain activities football, basketball, playground are best suited for defined areas such as rectangles, squares, or circles, there are others that are linear in nature such as walking, running, riding, hiking, etc., which require less structured spaces. Once armed with the knowledge and the tremendous variety of recreation opportunities, their shapes, sizes and siting requirements, it becomes much easier to understand the potential within a housing community to provide a balance of recreational opportunities, and still maintain the level of housing units.

PLANNING PROCESS

Park, recreation and open spaces are to be considered a land use in the first phase of the planning process. Before we determine just what type of house goes where we determine general relationships between houses, roads and parking; and what areas are best suited for these uses based on a site analysis. Recreation is best planned for when it is considered as a land use in the initial phase as opposed to "fitting things in" to meet requirements at the last minute. Problems stem from this type of last minute thinking from the preliminary plan forward to the actual construction, and occupancy of new residents.

The size and quantity of the areas to be used for recreation will depend on the size of the planned housing development. Obviously projects of 50 or 100 units would have a lot different needs than projects of 250 or 500 units. No matter how large or small a development a central recreation area suitable for

intense active recreation should be provided. The central recreation areas can then be connected through a series of paths and open spaces to satellite active and passive recreation areas and/or link to the public or other private systems.

The process of determining the recreational needs of future residents, takes time. Some developers of larger projects utilize marketing studies to ascertain a buyer profile, others provide a wide range of activities for the young as well as old.

TYPICAL LAND USE PLAN FOR PARKS, RECREATION FACILITIES, AND OPEN SPACE

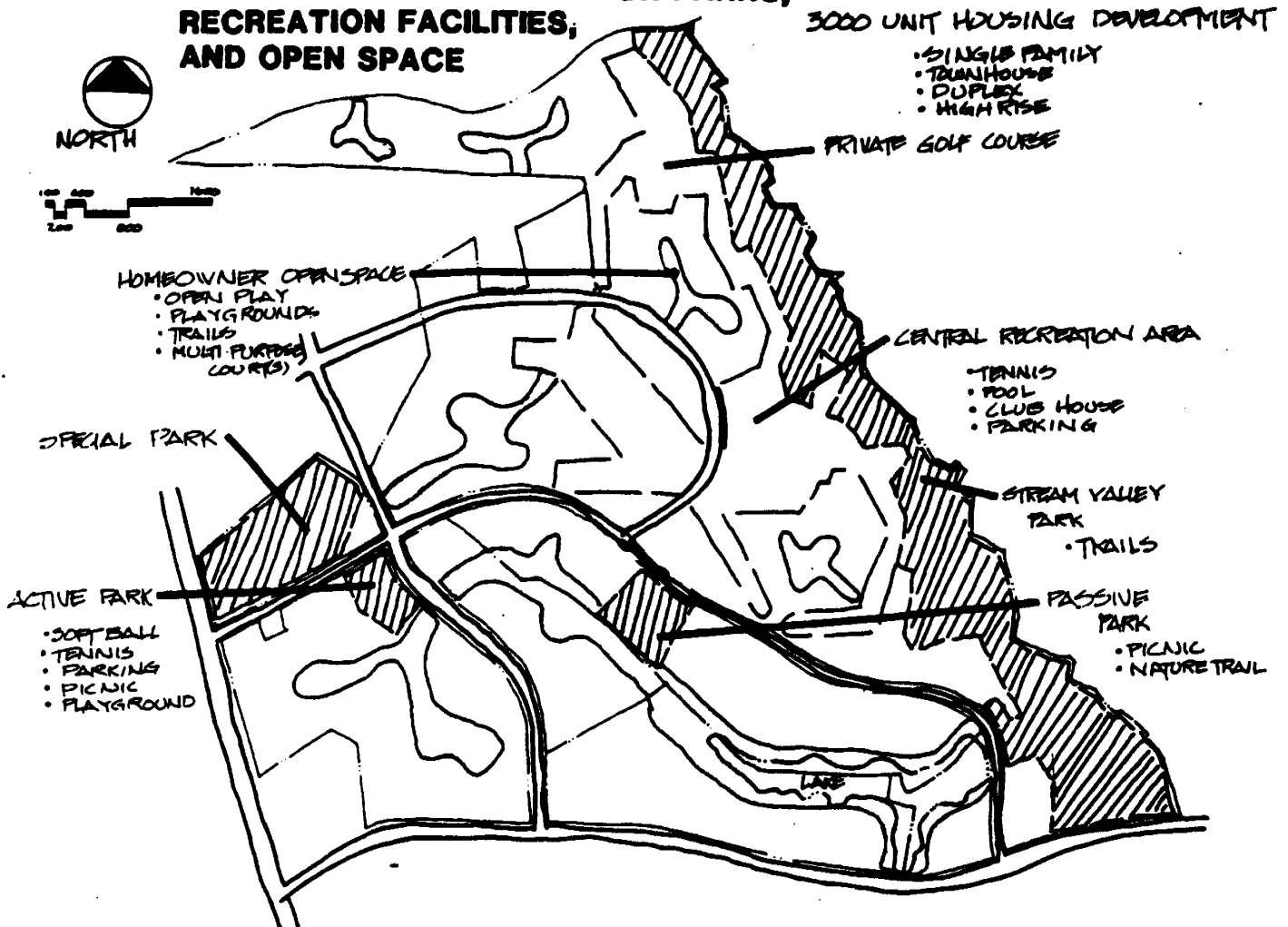
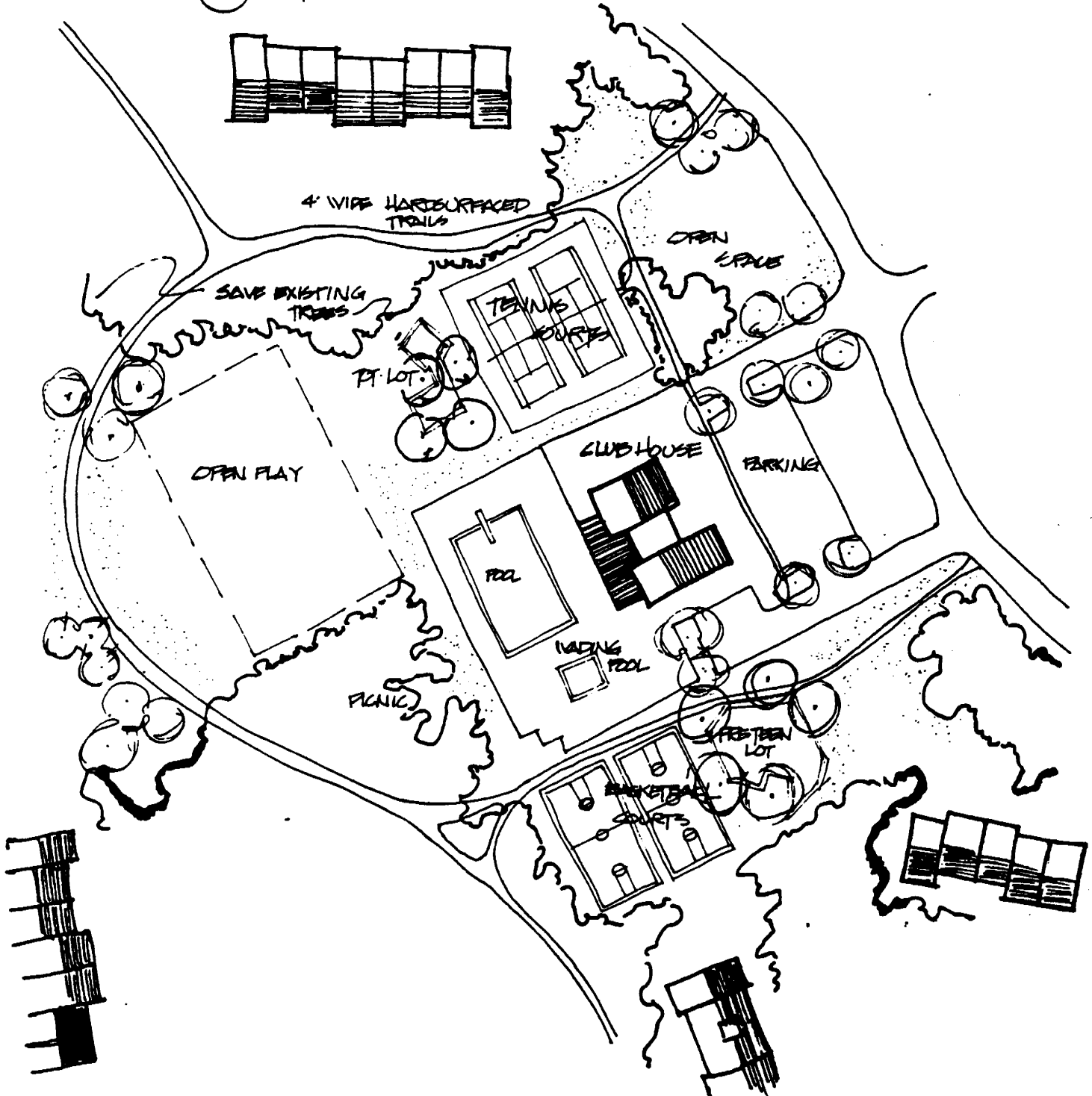

ILLUSTRATION # 3.1

CENTRAL RECREATION AREAS

Utilization of a central recreation area in a housing development can provide a sense of community identity, as well as, a place for needed socialization. Some of the more successful developments have a central recreation area(s), although traditionally the central area was a swimming pool and bath house, or some other major facility (club house or tennis courts). They can be anything. The size and location of the central area(s) are determined by the number of units and projected population.

NORTH SCALE 1"=100'



TYPICAL CENTRAL RECREATION AREA

Recreation areas can range from 1/4 acre to 10 acres depending on the type of facilities that might eventually be sited. The central area can be located on a prominence with a view or vista of the project or the surrounding area, the confluence of major subdivision streets or an area that is readily accessible to residents by either foot or car. If by car the area needs to supply ample parking to avoid conflicts between recreational area users and residents.

Satellite

A satellite recreation area in a major project may be a central recreation area in a minor project. A hierarchy of open spaces, parks and recreation is being provided in a housing development just as a hierarchy of recreation is being provided with the various park systems. Satellite areas may range in size from 1/4 acre to whatever size is needed.

Open Space Links

The spaces that link the satellite and central recreation areas should vary in length and width to provide a variety of experiences to the walker, jogger, runner or bicyclist. The designer should avoid spaces that became alleys, drainage ditches or maintenance headaches.

Parking

Sufficient parking should be provided at major recreation areas in accordance with Section 31 of the Prince George's Code under the heading of Parking and Loading.

Maintenance

Proper design and grading to insure positive drainage is important to decrease the long range maintenance of any recreation areas regardless of its ownership. The initial costs of construction are far less than the term maintenance.

Landscaping

Refer to the section of manual on Landscaping.

Flood Plain:

Utilization of the 100 year flood plain is acceptable with the exception of obstructions i.e., playgrounds, fences, backstops which are to be outside of the 100 year floodplain. Use of the floodplain is discussed for each facility contained in this manual.

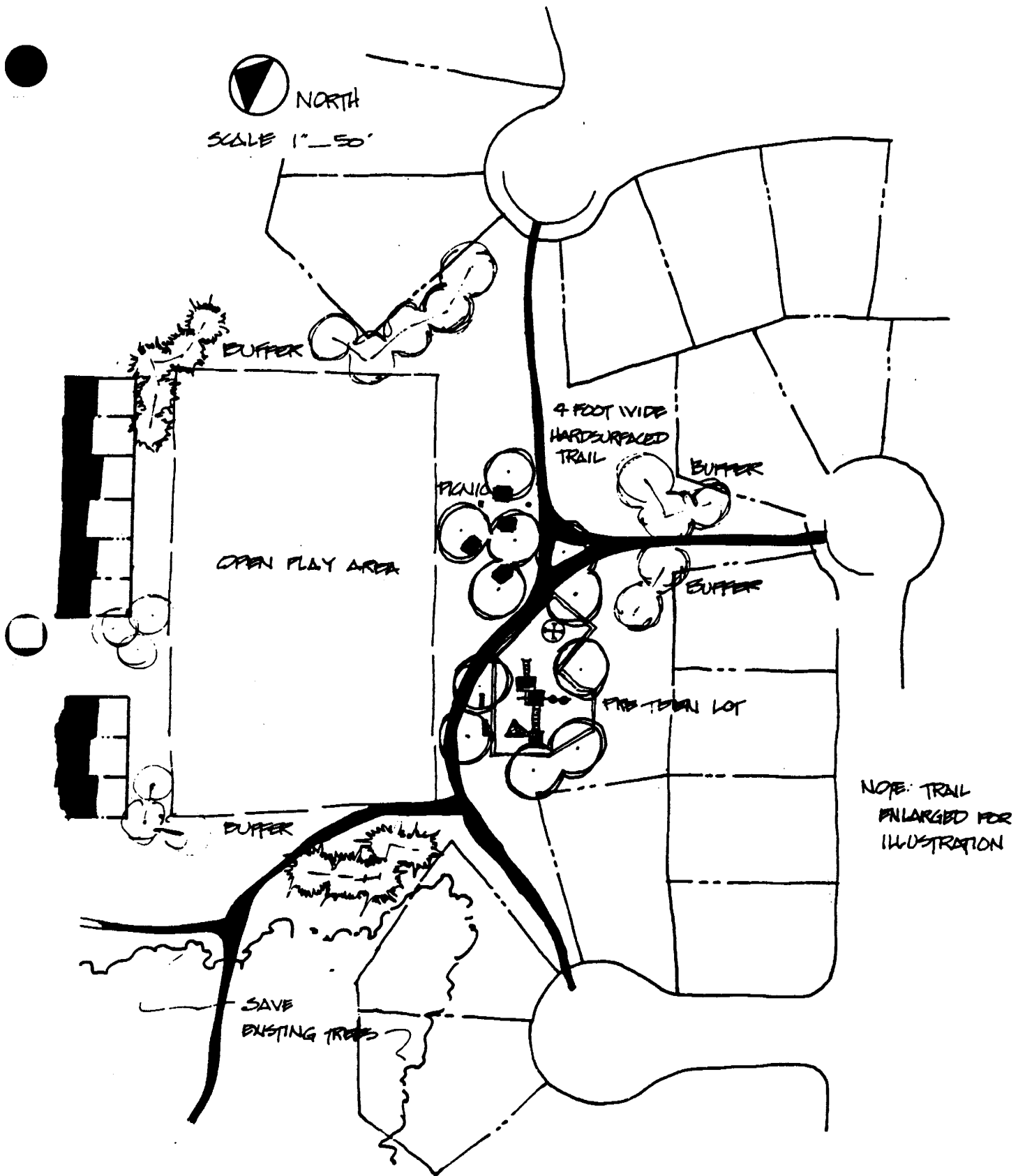

NOTE: TRAIL
ENLARGED FOR
ILLUSTRATION

TYPICAL DEVELOPED SATELLITE OPEN SPACE

PLAYGROUNDS

A child's "work" is play to adults. Play is an integral and extremely complex part of a child's physical, mental and social growth. Traditionally, playgrounds have provided only for the physical growth of a child, and have not recognized the need to provide for the mental and/or social growth of the user. A properly designed, fun, attractive and stimulating playground is as much of a challenge to the children who will use it as to the designer who designs it.

The increased awareness of the importance of early childhood behavior and growth and its direct relationship to adulthood, has led to a rethinking of play in general and playgrounds specifically. A child does half his learning before he is four years old. 30% before he reaches eight years of age and 20% during the remaining years of elementary and secondary education. During these growth years a child spends as much time at play (in or out of playgrounds) as in a classroom.

Children respond directly to an enriched environment, by developing their awareness and capabilities at a geometric rate. Psychologists now consider environment to be a major factor in learning as it balances out the heredity aspects of intelligence. Three major categories have emerged that will provide an enriched environment for play in a playground, these are physical, social and cognitive.

Physical play is the development of motor skills, traditionally playgrounds have provided ample opportunities for physical growth. A varying progression of activities are to be provided to challenge a child to reach, climb, jump, slide as far as he/she dares; children rarely over extend themselves and cause injury. As adults we have developed our fears and cautions more than a child and transfer them to children. Care must be taken in the selection of equipment to assure that the size of bars and heights are appropriate for a particular age group. This is emphasized by noting the sizes of hands in illustration #4.1 on page 41. A 3" diameter pipe would hardly be fitting in a tot lot, 6" is a "climb" to a one and a half year old, but a progressive order where achievement and accomplishment can be felt would be worthwhile.

Social play is more abstract in nature but is easily recognizable when thought of in terms of cooperation between children, interaction between children and between children and their environment and finally role playing. Cooperation is provided by selecting equipment where a group of children would have to share their strengths and "work" together to get the whirl to go faster, to swing higher. One needs a push to get a tire swing to go in one direction, interaction not only occurs when a child interacts with his environment but also when he relates to another child. Interaction is encouraged by the use of various size and shapes of enclosures that range from a small area for two or three to a large area that will encourage sharing by many. Role playing is that time when a log becomes a airplane, a horse or a ship and a child is the pilot, cowboy or captain. This is a time of testing one's personality and making conquests of "unknown worlds". Although preformed play equipment is "neat looking" i.e., space ships, horse, bugs, it stifles the imagination and limits the range of roles.

Cognitive play is the third major type of activity that takes place in a playground, it is the awareness of one's surroundings and problem solving. A well designed playground provides a variety of options to the user, allowing a

of ones capabilities and solutions in a controlled environment i.e., to go from one end to the playground to another one can either climb steps or "shinny up" a pole to a platform then either swing across or walk over hand over hand to a platform or series of platforms which allow the user to go up or down into a whole new set of adventures. By giving the user choices, you are giving him decisions to be made and an environment to manipulate.

Playgrounds are three dimensional solids, each child or each playground should have the opportunity to explore ins and outs, ups and downs, and have places to observe others at play that are both hidden and obvious. Equipment in a playground should be linked, this means literally putting them together by overlapping platforms, stepping columns etc. The designer must think of a playground as an adventure where swinging, climbing, bouncing and observing are all one big adventure and not four separate activities.

Playgrounds are generally designed for 2 age groups; the pre-schoolers or tots from 6 months to 5 years and the pre-teens ages 5 to 12. These 2 groups have different capabilities. The older pre-teens have more highly developed motor skills and a greater need to burn energy than do the pre-schoolers.

It is the joint responsibility of the designers, reviewers, builders, and inspectors to provide playgrounds that function well, are attractive, and have properly installed play equipment, whether the playground being constructed is for a homeowners' association or an agency.

Tot Lots

The children who will use a tot lot can generally be broken into 2 age groups: 6 months to 2-1/2 years and 2-1/2 to 5 years. Both age groups must be accommodated in the same tot lot. To a 6 month to 2-1/2-year-old toddler who is just learning to walk, climb, etc., 6" is tall and 3' is a mountain. The 2-1/2-to 5-year-old is looking for more challenges to improve motor and mental skills, so achievement-oriented play equipment is a must. Tot lots should have a variety of simple shapes, bright colors, and a maximum height of five feet (5').

Pre-Teen

The child who will use the pre-teen lot will range in age from 5 years old to 12 years old. The playground needs to provide just as much fun, adventure and challenge for the 5-year-old as the 12-year-old. The children in this age group have a lot of energy to expend and it is generally expended in short duration. A playground that provides a series of activities with a "starting point" that becomes progressively more difficult will be the most successful. There are no height limitations in this age group.

Park Playgrounds

Playgrounds for parks are broken into the same 2 basic categories, tot lots and pre-teen lots. However, the square footage devoted to particular age group will increase from the required minimum for a subdivision as stated in the subdivision requirements. Prior to the final construction plans being drawn for a

CAREFULLY SELECT PLAY EQUIPMENT THAT IS APPROPRIATE FOR THE AGE AND SIZE OF THE USER.

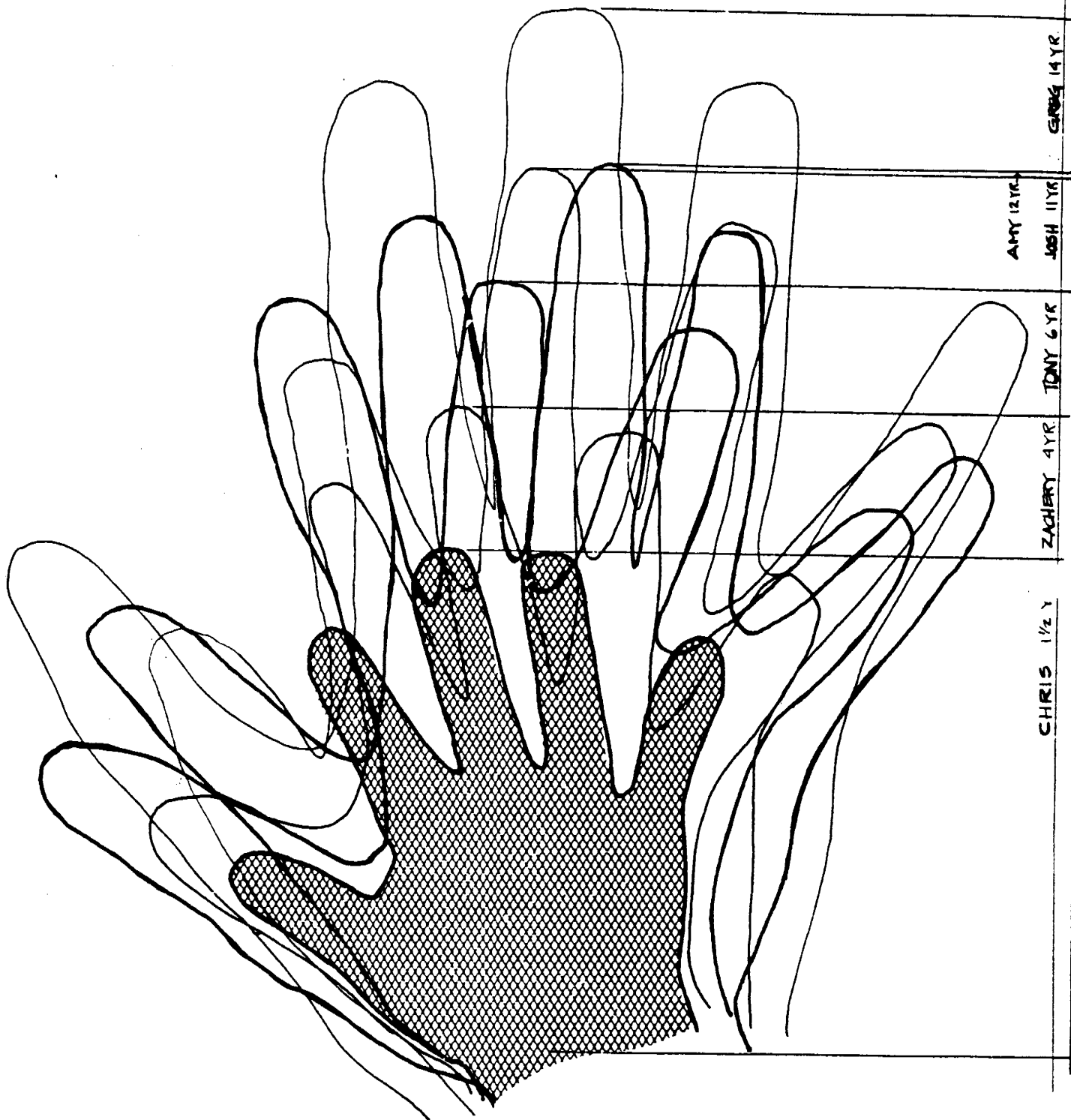

**TYPICAL HAND SIZES FOR CHILDREN
(COMPARE YOURS)**

park playground. discussion is to take place between the designer and Maintenance and Development Division to determine the need for edging.

The population of the subdivision is based on a per unit figure from the Planning Department, multiplied by the proposed number of dwelling units.

Unit type X persons/unit type=projected population.

A playground is to be sited in conjunction with other facilities as part of a central recreation area. If the subdivision requires 2 or more tot lots and/or pre-teen lots, they are each to be different to provide a series of play opportunities linked by a path. Playgrounds should be away from picnic area to cut down on broken glass and trash. The surveys also indicate that the most important thing is that the playground be conducive to play.

DESIGN REQUIREMENTS

1. Required

1 - 2,400 sq. ft. minimum tot lot/500 persons in subdivision

1 - 5,000 sq. ft. minimum pre-teen lot/750 persons in subdivision

2. Size

1 - 2,400 sq. ft. minimum tot lot

1 - 5,000 sq. ft. minimum pre-teen

3. Categories of Play Opportunities to be Provided in each Playground

Category number 1: Select a minimum of 3:

Climbing

Rolling (may be provided on adjacent slope of 2:1 to 4:1)

Crawling

Sliding

Category number 2: Select a minimum of 2:

Swinging (minimum of 4 participants in 5,000 square foot area - groups of 3 not allowed).

Spinning

Springing/Bouncing

Category number 3: Select a minimum of 3:

Balancing

Hanging

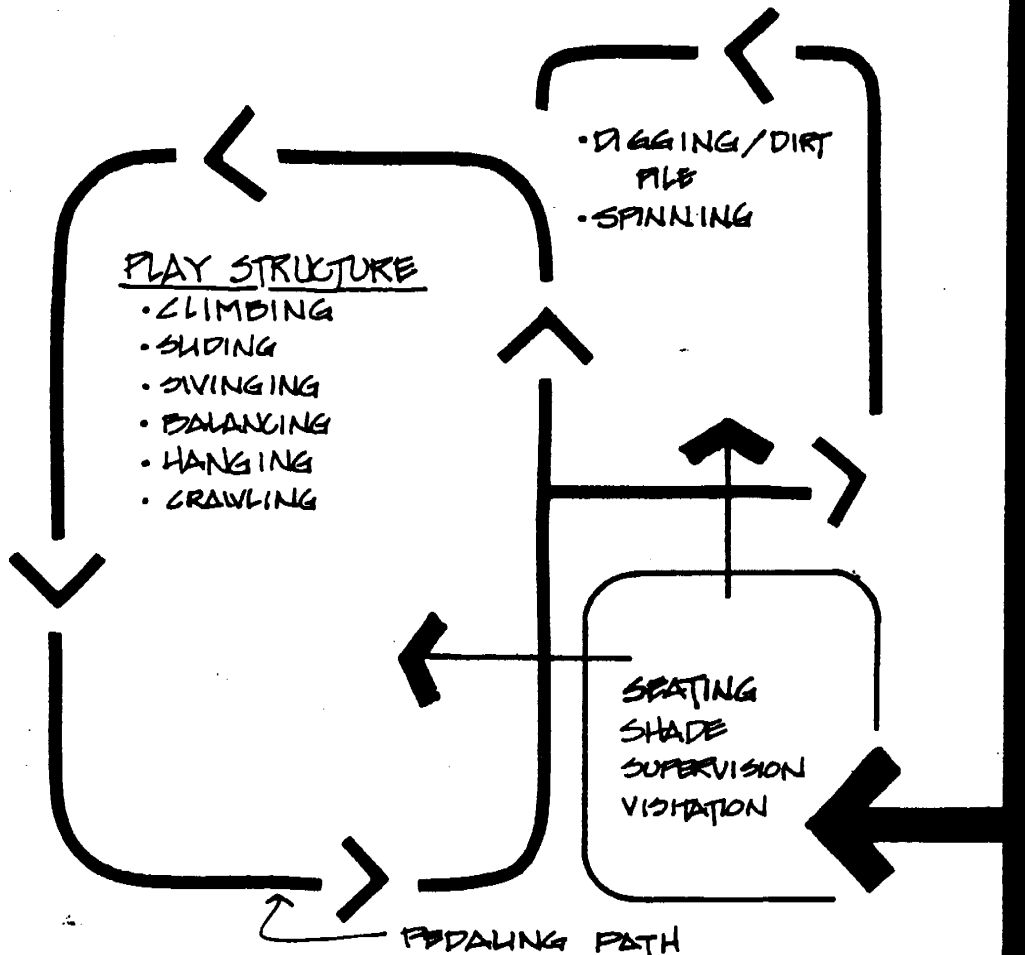

NOTES

1. 1 TO 3% SLOPE
2. POSITIVE DRAINAGE
3. EASY AND READY ACCESS TO WALKWAY TRAIL SYSTEM
4. BUFFER FROM HOMES
5. PROVIDE SET BACKS TO STREETS, HOUSES
6. 5000 SQUARE FOOT PRE-TEEN LOT
7. 5 TO 7 YEAR OLD USERS
8. MAXIMUM HEIGHT - 12'

Hiding/Enclosure

Digging (5 cubic yards of soil in pile separated by header material).

4. Configuration of Playground: Playgrounds can be nearly any shape that a suitable edging can be built around. (Curves are difficult because straight timbers are utilized). Generally, make playgrounds sufficient in size to provide ample safety distance around equipment. Generally provide playground that has a width that is 3/4's of the length i.e., 75' x 100'. Irregular - vary shapes with one end larger than the other, octagonal, pentagon etc.

5. Accommodation:

Tot lot: 2,400 sq. ft. minimum (10 children)

Pre-teen: 5,000 sq. ft. minimum (15 children)

Parks: neighborhood - will require greater square footage than 5,000 - 10,000 square feet.

community - will require greater square footage than 5,000 - 10,000 square feet.

regional - will require greater square footage than 5,000 - 15,000 square feet.

6. Seating

Provided for adult supervision: Minimum of 12' benches should have galvanized legs and be anchored in concrete. Other types of seating, brick walls, timber walls are also encouraged.

7. Access All playgrounds are to have direct access to hard-surfaced path system.

8. Siting

- A. 30' setback from any building or 25' from dwelling lot line, and 30' from property lines, whichever is greater.
- B. 30' setback from parking lot, access drives, etc.
- C. 50' setback from highways.
- D. Tot lots are to be a minimum of 20' from pre-teen lots.
- E. 3% gradient maximum, 2% minimum, unless terraced or specifically designed for unusual equipment (i.e., hill slide, tire climbers).
- F. Playgrounds are not to be sited in, on or under any of the following conditions: (These areas* may be utilized if sufficient site plan detail is provided, i.e., location of switch boxes, depth of pipes.

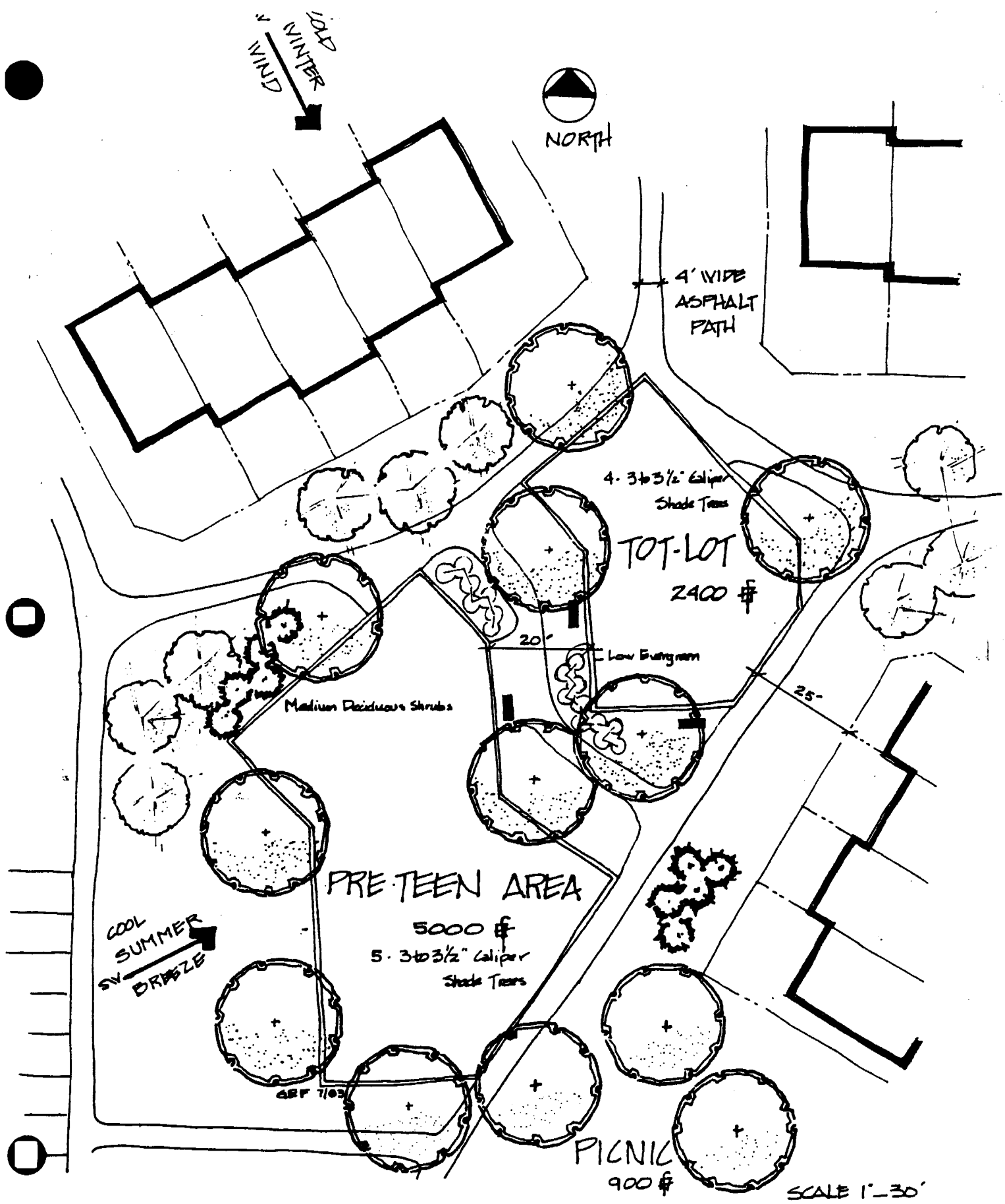

TYPICAL TOT LOT AND PRETEEN AREA SITING

wires, width of easement, etc.) Utility companies will not replace equipment that they removed in order to do repairs.

- a. 100-year flood plain
 - b. Utility lines*
 - c. At the bottom of drainage courses
 - d. Easements*
 - e. Areas utilized as sediment control ponds*
- G. If a tot lot is provided near a tennis court so children can play while parents use the courts, the tot lot should be fenced with a 4' chain link fence that has a gate that locks from the outside.
- H. Earthen berms with landscaping will be considered in place of setbacks if it is superior.

9. Edging Detail # A 1

Pressure treated wood-42 square inches minimum (old or new railroad ties are not desirable; field experience has shown the creosote causes skin burns).

Set timbers square in ground and anchor with #4 diameter rebars 3'0" in length, 2-1/2' apart, minimum 3 per timber.

Substitutions not allowed unless approved by Department of Parks and Recreation.

10. Surface Detail # A 1

The following are acceptable surface materials:

Wood chips - 6" deep, size 1/2" minimum-3/4" maximum; chips to be hardwood and free of all noxious weeds.

Tanbark - spread 6" deep-size 1/2" minimum 3/4" maximum (severe problem with matting and rapid decomposition. Use sparingly and only when wood chips are unavailable).

Sand - is not permitted in playgrounds because of health problems (cats & dogs).

11. Shading Required

Tot lot 2,400 sq. ft.; minimum - 4 trees, 3" to 3-1/2" caliper - 3 guy wires per tree @120° apart. First branch 6' above ground.

Pre-teen-5,000 sq. ft. minimum - 5 trees 3" to 3-1/2" caliper - 3 guy wires per tree @120° apart. First branch 6' above ground.

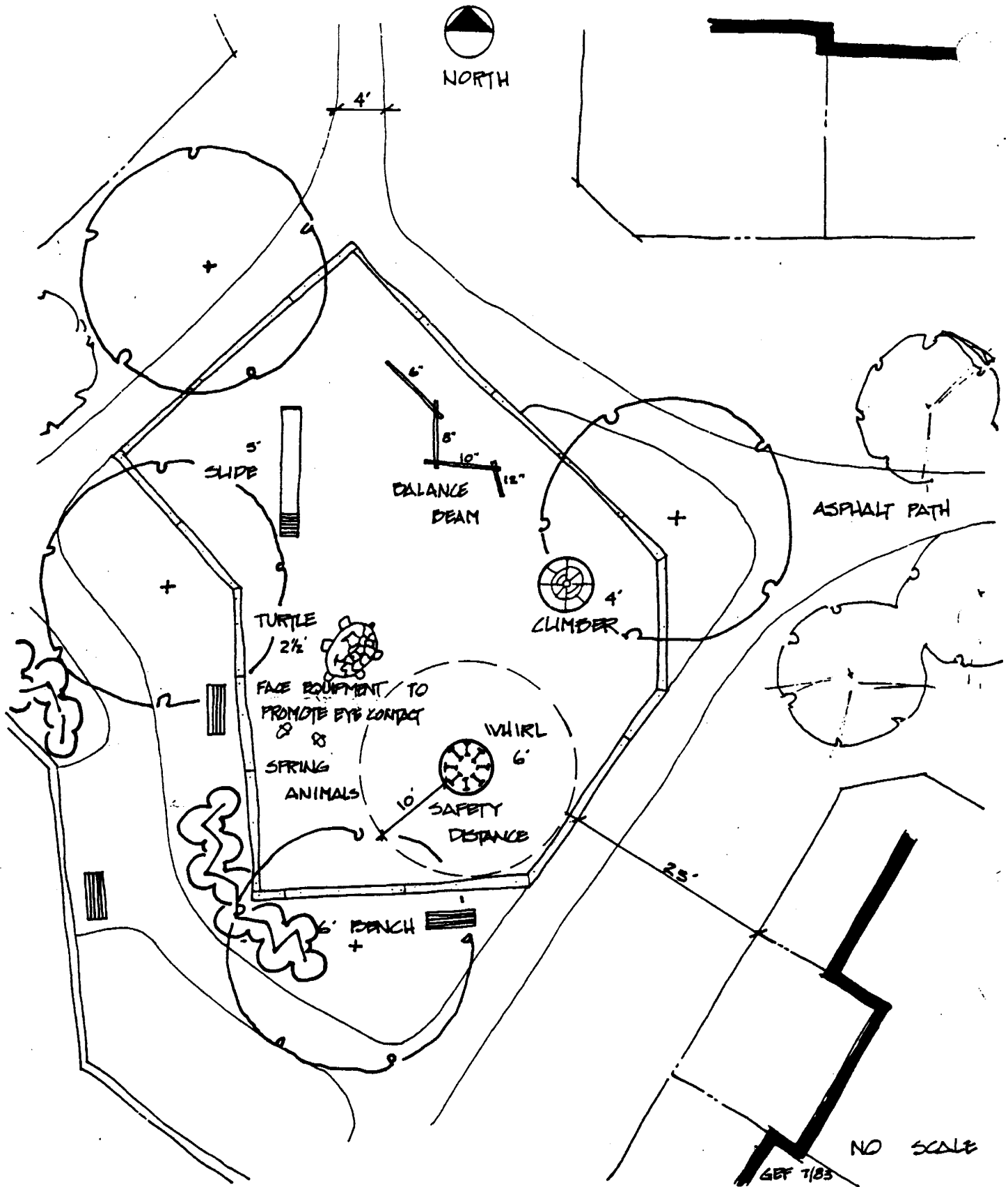

Playgrounds that are sited in existing stands of trees are not required to provide additional shade if sufficient shade is available. site plan is to indicate the size and type and location of existing trees to be retained.

12. Safety

Provision of a safe playground is of primary importance to the future users. Fifty percent (50%) of playground injuries are due to unsafe equipment. The designer should take careful note of the way a piece of equipment is to be used and provide adequate distance between the pieces. Needless injuries occur when equipment is crowded together, i.e., a slide that empties onto a see-saw which is 3' away. Whirls produce centrifugal forces from which children can be hurled and swings become either pendulums or catapults from which children may fall or jump. Slide faces are to face north to insure that the metal will not heat up and burn "bottoms".

Modular Versus Static Equipment

A child uses his playtime as a means of socialization and not to just burn off energy. It is important to consider the socialization of play when selecting equipment. The modular equipment that contains platforms allow children to participate in groups for creative play i.e., games such as follow the leader, pirates, cowboys, poison sea and indians are important learning experiences for children. Static equipment may not provide platforms, however, careful siting may promote this type of activity.

TYPICAL PLAYGROUNDS

TOT LOT 6 MONTHS TO 5 YEARS

EXAMPLE A

Combination Wooden Equipment Components

- 1-enclosed area (hiding) category #3
- 1-slide (sliding) category #1
- 2-tire swings (swinging) category #2
- stepping blocks (climbing) category #1
- 1-balance beam (balance) category #3
- 1-chin bar (hanging) category #3

Separate Equipment

- 1-whirl (spinning) category #2
- 1-grass hill adjacent (rolling) category #1

EXAMPLE B

Equipment

- 2 - spring animals (2') (bouncing/springing) category #2
- 1 - turtle (2-1/2') (climbing) category #1

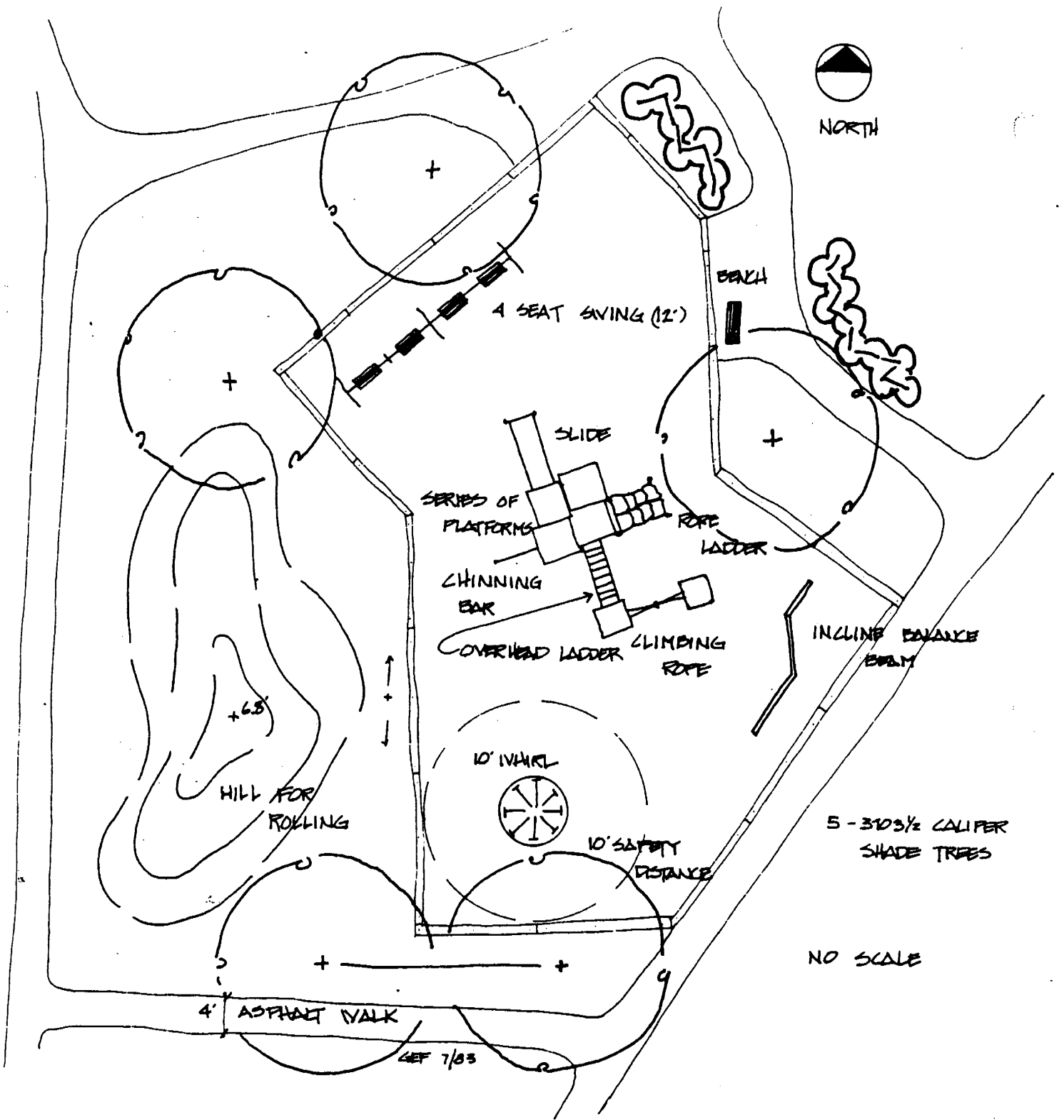

5 - 30 3/4 CALIPER SHADE TREES

NO SCALE

PRETEEN AREA EXAMPLE A PAGE 50

- 1 - whirl (6') (spinning) category #2
- 1 - slide (5') (balancing & sliding) category #3 & #1
- 1 - climber (4') (hanging & climbing) category #2 & #3
- 1 - balance beam (6") (balancing) category #3

PRE-TEEN (5 YEARS TO 12 YEARS)

EXAMPLE A

Combination Wooden Equipment Components

- 1-climbing rope (climb) category #1
- 1-chinning bar (hang) category #3
- 1-slide (sliding) category #1
- 1-balance beam (balancing) category #3
- 1-overhead ladder walk (hanging) category #3

Separate Equipment

- 4 - seat swing (swinging) category #2
- 1 - 10' whirl (spinning) category #2
- grass hill adjacent (rolling) category #1

EXAMPLE B

- 1 - 10' climber (climbing) category #2 & #3
- 1 - 12' slide (sliding) category #1
- 1 - 8' whirl (whirling) category #2
- 1 - balance beam (balancing) category #3
- 1 - 4-seat swing (swinging) category #2
- 1 - barrel (rolling) category #1
- 1 - overhead ladder walk (hanging) category #3
- 1 - 10'x10' dirt pile (digging) category #3

Safety Tips

1. 10' clearance required from outside of whirl.
2. Move swing couplings 6" out from perpendiculars.
3. Don't run walks into equipment.
4. Site slide face facing north.
5. Slides should have a 10' clearance at end.
6. Swings should be placed away from other equipment.
7. Use rubber strap seats for swings.
8. Footings need minimum of six (6)" dirt covering.
9. Swing seats should be steel belted to prevent slashing.

PLAN REQUIREMENTS

Preliminary Plat Requirements

1. Show location of playgrounds and designate either pre-teen or tot lot.

2. Indicate setbacks

Site Plan Requirements

Site development drawings are to contain:

1. Grading, including spot elevations;
2. Surface material;
3. Exact location of equipment and safety distances;
4. Shade trees species and sizes;
5. Location of any fences, buffers, etc.

6. List of Facilities to be placed on Site Plan

KEY	QUANTITY	NAME	CATALOG NO.	MANUFACTURER

7. Try to limit number of equipment companies used in playgrounds for a particular development to make it easier to order replacement parts.
8. All details and cross-sections and specifications needed to construct facilities are to be placed on site development plans.
9. Under the heading of general notes, the following is to appear:

"All substitutions of playground equipment are to have prior approval from the Department of Parks and Recreation".

For more information on playgrounds refer to:

A Playground for All Children Books 1, 2 and 3. United States Department of Housing and Urban Development. January 1976, August 1976, May 1978.

Hand Crafted Playgrounds M. Paul Freidburg, Random House, N.Y. March 1975

Article "Childs Play is Not Child's Play" by Donald V. Joyce March/April 1978 Issue of The Penn Stater.

TIMBER EDGING 6'x8'x8'0" LONG (TYPICAL) LONGER LENGTHS ACCEPTABLE. PRESSURE TREATED. CONSTRUCTION GRADE MEETING MSHA STANDARD FOR STRUCTURAL TIMBER AND WOLMAN SALTS.

TIMBER EDGING TO BE SET SQUARE ON GROUND, WITH 8' FACE DOWN.

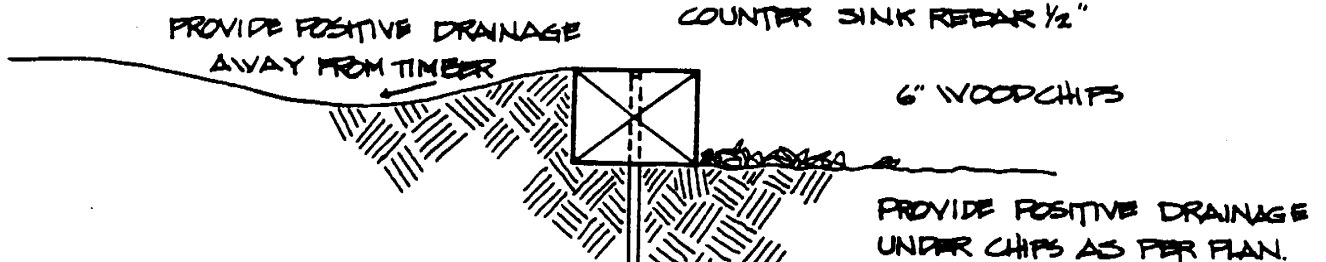

1. No 4 REBAR - 36" LENGTH COUNTER SINK 1/2" DRIVE AT SLIGHT ANGLE - 3 PER TIMBER
2. COMPACT SUBGRADE TO 90%
3. WOODCHIPS TO BE 2" MAXIMUM & 3/4" MINIMUM. HARDWOOD ONLY, FREE OF ALL NOXIOUS PLANTS - I.E. POISON IVY, SUMAC. CHIPS ARE TO BE UNTREATED.

CROSS SECTION
NO SCALE

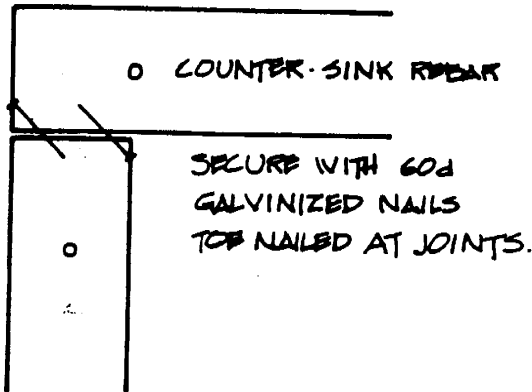

PLAN VIEW
NO SCALE

CROSS SECTION AND PLAN VIEW OF EDGING

PLAYGROUND

PARKS AND RECREATION FACILITIES
GUIDELINES © M-NO7PC 1983

DEPARTMENT OF PARKS & RECREATION STANDARDS & SPECIFICATIONS, Prince George's County



Date Approved: 8/3/03
James E. Fuller M.A. R.L.A. # 287

Drawn
MNA
GFF

Date
7/05

Revised	Date

**DETAIL
A1**

Division of Planning, Design & Research

MARYLAND NATIONAL CAPITAL
PARK & PLANNING COMMISSION

SITTING AREA

A sitting area is a facility that provides opportunities for socializing between residents of a neighborhood, rest stop or a walk thru, a subdivision or woods, bus stop. One aspect of a sitting area not usually thought of is that it will provide security in an area by making people more visible.

Subdivision Requirement

A sitting area is to be provided at the rate of 1 per 500 persons in a proposed subdivision. The population of the subdivision is based on a per unit figure from the Planning Department times the proposed number of dwelling units.

Unit type X persons/unit type=projected populations.

A sitting area is to be sited in conjunction with other facilities as part of a central recreation area; placed in a natural setting; or sited in an "urban setting". The sitting area may also be broken into two (2) one-half (1/2) sitting areas. A sitting area may be deleted and another facility provided in its place.

DESIGN REQUIREMENTS

1. Required

1 - 200 sq. ft. sitting area per 500 persons (a chess table with benches may be used as a substitute for a bench)

2. Equipment

4 - 6' benches with backs and galvanized legs.

3 - 2-1/2-3" caliper shade trees; first branch at 6' (3 guys/tree 120° apart)-(1/2 sitting areas require 2-2'1/2-3" caliper shade trees each).

3. Siting

A. Site on a maximum 3% gradient and a minimum 2% gradient unless specifically designed for special equipment or terraced.

B. Siting areas are not to be sited in, or under any of the following conditions: (*However, these areas may be utilized if sufficient site plan detail is provided, i.e., location of switch boxes, depth of pipe wires, width of easement, etc.). Utility companies will not replace equipment that they remove to do repairs.

- a. Utility lines*
- b. Drainage courses
- c. Easements*
- d. Under power lines

C. Sitting areas may either be in a urban or natural setting. Sitting areas work well as part of a central recreation area.

GENERAL DESIGN INFORMATION

a. Urban

Benches should be placed in an area where people will logically congregate to talk or to walk. Some examples are either a bus stop, or a landscaped lawn or paved area in front of units. Benches should be placed at least 3' back from the walk so people walking by do not trip over the feet of those sitting on the benches.

TYPICAL URBAN SITTING AREA

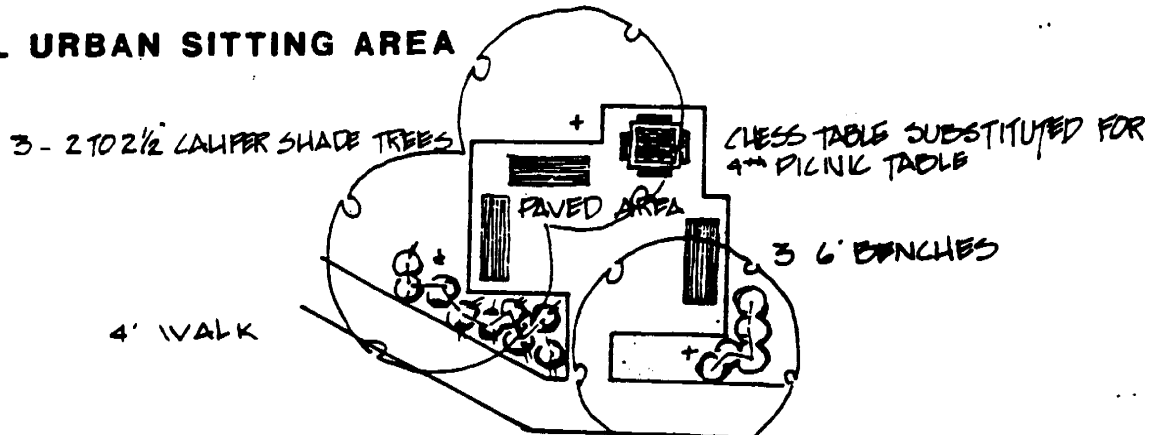

ILLUSTRATION # 5.1

b. Natural

A natural sitting area should be sited on trails that lead to and from portions of the subdivision. Benches should be set back 3' from path. These areas will most likely be sited where there are existing trees. If sufficient shade exists, then no additional trees will be required. The area is to be selectively cleared and grubbed removing all noxious vines, weeds, and all dead trees in proximity (10') to the benches. Tree branches are to be removed to 8'. Take advantage of whatever scenic views there may be and place the sitting areas accordingly. The area is to be mulched with 4" of tanbark or wood chips. Place a special note on the plan to allow field adjustment if situation calls for it.

TYPICAL NATURAL SITTING AREA

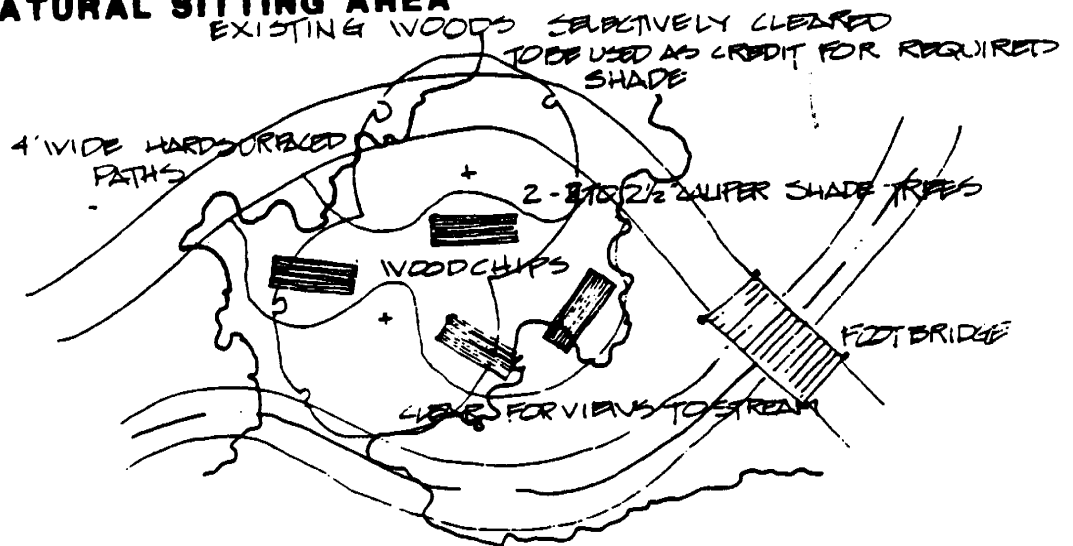

ILLUSTRATION # 5.2

c. Central Recreation Area

Sitting areas can be incorporated into the main recreation area in many ways. A waiting area for pick-up from ballgames or swimming pools, an area from which to view others participating in activities or an area to rest from an activity.

TYPICAL SITTING AREA FOR CENTRAL RECREATION AREA

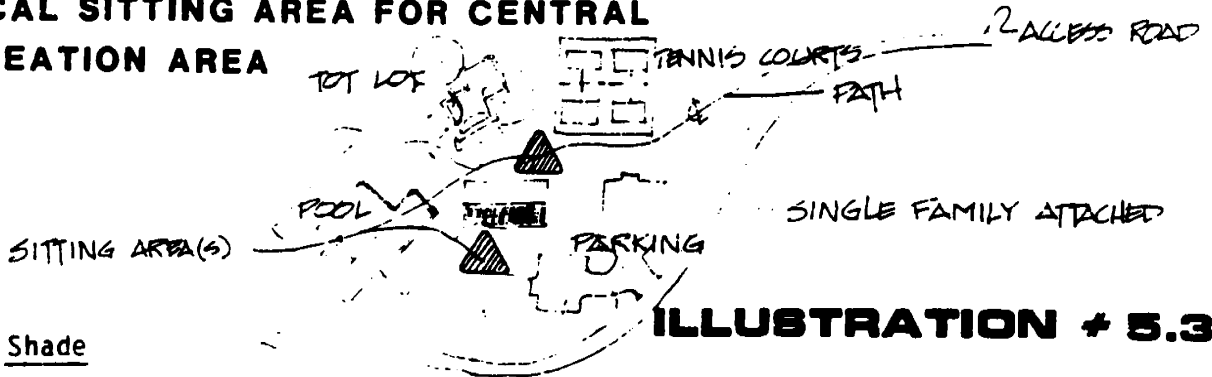

ILLUSTRATION # 5.3

4. Shade

A bench or sitting area must be shaded. Three 2-1/2" - 3" caliper shade trees are required per area. An urban setting may use manmade shade in the form of architectural canopies, etc. If sufficient shade exists from existing tree stands, the area is to be selectively cleared and grubbed and mulched with 4" of wood chips or tanbark. Written specification and construction details are not required unless the benches to be used are not standard. General site notes are required only on the Site Development Plan.

PLAN REQUIREMENTS

Preliminary Plat/Comprehensive Design Plan Requirements

The preliminary plat shows the location of the half or whole sitting areas, whether it is in an urban or natural setting, or sited in the central recreation area.

Site Plan/Specific Design Plan Requirements

Site development drawings are to contain:

1. Site grading;
2. Spot elevation;
3. Landscaping;
4. Shade trees or existing trees to be retained; site plan must have size, type and location of trees to be saved;
5. Selective clearing line;
6. Equipment list.

Detail Sheet Requirements

1. Footings;
2. Tree planting detail;
3. Layout.

PICNIC AREA

One picnic area is to be provided at the rate of 1 per 500 persons in a proposed subdivision. The population of the subdivision is based on a per unit figure from the Planning Department, multiplied by the proposed number of dwelling units.

Unit type x persons/unit type=projected population.

A picnic area is to be sited in conjunction with other facilities as part of a central recreation area or be broken into two (2) one-half (1/2) picnic areas. Recent park surveys indicate that the picnic area should be kept away from playgrounds to reduce the amount of trash and glass in the playground and that enjoyable views and vistas are very important to user.

DESIGN REQUIREMENTS

1. Required

2. Size

900 sq. ft. - This allows approximately 5' from table to table and an 8' square area for grill.

3. Equipment

1 - 900 sq. ft. picnic area per 500 persons.

3 - 6' anchored picnic tables with either galvanized legs or wooden table per Detail # **B1**.

1 - 8' anchored picnic table modified for wheel chair use with either galvanized legs, or wooden table per Detail # **B1**.

1 - grill with galvanized leg anchored in concrete.

1 - trash receptacle with a galvanized leg.

4 - 2-1/2 to 3" caliper shade trees staked with guy wires @120° (unless sufficient existing trees are maintained), site plan is to indicated the size, location, and type of existing trees to be retained.

4. Siting

The picnic area is to be sited on a 1 to 3% slope in a grove of existing trees, or four 4-2-1/2 to 3" caliper shade trees are to be provided (first branch at 6' from the ground) per picnic area. Site away from playground to reduce trash and glass. Recent park surveys indicate the most important items to users about a picnic area are that it be conducive to picnicking, have enjoyable views and vistas, and be clean.

Picnic areas are not to be sited in or on any of the following conditions:

(*However, these areas may be utilized if sufficient site plan detail is provided, i.e., location of switch boxes, depth of pipe wires, width of easement, etc.) utility companies will not replace equipment that they have removed to do repairs.

- a. 10-year floodplain;
- b. Utility lines;
- c. Must be set back 25' from parking lot and roads;
- d. At the bottom of drainage courses;
- e. Power lines.

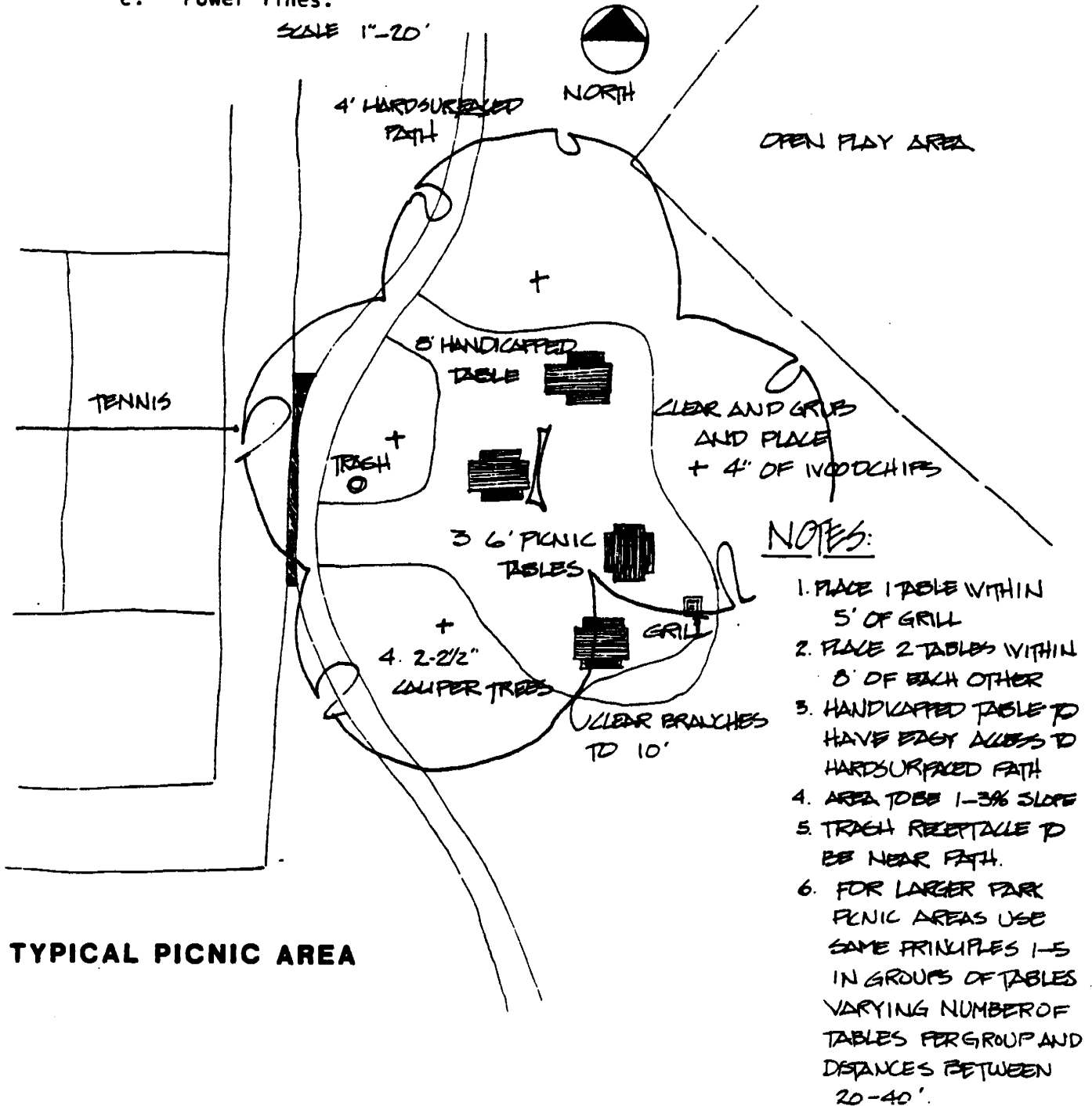

TYPICAL PICNIC AREA

ILLUSTRATION # 6.1

5. Shade

Picnic areas must be sited in shade (after all, who wants to picnic in the hot sun). Shade provided by existing trees is preferable. Wooded areas should be selectively cleared (safety is an important factor, therefore, the ability to see in and out of the area is of great importance), removing all dead trees, injured trees, trees under 4" caliper (unless flowering), poison ivy, sumac, and greenbriar. Picnic tables and grills are to be anchored in concrete although placed in a natural setting. The trash receptacle should be sited in proximity to the path for easy accessibility of trash pick up. Tree branches are to be cleared to 8 feet.

PICNIC AREA CROSS SECTION

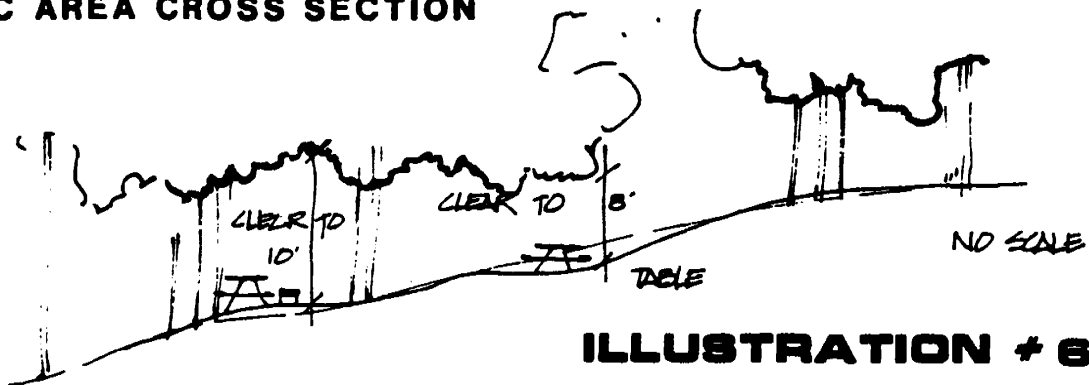

ILLUSTRATION # 6.2

Picnic areas that are built in areas void of trees are to have four-2-1/2 to 3" caliper shade trees set 25' on center. The trees are to have 3 guy wires 120° apart. The lowest branch is to be 6' from the ground.

6. Anchoring. Detail # B2

All picnic tables are to be anchored whether placed in a public park or in a private development.

Site Plan Requirements

Site development drawings are to contain:

1. Site grading;
2. Spot elevations;
3. Landscaping;
4. Shade trees, or existing trees to be maintained;
5. Selective clearing line;
6. Tree planting detail;
7. Bench, grill, and tree location;
8. Limit of woodchips.

Park Picnic Area

Picnic table groups of 10 tables two grills and 1 trash receptacle for every 3 tables. Tables are either galvanized or wood (Detail #B2) to be anchored, and trash receptacles may be either single leg anchored or 50 gallon oil drum modified as per Detail #B3. Design principles as noted on illustration number 6.1 are to be applied a park picnic area.

PLAN REQUIREMENTS

Written Specifications

Not required unless the picnic tables, grills, trash receptacles, etc., to be used are not standard. General site notes only are required.

Preliminary Plat/Comprehensive Design Plan Requirement

The preliminary plat is to show the location of the picnic area and its proximity to other facilities.

Site Plan/Specific Design Plan Requirements

Site development drawings are to contain:

1. Site grading;
2. Spot elevation;
3. Landscaping;
4. Shade trees or existing trees to be retained;
site plan must have size, type and location of trees to be saved;
5. Selective clearing line;
6. Equipment list.

Detail Sheet Requirements

1. Footings;
2. Tree planting detail;
3. Layout.

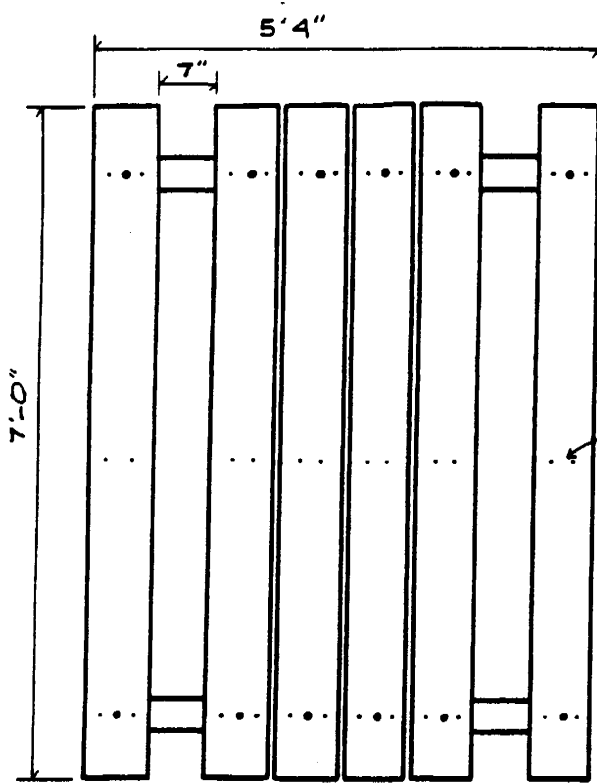

TOP VIEW
SCALE 1"-2'

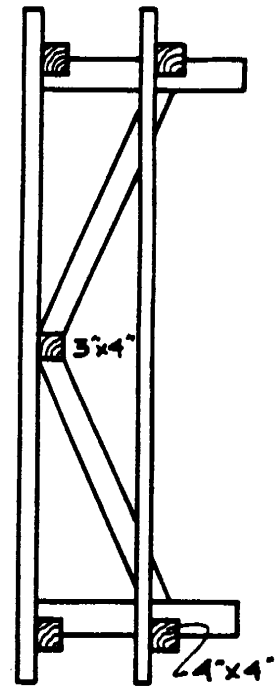

SIDE VIEW
SCALE 1"-2'

NAIL 20d
CARRIAGE BOLT
3/4" x 8" GALVANIZED
BOLT - PEBB BOLT

MATERIAL: PRESSURE TREATED YELLOW PINE.

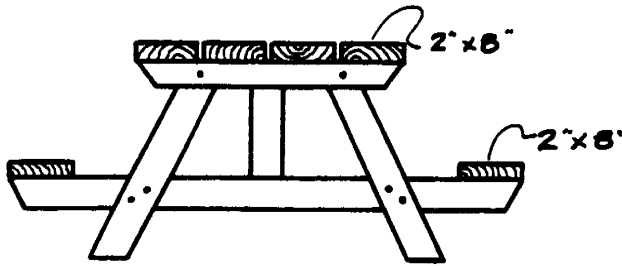

END VIEW
SCALE 1"-2'

NOTE:
HANDICAPPED TABLE TO BE BUILT BY EXTENDING TOP ON ONE END BY TWO FEET.

WOODEN PICNIC TABLES

PICNIC AREA

PARKS AND RECREATION FACILITIES
GUIDELINES © MNCPPC 1983

DEPARTMENT OF PARKS & RECREATION STANDARDS & SPECIFICATIONS, Prince George's County



Date Approved: 8/3/83
James E. Fadden Md. BIA # 387

Drawn
MNN/GEF

Date
8/83

Revised	Date

**DETAIL
B1**

Division of Planning, Design & Research

MARYLAND NATIONAL CAPITAL
PARK & PLANNING COMMISSION

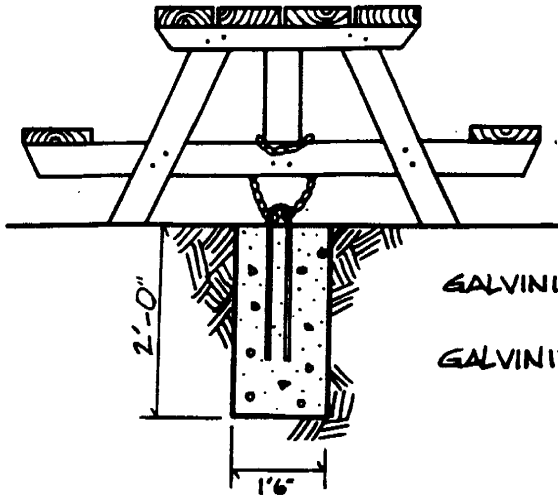

WOODEN PICNIC TABLE

GALVINIZED STEEL CHAIN; 1/4" DIAMETER; 1" STRAIGHT LINKS
 GALVINIZED STEEL REBAR #4.

NOTE:

ANCHOR PICNIC TABLES TO PREVENT THEFT, ANCHOR ONE END ONLY

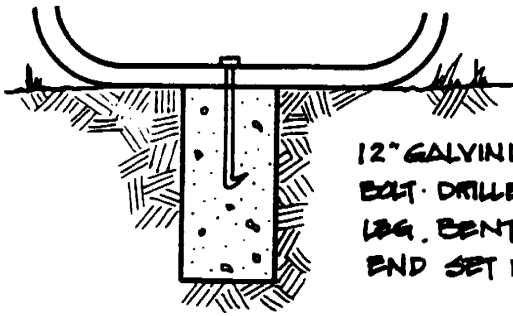

1/2" GALVINIZED STEEL BOLT DRILLED THROUGH LEG. BENT AT OTHER END SET IN CONCRETE.

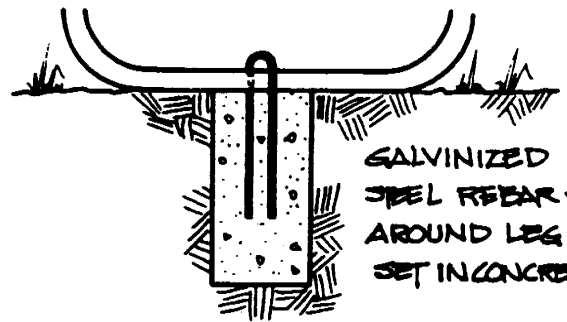

GALVINIZED STEEL REBAR #4 AROUND LEG SET IN CONCRETE.

PICNIC TABLE ANCHORS

PICNIC AREA

PARKS AND RECREATION FACILITIES
 GUIDELINES © M-NEPPC 1983

DEPARTMENT OF PARKS & RECREATION STANDARDS & SPECIFICATIONS, Prince George's County



Date Approved: 8/3/83

Grace E. Fielder Md. RIA #387

Division of Planning, Design & Research

Drawn
 MNM
 GEF

Date
 7/83

Revised

Date

MARYLAND NATIONAL CAPITAL
 PARK & PLANNING COMMISSION

DETAIL

B2

SIDE VIEW

TOP VIEW

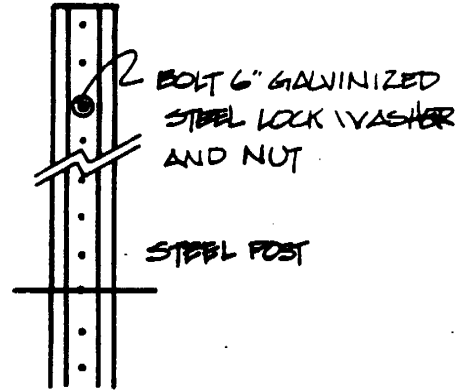
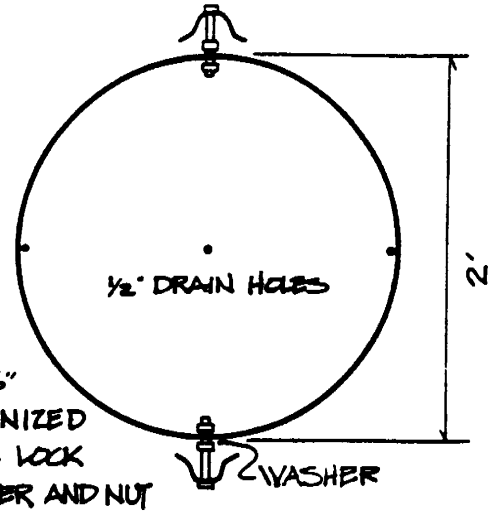
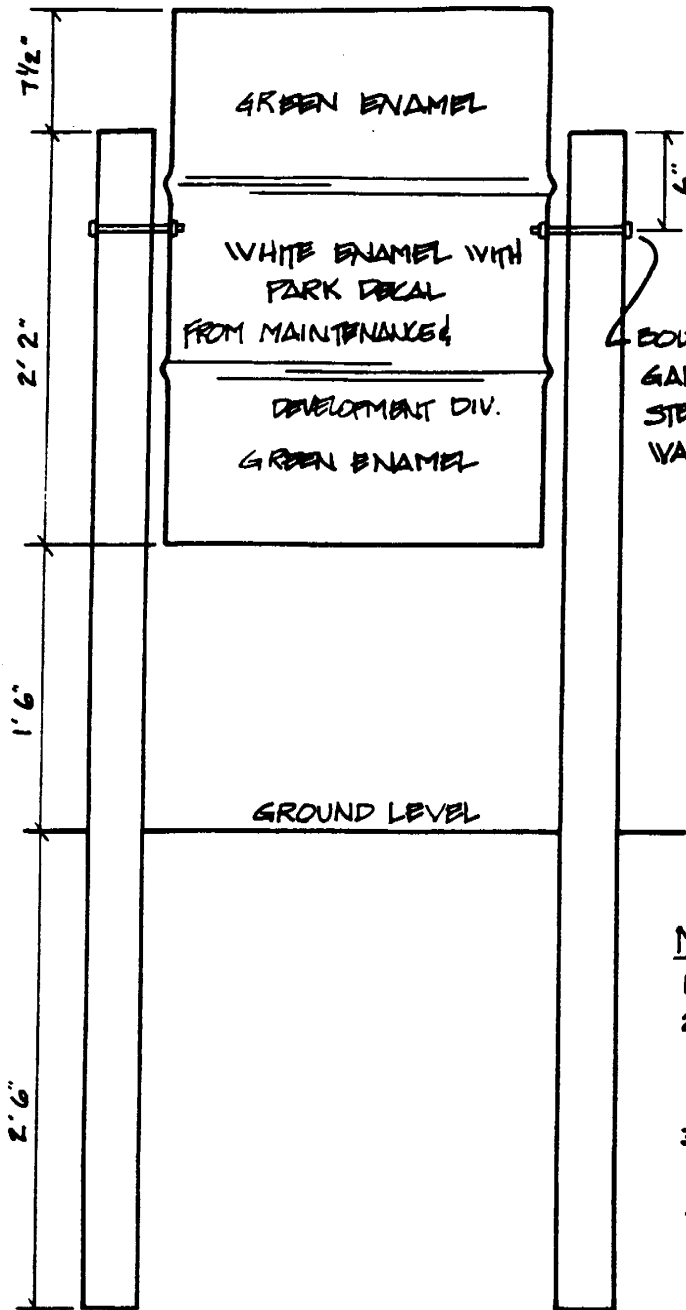

NOTES:

1. BARREL TO SWING FREELY
2. 4" STEEL GALVANIZED POST 7' TO 8' OR 4 X 4" X 7' OR 8' PRESSURE TREATED POST.
3. POST TO BE MINIMUM 2' 6" IN GROUND
4. 50 GALLON RECYCLED STEEL DRUM. REMOVE ALL FUMES BEFORE CUTTING - FUMES MAY IGNITE CAUSING EXPLOSION.
5. FOR SUBDIVISIONS USE BROWN ENAMEL.

SCALE: 1" = 1'-0"

TRASH RECEPTACLE

PICNIC AREA

PARKS AND RECREATION FACILITIES
GUIDELINES © M-NPPC 1983

DEPARTMENT OF PARKS & RECREATION STANDARDS & SPECIFICATIONS, Prince George's County



Date Approved: 8/3/83
Grace E. Fielder Md. PLA # 357.

Drawn
MNM
GEP

Date
7/83

Revised

Date

DETAIL

B3

Division of Planning, Design & Research

MARYLAND NATIONAL CAPITAL
PARK & PLANNING COMMISSION

OPEN PLAY AREA

The open play area is one of the few facilities, that knows no age limits. The facility can provide a much needed sense of community, provide visual green relief, and a place for young and old to play. The open play area will be used for unstructured play, i.e., football, catch, frisbee, tag, kite flying, etc.

An open play area is to be provided at the rate of 1 per 500 persons in a proposed subdivision. The population of the subdivision is based on a per unit figure from the Planning Department, multiplied by the proposed number of dwelling units.

Unit type x persons/unit type=projected population.

An open play area is to be sited in conjunction with other facilities (i.e., picnic, tot lot, pre-teen, basketball, etc.) to act as a central recreation area for development. The open play area is an excellent facility to separate picnic areas and playgrounds. This separation will help to control the amount of glass down and trash found in playgrounds.

DESIGN REQUIREMENTS

1. Required

1 - 100'x200' open play area per 500 persons.

2. Size

100'x200' open play area - 2 to 3% slope with center crown (Detail #C1)

3. Orientation - any orientation is allowable.

At no time should the open play area be sited directly east/west.

4. Siting

Open play areas are not to be sited in, on or under any of the following conditions:

- a. Power lines;
- b. 10 year flood plains;
- c. Manholes;
- d. Within 25' of an access drive/road, building or property line and within 15' of dwelling lot line.

5. Compaction - 90%

6. Drainage

Maximum slope in is 3%, minimum slope is 2%. A definite crown is to be placed on the facility as shown in Detail #C1.

PLAN REQUIREMENTS

Preliminary Plat and Comprehensive Design Plan Requirement

The preliminary plat is to show the location of the open play area(s) and its relationship to paths, recreation facilities, parking lots, property lines, and buildings.

When the open play area is properly sited, it will add a much needed place to play in addition to an important visual relief in a dense development.

Site Plan and Specific Design Plan Requirements

Site development drawings are to contain:

1. Spot elevations;
2. Site grading;
3. Landscaping;
4. Paths;
5. Setback lines.

Detail Sheets

Detail sheets are to contain a layout of open play area showing dimensions and written specifications tailored for the specific site.

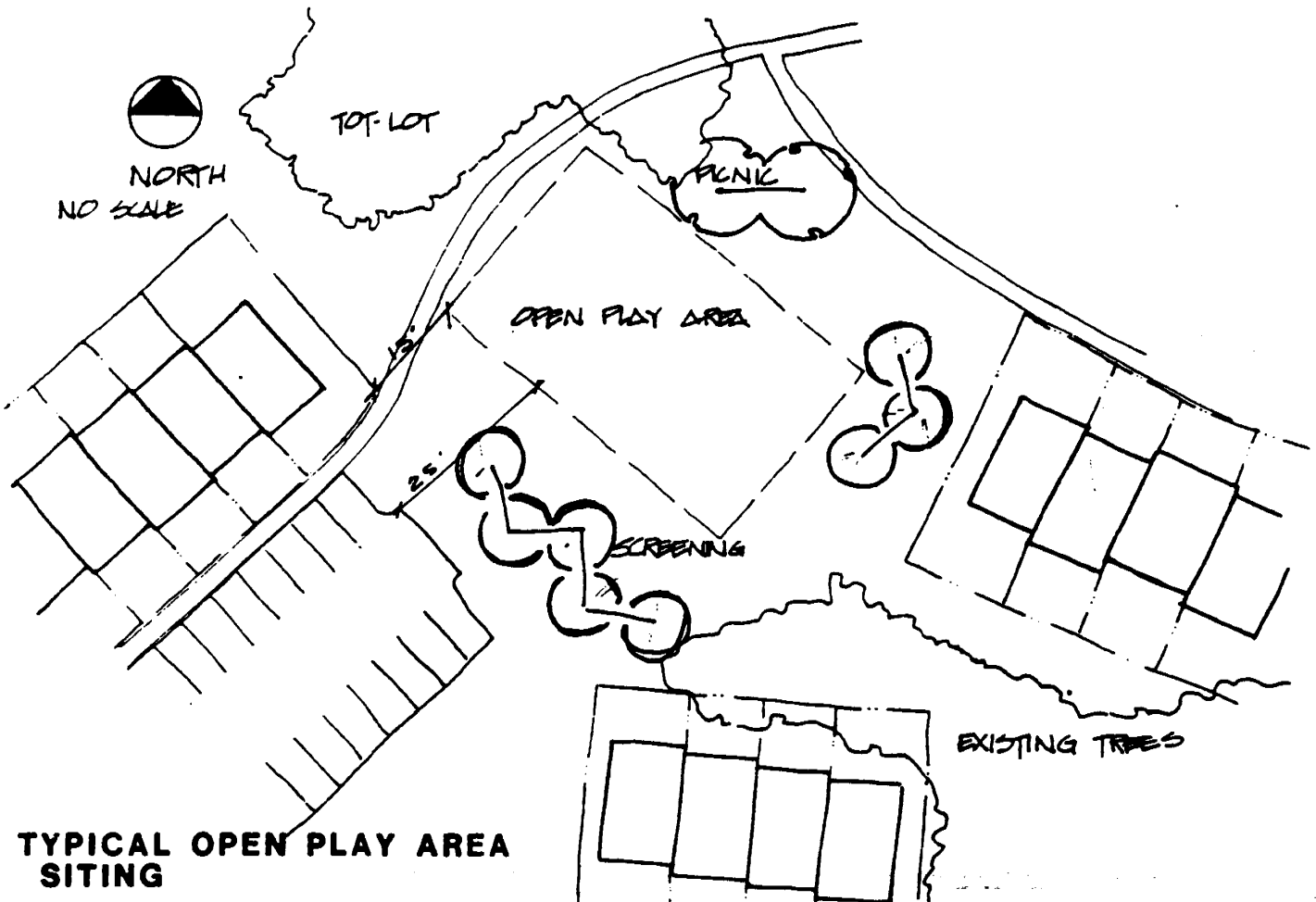

ILLUSTRATION # 7.1

CONSTRUCTION SPECIFICATIONS

1. SCOPE

Labor, material, equipment and services necessary to complete excavation and site work as shown on drawings. Work includes excavating, pumping, backfilling, and rough grading to elevations shown for completion of work as hereinafter specified.

2. CLEARING SITE

The site development plan shows areas to be cleared.

(a) Clearing:

(1) Limits of clearing shall be confined to those areas as shown on the plans or as required by the typical grading and paving sections. Clearing line to be marked in field by Contractor. Activity by the Contractor beyond these limits shall be at the authorization of the Engineer and/or Landscape Architect. At several locations the grading may have to vary slightly to avoid destruction of specimen trees.

(2) Clearing shall include demolition and removal of all trees, saplings, brush, downed timber, shrubs, rotten wood, rubbish, vines, undergrowth, and any other vegetation from area of open play and walkways. Clearing shall also include other trees as shown on the plans and so designated for removal. Demolition shall include root system of trees, as well as the removal of fences and incidental structures.

(b) Grubbing:

(1) Limits of grubbing shall coincide with limits of clearing, unless otherwise specified.

(2) Grubbing shall include removing from the ground all stumps, roots and stubs, brush, organic materials, and debris within the limits of grubbing.

(c) Disposal:

(1) Burning of materials on site shall not be permitted.

(2) Where chips are to be utilized on a site the trees may be chipped.

The following generally pertain to parkland development.

(3) All trees shall be thoroughly chipped and used as mulch on site. Chipped material shall be stockpiled on site, as shown on the plans.

(4) Maximum size chipped particles shall be three (3) inches in any dimension.

(d) General:

(1) Contractor shall visit the site to determine the existing conditions and shall be held responsible for all demolition covered under these specifications.

(2) The Contractor's attention is specifically directed to MSHA Specifications, Section 31.01-12, Subparagraphs 1 and 7, referring to tree trimming and scar repairs.

(e) Field Quality Control:

(1) Engineer and/or Landscape Architect shall approve the clearing line prior to any clearing.

(2) After clearing and grubbing has been completed, the Engineer and/or Landscape Architect is to inspect damage to remaining trees and shall direct the Contractor to repair damage by a professional tree surgery firm at no expense to the Owner.

(f) Demolition on Site:

(1) Protection to Persons and Property: All work shall be scheduled and executed in a careful manner with due consideration for workmen and public, and to prevent injury to any persons or property.

(2) Use of Explosives: Do not do any blasting on the project site without written permission of the Engineer and unless it is done in accordance with applicable laws and regulations.

(g) Clean-Up:

(1) Remove from site any stumps, dead trees, broken and loose branches, rubbish, and debris resulting from demolition, unless otherwise specified.

(2) Leave the site in a safe, clean condition.

(3) After demolition and removal work is completed, do not store on site any materials resulting from demolition or any tools and equipment used for work.

3. GRADING

The grading plan shows the extent of areas to be graded. All grades shall be in accordance with plans.

- (a) Soil Tests: Soil tests have not been made to determine the characteristics of the soil and the level of the water table except as shown on the plans.
- (b) Subsurface Conditions: The Contractor is to examine information shown on the plans, and is to examine the site, making such tests as deemed necessary to determine the conditions and the nature of the soil.
- (c) Bench Marks and Monuments: Carefully maintain all benchmarks, monuments and other reference points; if disturbed or destroyed, replace as directed.
- (d) Finished Grades: Refer to the required grade elevations indicated. If finished grades shown by spot elevations conflict with those shown by contours, spot elevations shall be used. Unless indicated, project site area shall be given uniform slopes between points for which finished grades are shown, or between such points and existing established grade, except vertical curves or roundings shall be provided at abrupt changes in slope. Do all grading required to bring the entire project area to finished grades.
- (e) Debris: Remove from site all debris and excavated material not suitable, or not needed for fill.

4. SITE DRAINAGE

(a) GENERAL

See Site Development Plan.

(b) SCOPE

The contract work to be performed under this section consists of all the required labor, material, equipment, and services necessary to complete site drainage, as shown on the drawings.

5. TOPSOIL, SEEDING AND SOD

(2) Scope:

- (1) Sodding and seeding are to be as included in the contract.
- (2) The contract work to be performed under this section consists of all the required labor, material, equipment, and services necessary to install topsoil, as shown on the drawings or as specified herein.
- (3) Expose the smallest practical area of land at any one time during development.

- (4) Make provisions to effectively accommodate the increased runoff caused by changed soil and surface conditions during development.
- (5) Natural vegetation must be retained and protected.
- (6) The permanent final vegetation and structures must be installed as soon as practical in the development of this site.

(b) Topsoil:

- (1) Stripped topsoil is to be reasonably free of woody plants, stones over one inch (1)" in size, construction debris, excavated material and deleterious matter.
- (2) Topsoil is to be approved by the Engineer and/or Landscape Architect before installation to consist of a sandy loam containing 2 to 2.5% organic matter free of debris, rock and gravel.
- (3) Furnish and spread four inches (4") of topsoil over disturbed areas.
- (4) Spread evenly to true contours and hand rake to an even, smooth surface ready for seeding.
- (5) Regrade and fill low spots after shrinkage.
- (6) Existing topsoil, if acceptable, may be used as far as it will go. New topsoil to be brought in, as necessary, to build up required grading. Any tests required to determine quality of topsoil, both existing and new, made where and as directed by, the Engineer and/or Landscape Architect. at no expense to the Owner (Owner refers to M-NCPPC).

(c) Seeding:

- (1) Grass seed shall be Maryland State Certified and mixed in the following percentages by weight:

<u>SEED</u>	<u>PERCENT OF MIX</u>	<u>PERCENT GERMINATION</u>	<u>PERCENT PURITY</u>	<u>PERCENT WEED SEED CONTENT</u>
Kentucky Bluegrass	10	75	85	.40
K-31 Fall Fescue	90	85	98	.50

(2) Seeding Operations

Seed shall be sown at the rate of 6-8 lbs./1,000 square foot, or 250 lbs./acre.

The seed shall be spread by mechanical spreaders at the rate previously specified. Seeding shall be done in two directions, the second being perpendicular to the first using one-half of the amount of seed in each direction. The seed shall be in firm contact with the seed bed and raked into the top one-fourth inch (1/4") of topsoil. The Contractor shall have the option of rolling the seed into the topsoil, rather than raking. If the Contractor elects to roll, the roller shall weigh no more than 150 pounds.

- (3) Fertilizer shall be a commercial chemical fertilizer, 50% of the nitrogen of which is derived from natural organic sources of ureaform. The fertilizer shall contain the following percentages by weight:

20% Nitrogen
20% Phosphoric acid
10% Potash

Fertilizer shall be applied at the rate of 220 pounds per acre to the areas to be seeded and/or sodded.

- (4) Ground Limestone shall conform to MSHA, Article 20.05, Section 20.05-3.

- (5) Water shall be clean and potable, suitable for drinking.

- (6) Straw Mulch shall consist of thoroughly threshed wheat, rye, or oat straw.

- (7) Binder Terra Tac AR or approved equal.

- (d) Sod:

Sod shall be cultivated bluegrass-fescue mixture grown in an established turf nursery. Sod shall be free of insects, grubs, and apparent disease, and shall show proof of a current Nursery Inspection Certificate.

- (1) Sod shall have been mowed prior to stripping and shall have been maintained for a minimum of three (3) months at or near the height of final clipping at the nursery. Maximum height: two and one-half inches (2-1/2").

- (2) Sod shall be machine stripped at a uniform soil thickness of approximately one (1) inch, plus-or-minus one-quarter (1/4) inch. Though thinner cuts tend to accelerate knitting and are, therefore, preferred, the minimum acceptable soil thickness shall be three-quarter (3/4") inch. Measurement for thickness shall include the growth and thatch.

- (3) Individual pieces of sod shall be cut to the supplier's standard width and length. (Maximum allowable deviation from standard width and length is five (5) percent.) There shall be no broken pads, torn or uneven ends.
- (4) In no event shall more than forty-eight (48) hours elapse between the cutting and planting of the sod.
- (5) Before placing sod upon any surface, all shaping and dressing of such surfaces shall have been completed to the grades on plan. The completed areas to be sodded shall present a smooth, uniform, well tilled surface, and any raking required to accomplish this shall be done immediately prior to the placing of the sod.
- (6) Sodding shall be performed during the proper season for such work. No frozen sod shall be used, and no sod shall be placed upon frozen soil.
- (7) Maintenance - Sod shall be kept moist until it has become established, and its continued growth assured, or until accepted.
- (8) Slopes - On slopes two-to-one (2:1) and steeper, sod shall be laid with the long edges parallel to the contour starting at the bottom of the slope. Succession strips shall be neatly matched, and all joints staggered or broken. When placing sod in drainage ditches, the length of the strip shall be laid parallel to the direction of the flow of the water.
- (9) Each strip or section of sod placed on slopes two-to-one (2:1) and steeper, and surface drainage V-shaped or flat bottom ditches or gutters, shall be staked securely with at least two (2) stakes spaced not more than two feet (2') apart with the flat side against the slope. Stakes may be wood wedges and shall be 1/2" x 1" x 12" to 1/2" x 1" x 15" driven flush with the top of the sod.
- (10) Guarantee - Sodded areas which do not show a prompt catch shall be resodded at no expense to the Owner.

6. MULCHING

The mulch shall be applied over the seeded areas in an approved manner. The rate of application shall average 115 pounds per 1,000 S.F., with a minimum of 90 pounds and a maximum of 140 pounds per 1,000 S.F., so as to provide a loose depth of not less than one and one-half inches (1-1/2") nor more than three inches (3").

Uniform distribution and depth of mulch must be obtained. After the mulch is in place, all mulched surfaces shall be sprayed with binder material so that the surface has a uniform appearance. The binder shall be applied to the mulch at the rate of eight (8) gallons per 1,000 S.F. A spray nozzle of approved design shall be used. The nozzle shall be operated at a distance of not less than four (4') feet from the surface of the mulch. A pump or air compressor of adequate capacity shall be used to insure uniform distribution of the bituminous material.

7. TIME OF SEEDING AND SODDING

March 1 to May 1 and August 1 to October 31, inclusive.

8. MAINTENANCE

The Contractor shall maintain all seeded and sodded areas for a period of not less than 45 days nor more than 60 days. Maintenance shall consist of watering, weeding, mowing, repairing of all erosion and settlement, and reseeding or resodding of lawn areas, as necessary, to establish a weed free, dense, closely knit turf of the grasses specified.

At the time of the first mowing, mower blades shall be set between two and two and one-half inches (2-2-1/2"). All newly seeded and sodded areas shall receive at least three (3) mowings before acceptance of lawns. Remove all grass clippings during or immediately after mowing.

Maintenance shall also include any temporary protection fences, barriers, and signs, as well as all other work incidental to proper maintenance.

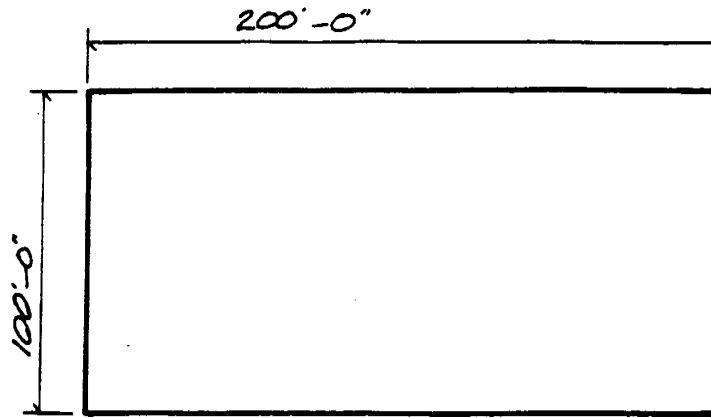

PLAN VIEW

DRAINAGE PATTERNS

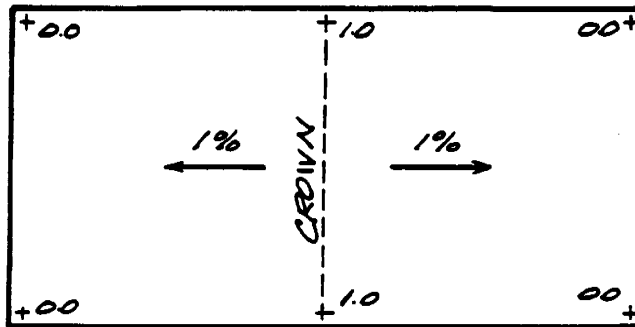

ALTERNATIVE 1

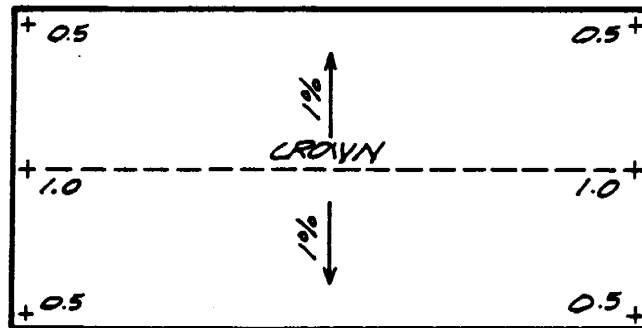

ALTERNATIVE 2

SCALE 1"=60'

PLAN VIEW AND DRAINAGE

OPEN PLAY AREA

PARKS AND RECREATION FACILITIES
GUIDELINES © M-NCPPC 1983

DEPARTMENT OF PARKS & RECREATION STANDARDS & SPECIFICATIONS, Prince George's County



Date Approved: 8/3/83

Grant E. Jellison Md. PLA # 387

Division of Planning, Design & Research

Drawn
MNM
GRF

Date
7/83

Revised _____

Date _____

MARYLAND NATIONAL CAPITAL
PARK & PLANNING COMMISSION

DETAIL
C1

BASKETBALL /MULTI PURPOSE COURT

A basketball court is an extremely versatile facility that can be modified to allow six one-on one games to be played simultaneously. Additional strips may also be added to create a multi-purpose court that allows volleyball.

The courts may be fenced for a more urban setting where player safety may be in conflict with roads or parking lots. If light is provided in the courts, it will give more hours of play. Care must be taken in siting of a court in a subdivision to minimize the noise of ball bouncing that will annoy residents. A basketball court of multi-purpose court may not be appropriate in every development.

A basketball court is to be provided at the rate of 1 per 750 persons in a proposed subdivision. The population is based on a per unit figure from the Planning Department multiplied by the proposed number of dwelling units.

Unit type X person/unit type=projected population.

A basketball court may be sited singularly or in conjunction with other facilities in order to form a central recreation area for a particular subdivision.

The basketball court is to be sited so as to have direct access from a hard-surfaced path.

DESIGN REQUIREMENTS

1. Required

- 1 - 60'x90' basketball court per 750 persons
- 1/2 - 60'x50' basketball court per 375 persons

2. Size

- Full Court - 60'x90' includes apron (Detail #D1)
- Half basketball court - 60x'50' (includes apron) (Detail #D2)

3. Orientation

The basketball court is to have a direct north south orientation, to benefit the greatest number of players directly. In extremely difficult siting situations, the courts may be rotated 15° northeast.

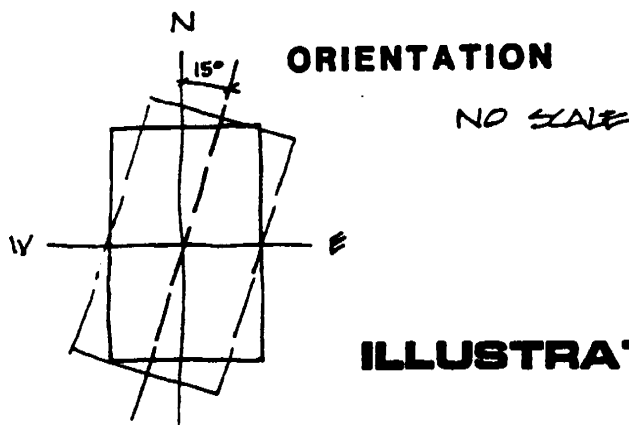

ILLUSTRATION #8.1

4. Siting

Basketball court(s) are not to be sited in, under, or on any of the following:

- a. 100-year floodplain;
- b. Utility lines or easements;
- c. Areas that are to be utilized for sediment control ponds;
- d. Within 25' of parking lot, property or lot lines;
- e. Within 40' of access drive or road;
- f. Bottoms of drainage courses;
- g. Within 50' of a dwelling;
- h. Poor soils that are susceptible to shrink, swell and slippage.

5. Compaction: 95% (See written specifications).

6. Drainage: (Detail # D9)

Maximum 1% slope in any direction. Spot elevations to be shown on site development plan in all four corners and center court line.

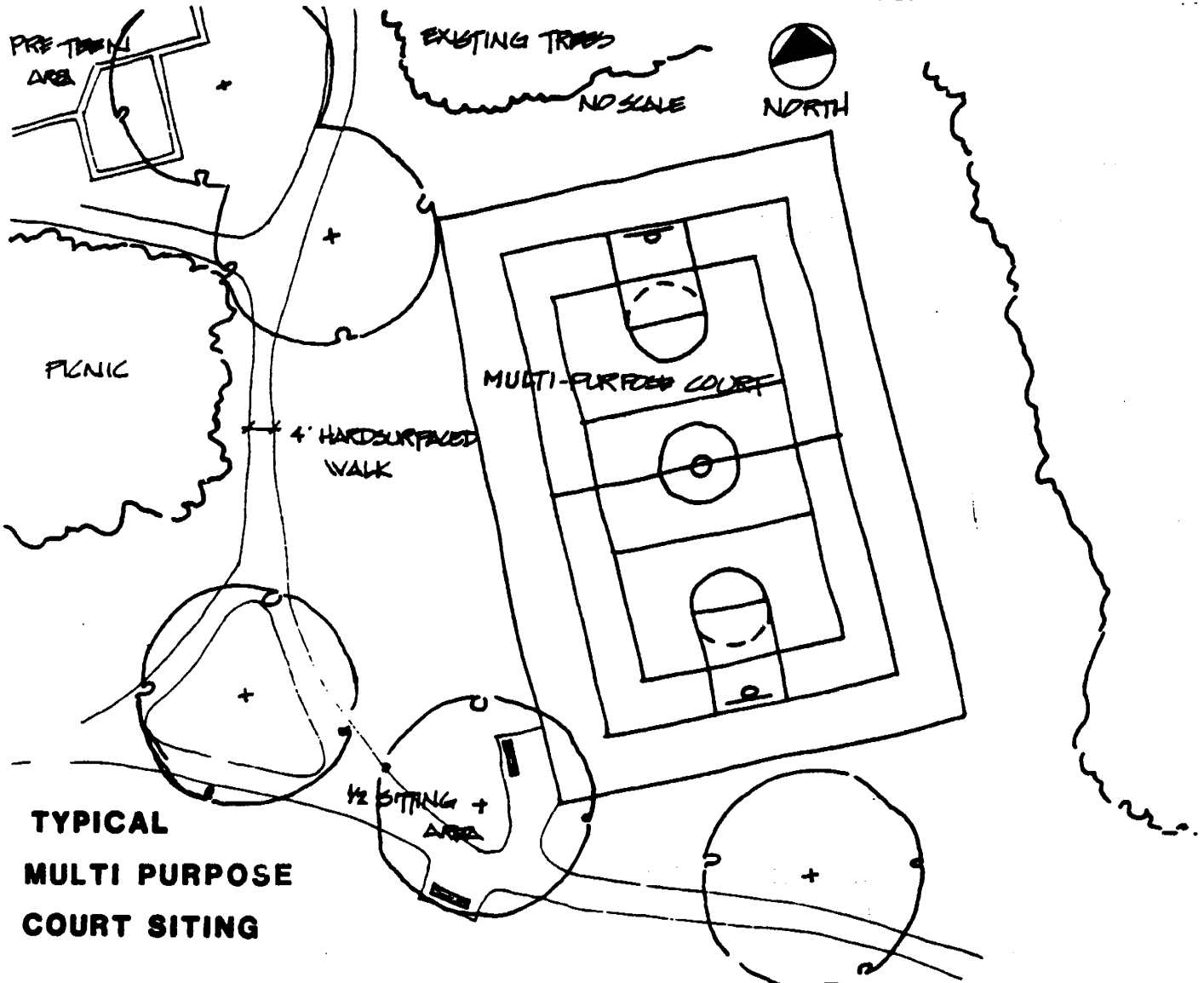

Occasionally, it will be necessary to deviate from the preferred drainage patterns; however, the court(s) must still meet all the above requirements for orientation, compaction drainage, siting, etc.

7. Backstops - single pole, galvanized 2-7/8" diameter minimum. (Detail #D7)

DESIGN OPTIONS

Suggested Additions to Improve Facility

Buffering:

No buffering of multi-purpose court will be required unless the courts are sited in such a way as to be unsightly or noisy for adjoining homes. By necessity, some of the buffering will have to be evergreen, but may include an attractive combination of fences, flowering and evergreen trees.

Fencing: (Detail #D8)

There is no requirement for fencing of basketball courts. Developers may want to fence with a ten foot 10' high fence and a gate with a lock to prevent play in late night hours. A fence is a very good idea in high density development.

Shading

When a basketball court is to be constructed in an area that is void of existing trees, a shaded area shall be provided for player and spectator comfort. Shade may be provided by shade trees or man-made structures. If trees are used use those that are low in trash (i.e., willow oak, locust). Site to cast shade onto the court during late morning to mid-afternoon hours.

Seating

1 - six foot (6') permanent bench with back should be provided for each court.

The bench shall be located in an area that will allow view of play on the courts as well as provide shade from the late morning to mid-afternoon sun.

Color Coating (Detail #D2)

Although color coating is not required for basketball courts, it is strongly suggested because it extends the life of the court, provides a better playing surface, is a more attractive facility, and is more easily maintained.

Additional Basketball Backstops

It may be more beneficial at times to provide fewer courts and a greater number of backstops.(Detail #D3&4)indicate the correct layouts. The court(s) can then be utilized for one-on-one play in addition to regulation play.

MULTI PURPOSE COURT

Subdivision Requirement: None

Multi-purpose courts should be sited in an area of high density urban development where a grass or sand volleyball court cannot be provided.

Size

Full court, 60'x90' includes apron (Detail # D5)

The remainder of information is the same as for basketball courts.

Nets and Poles for Volley' all

To be provided to the Homeowners' Association at the time of final site inspection.

PLAN REQUIREMENTS

Written Specifications and Construction Details

All courts are to be constructed to these standards and specifications. The standards and specifications have been used successfully for years by the M-NCPPC. The applicable written specifications and details are to be made a part of the site development plans. The subdivider and/or his designers may find it necessary to modify the specifications and details to fit a specific site.

Preliminary Plat and Comprehensive Design Plan Requirements:

The preliminary plat is to show the location of tennis courts and their relationship to paths, property lines, parking and other recreational facilities.

Site Plan and Specific Design Plan Requirements:

Site Development Plan is to contain:

1. Site grading
2. Spot elevations
3. Landscaping
4. Paths
5. Buffering and landscaping

- 6. Setback lines
- 7. Seating

Detail sheet to contain:

- 1. Layout
- 2. Fencing
- 3. Entrances
- 4. Written specifications
- 5. Cross sections

CONSTRUCTION SPECIFICATIONS

1. GENERAL REQUIREMENTS

- a. **SCOPE OF WORK TO BE DONE:** The contract work to be performed under this section consists of furnishing all of the required labor, materials, equipment, implements, parts, and supplies necessary for, or appurtenant to, the installation of basketball court and/or multi-purpose court(s), in accordance with the drawings and as further elaborated in these specifications.
- b. **STANDARDS:** The work hereunder shall be done in a thorough workmanlike manner. Any reference to a specification or designation of the American Society for Testing and Materials, Federal Specifications, or other standards, codes, or orders refers to the most recent or latest specification or designation. Where names of specific products may be designated in these specifications or in the details appearing on the drawings, the intent is to state the general type and quality of product desired without ruling out the use of other products of equal type and quality, provided that use of such other products of equal type and quality has been approved in writing by the Owner or his representative with prior approval from the Department of Parks and Recreation.
- c. **LAYOUT OF WORK:** The work shall be laid out to true lines and grades in full accordance with the drawings. Surveying of lines and grades, from a base line and bench mark established by the Owner at the construction site, and staking therefore shall be accomplished by the Contractor. Monuments shall be substantially established, protected, and maintained in place by the Contractor for the duration of the contract or until such other time as their removal may be authorized by the Owner or his representative.
- d. **CLEARING AND GRUBBING:** Trees and other vegetation including their root systems to a depth of not less than twelve inches (12") shall be removed from the site and the soil treated with a sterilant that will effectively inhibit future growth of flora. Sterilant to be approved by the Engineer and/or Landscape Architect and limited to use beneath areas to be paved.

2. FILL AND COMPACTION

Minimum Class II fill required in all areas to be paved or that have footings. Class III fill may be utilized in grassed areas, with a minimum of 12" cover.

- a. **MATERIALS:** (1) All borrow materials used in earth fill or backfill must meet the following specifications and may be rejected on visual inspection pending testing and samples. Fill and backfill materials shall be a well-graded combination of granular materials and silt clay soil. Materials shall have no more than 70% percent passing #4 sieve, and no more than 10% percent #200 sieve. No gravel or stone shall be larger than 1/3 the depth of the layer to be placed.

Soil shall have a liquid limit, as determined by current AASHTO Standard Methods of "Determining the Liquid of Soils" T89, of not greater than 40 and a plasticity index as determined by current AASHTO Standard Methods of Calculating the Plasticity Index of Soils of not more than ten. Material to be used shall be free from trash, brick, broken concrete, tree roots, sod, ashes, or cinders.

(2) Samples shall be submitted at least one week in advance of desired date of approval. Acceptance of material from any location shall be construed as approval of entire location only insofar as material continues to meet these specifications.

(3) Materials from this site shall be deemed satisfactory only insofar as they conform to this section on the specifications.

- b. **FILL AND BACKFILL CONSTRUCTION:** Wherever the term "Maximum dry density" is used, it shall be determined in accordance with AASHTO Designation T-99 Field Determination of Density of Soils in Place, Sand Method.

Materials prescribed herein for fill and backfill shall be deposited in uniform layers not to exceed eight inches in thickness, loose measurements, and each layer shall be compacted, to not less than 95 percent at maximum dry density. Material shall be placed at a moisture content approximately equal to optimum.

- c. **DRAINAGE:** Keep excavations free from water. Where subgrade is wet contractor shall take whatever steps are necessary to drain and dry out to optimum moisture contents, including ditching, drain tiles, and pumping at no cost to the Owner.
- d. **SUBGRADE PREPARATION:** Subgrade shall be compacted so that it is firm, hard, and unyielding. It shall be compacted to 95% of dry weight density as determined by AASHTO Designation T-99 Method A. After compaction, it shall be true to lines and grades as set forth in the plans. After final rolling, the subgrade shall be tested with a ten foot (10') straight edge laid parallel with the sides of the pavement and any depressions or high spots exceeding normal tolerances shall be corrected.

All soft and unstable material and any other portions of the subgrade which will not properly compact, or serve the purpose intended, shall be removed and disposed of and replaced with material approved by the Engineer and/or Landscape Architect.

The Engineer and/or Landscape Architect shall be notified and shall inspect and approve the sub- base prior to any paving.

3. BITUMINOUS SURFACING

- a. **GENERAL:** In general, all work performed under this item shall be in accordance with Item 42, of the Prince George's County General Specifications and Standards for Highway and Street Construction dated July, 1965, or its update.
- b. **BASE COURSE:** Compacted bituminous surfacing material shall be as detailed on the drawings prepared by the applicant. A careful check shall be made to insure that a complete bond is made between each pour. All areas exceeding a tolerance of 3/8 inch, with a ten (10) foot straight edge, at the time of the pour, shall be repaired immediately and brought to the required elevation. The entire area shall be carefully checked immediately after placing the bituminous concrete, and thoroughly rolled. Rolling shall be accomplished in both directions and all wheel and roller marks, etc., shall be thoroughly rolled and removed. Samples of the finished mix shall be tested to determine gradation and asphalt cement content.

Note: Asphaltic concrete mixtures shall not be placed or spread when the base or supporting course is damp or when other weather conditions prevent proper spreading, finishing, or compaction. A tack coat of Ae-4 or RC-250 in the amount of .05 gallons per square yard shall be applied to the top of the base and binder courses prior to placing the surface course. Tack coat may not be required if base and/or binder course is freshly placed and thoroughly clean.

- c. **SURFACE COURSE:** One (1) inch of compacted bituminous surfacing material, as detailed on drawings, shall be spread over the entire area utilizing a self-propelled bituminous paving machine. The spreading shall be brought up to a true and even surface at the proposed finished grade. A careful check shall be made to insure a complete bond is made between each pour. All areas exceeding a tolerance of 1/8 inch with a ten (10) foot straight edge, at the time of the pour, shall be repaired immediately and brought to the required elevation. The entire area shall be carefully checked immediately after placing the bituminous concrete and thoroughly rolled. Rolling shall be accomplished in both directions and all wheel and roller marks, etc., shall be thoroughly rolled and removed. Samples of the finished mix shall be tested to determine gradation, and asphalt cement content.

4. POST AND FOUNDATIONS

- a. **CONCRETE:** Concrete for foundations shall be mixed in ratios of not less than four and one half (4-1/2) standard 94-pound sacks of cement per cubic yard of concrete, with one (1) such sack of cement to not more than a compressive strength of not less than two thousand five hundred (2,500) pounds per square inch at the twenty-eighth (28th) day after pouring. Foundations shall be as indicated on the drawings.

5. COLORCOAT (Optional)

- a. GENERAL: Work under this section will be performed by firms and/or individuals regularly engaged in that particular field. Proof will be presented to show that satisfactory results have been obtained in the past and that experienced personnel will be employed.

The Engineer shall be notified and shall inspect and approve the in-place asphalt paving prior to the application of any colorcoat or patching material.

The following paragraph only refers to courts under contract to the M-NCPPC; or when colorcoating is being applied as a design option.

Material or equipment shown on the plans or specified elsewhere as being "Supplied by Owner" will be stored at an approved MNCPPC facility. This material or equipment will become the responsibility of the contractor upon removal from the field yard, and until the completed installation is accepted by the Commission.

- b. COLORCOAT: (1) Patching: The entire court shall first be checked with both a ten-foot (10') straight edge and by flooding with water and chalk marking the outlines or any low areas. Any area showing a depression of more than one-eighth inch (1/8") shall be primed, using one part tennis court binder and three parts water. After this has dried, a patching mixture shall be applied.

Patching Mixture: 2 gallons plaster
2 gallons resurfacer
1/2 gallon tennis court binder

Note: Where manufacturer's recommended resurfacer is not available, the following patching mix will be used:

10 gallons plaster
7-1/2 gallons wearcoat
1-1/2 gallons binder

(2) Application: The color finish course shall be applied only after the surface course is thoroughly dry.

No work shall be performed when rain is imminent or when the temperature is below 50 degrees Fahrenheit or is forecasted to below 50 degrees during the twenty-four (24) hours preceding and following application.

Colorcoat should be applied with a lamb's wool rollercoater or a squeegee. Wet the roller with clear water and shake out before using. Dip rollercoater in wheelbarrow of Colorcoat mixture and apply by rolling.

(3) Finish Course: The finish course shall consist of Color Court Concrete Primer and Color Court Filler Finish or equal as approved by owner. The finish course shall not be applied until the Surface Course is thoroughly cured.

Color Court Concrete Primer shall be applied on the clean, dry underlying surface in multiple applications to obtain a total application rate of 15 to 20 gallons per 1,000 square feet of area based on the material prior to any dilution. No application shall be covered by a succeeding application until thoroughly cured.

Dilution with water to obtain proper application consistency is permitted up to a maximum of 1 part water to 2 parts Color Court Concrete Primer. The diluted material shall be homogeneous. Separation before or during application will not be permitted.

After the Color Court Concrete Primer has thoroughly cured, the entire area shall be water flooded in the presence of the Engineer and/or Landscape Architect. Any areas holding over one-sixteenth inch (1/16") depth of water shall be levelled with Color Court Concrete Primer and allowed to thoroughly cure.

The finished surface shall be smooth, free of ridges, valleys, and tool marks.

(4) Color Court Filler or Finish shall be applied to the clean, dry underlying surface in multiple applications to obtain a total application rate of 6 to 8 gallons per 1,000 sq. ft. of area, based on the material prior to any dilution. No application shall be covered by a succeeding application until thoroughly cured.

Dilution with water to obtain application consistency is permitted up to a maximum of 1 part water to 4 parts Color Court Filler or Finish. The diluted material shall be homogeneous. Segregation before or during application will not be permitted.

The finished surface shall be smooth, free from ridges, valleys and tool marks.

(5) Traffic: Protect from traffic during all operations and until opening for use. Allow the Colorcoat surface to cure at least 48 hours before allowing light foot traffic.

A minimum of four (4) days shall be allowed for the surface to cure before being opened for play.

(6) The manufacturer shall guarantee the material for one (1) year from date of acceptance against chalking, checking, fading, discoloration, or other adverse effects from ultra violet rays of the sun, from weather moisture, or from weather temperatures. The material shall be delivered to the construction site in its original unopened containers clearly labeled with the trade name and name of manufacturer.

6. PLAYING LINES

- a. Allow the Colorcoat to cure before painting lines. Line Paint (White) shall be applied only to clean surfaces.
- b. Base lines shall not be more than four inches (4") wide and playing lines not more than two inches (2") wide, accurately located and marked, and painted with a paint recommended or approved by the manufacturer of the color finish material; however, use of traffic, oil, alkyd, or solvent vehicle type paints is prohibited. The painting shall be done by skilled mechanics in a workmanlike manner in accordance with the manufacturer's standard printed instructions.
- c. Painters shall use soft soled shoes and knee pads, or kneel on boards to prevent surface indentation. Ragged and/or smeared lines will not be acceptable.

7. CHAIN LINK FENCE, PIPE AND FITTINGS GALVANIZED (Optional)

- a. **WORK INCLUDED:** The fence shall be constructed in accordance with the details as shown on the plans, and as specified herein, with new materials. All work shall be performed in a workmanlike manner satisfactory to the Commission's representative. Prior to the beginning of the work, the contractor shall locate the position of the work by marking a fence line. This line shall be inspected by the engineer before construction begins. The finished fence shall be plumb, taut, true to line and ground contour, and complete in every detail. When directed, the contractor shall be required to stake down the fence at several points between posts.
- b. **DESCRIPTION:** The fence shall be the product of a manufacturer who has demonstrated by actual installation of a similar fence that the product is of the type required. The contractor shall include all supplementary parts necessary or required for a complete and satisfactory installation within the true meaning and intent of the drawing. All runs of the fence shall present the same general appearance and the product of one manufacturer only will be accepted, except for items which do not influence the appearance of the completed fence. No used, re-rolled, or open seam steel will be permitted in posts, gates, frames, rails, or braces. A notarized certificate of American origin for the materials furnished shall be submitted to the Commission. All materials shall meet the requirements of Federal Specifications RR-F-191d and RR-F-183, as amended.
- c. **FABRIC:** The chain link fabric shall be No. 11 ASW gauge steel woven wire in two inch (2") diamond mesh or as shown on drawings varying in height as shown on plans prepared by the applicant and/or owner. The fabric shall meet the requirements of Federal Specifications FF-F-191d, except for galvanizing. The fabric shall be zinc coated by the hot dip process after weaving. The fabric shall have a knuckled salvage along the top and bottom. The weight of zinc coating on the

fabric shall be not less than 1.2 ounces per square foot of uncoated wire surface. A certificate shall be required indicating compliance with these coating requirements.

(1) Tensile Strength Test: Wire pickets of which the fence is made shall stand a tensile strength of 70,000 pounds per square inch based on a cross sectional of the galvanized wire.

(2) Galvanizing Test: Chain link fabric shall withstand six one-minute immersions under the standard Preece Test. The test is to be made on a section of wire picket at least four inches (4") in length, so as to include at least one bend and one strength side of the formed link.

d. POSTS: (1) Line Posts: Line posts shall be pipe sections not less than two inches (2") O.D. and 2.72 pounds per linear foot or two and a half inches (2-1/2") O.D. and 3.65 pounds per linear foot, as indicated on the drawings.

(2) Terminal Posts: Terminal posts (end, corner, pull, and brace posts) shall be pipe sections not less than two and one half (2-1/2") inches O.D. and 3.65 pounds per linear foot or three inches (3") O.D. and 5.79 pounds per linear foot as indicated on the drawings.

(3) Gate Posts: Gate posts shall be pipe sections not less than three inches (3") O.D. and 5.79 pounds per linear foot or four inches (4") O.D. and 9.11 pounds per linear foot as indicated on the drawings.

e. TOP RAILS: Top rails shall be hot dipped galvanized steel section of pipe not less than one and five-eighths inches (1-5/8") O.D. and 2.30 pounds per linear foot. Top rails shall be passed through the base of the line post tops and form a continuous brace from end to end of each run of fence. All couplings shall be six inches (6") long and placed every twenty feet (20') to take up expansion and contraction.

f. POST TOPS: Posts shall be fitted with heavy malleable iron or pressed steel tops. Bases of the post tops shall have flanges around the outside of the posts.

g. GATES: (1) Frames: Gate frames shall be hot-dipped galvanized steel pipe not less than one and five-eighths inches (1-5/8") O.D. and 2.27 pounds per linear foot or two inches (2") O.D. and 2.72 pounds per linear foot as indicated on the plans. The gate frames shall be provided with three-eighths inch (3/8") hot-dipped steel wires for cross bracing.

(2) Hinges: Hinges shall be high grade malleable iron of the ball and socket type, which will permit the gate to swing back against the fence. The lower hinges of the gate shall support the entire vertical load of the gate, as well as provide for the resultant horizontal reaction.

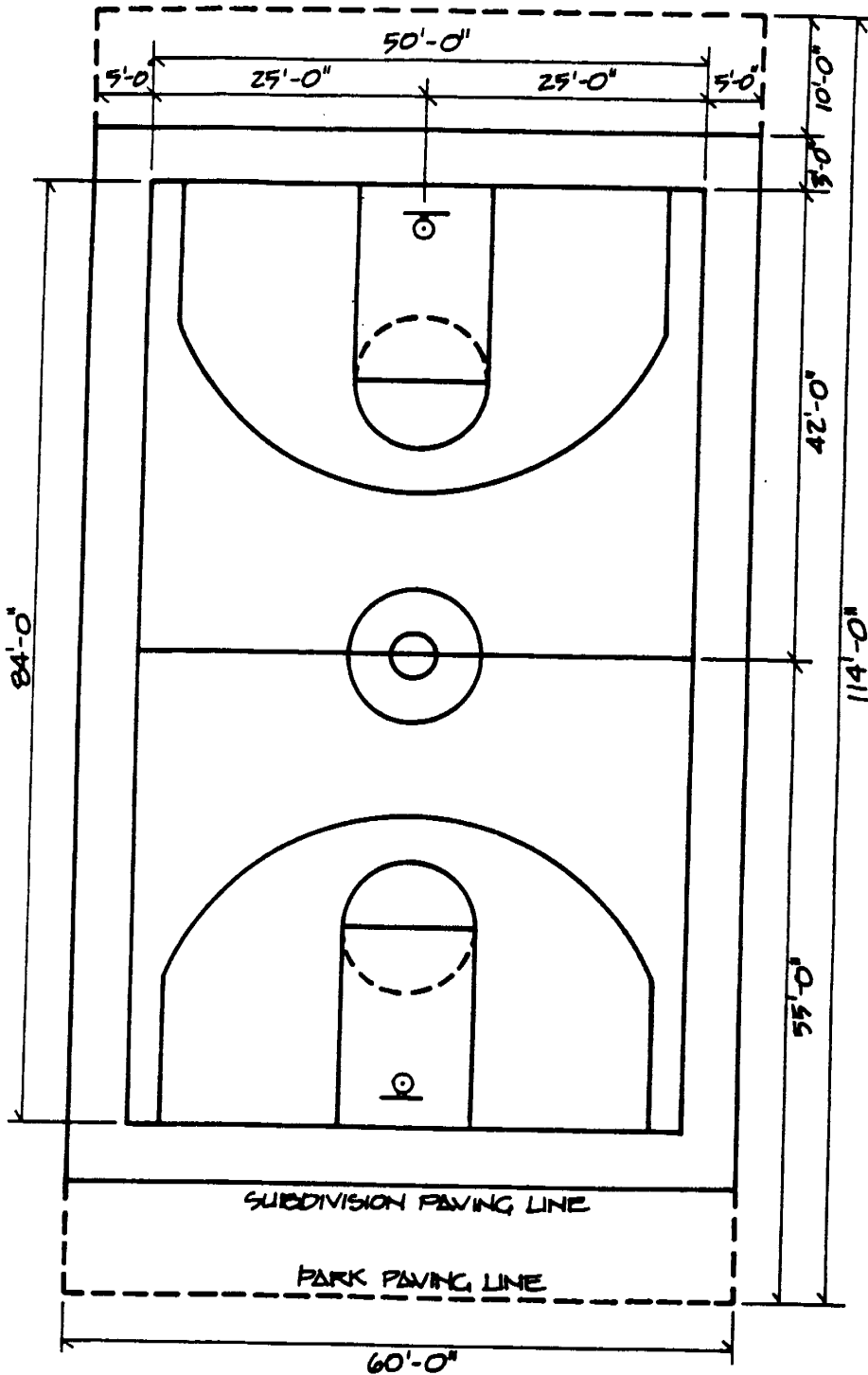

NOTES:

1. 10' RUNOUT AREA NOT TO BE OBSTRUCTED WITH DRAINAGE DITCHES, TREE FENCING, ETC.
2. RUNOUT AREA TO BE PLACED BEHIND EACH BACKSTOP.
3. POSITIVE DRAINAGE TO BE AWAY FROM COURT.
4. FULL COURT IS MIRROR IMAGE OF HALFCOURT. REFER TO HALFCOURT DETAIL # D2 FOR DIMENSIONS.
5. SEE DETAIL # D2 FOR COLORCOATING.

SCALE: 1" = 16'-0"

PLAN VIEW FULL COURT

PARKS AND RECREATION FACILITIES
GUIDELINES © MNCPPC 1983

BASKETBALL

DEPARTMENT OF PARKS & RECREATION STANDARDS & SPECIFICATIONS, Prince George's County



Date Approved: 0/3/85
James E. Feilker M. RLA #387

Drawn
MNM
CS

Date
7-83

Revised	Date

DETAIL
D1

Division of Planning, Design & Research

MARYLAND NATIONAL CAPITAL
PARK & PLANNING COMMISSION

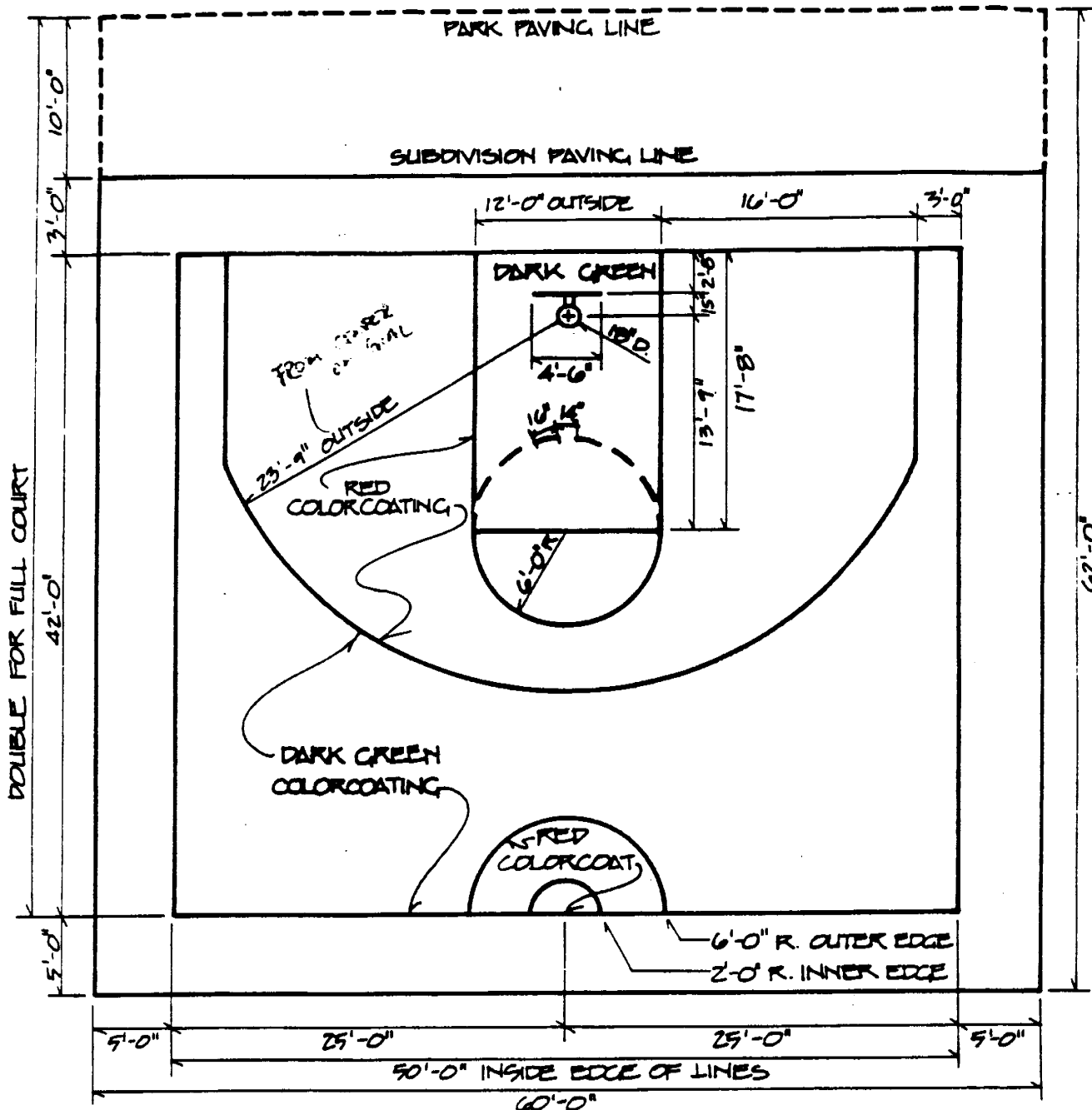

NOTES:

1. 10' RUNOUT AREA NOT TO BE OBSTRUCTED WITH DRAINAGE DITCHES, TREES, FENCING, ETC.
2. POSITIVE DRAINAGE TO BE AWAY FROM COURT.
3. ALL PLAYING LINES 2" WIDE, WHITE

4. COLORCOATING FOR FULL COURT IS MIRROR IMAGE OF HALF COURT.

PLAN VIEW HALF COURT

BASKETBALL

PARKS AND RECREATION FACILITIES
GUIDELINES © M NCPPC 1983

DEPARTMENT OF PARKS & RECREATION STANDARDS & SPECIFICATIONS, Prince George's County



Date Approved: 8/3/83

James E. Fadden Md. RLA #387

Division of Planning, Design & Research

Drawn
MNM
/CO

Date
7-83

Revised

Date

MARYLAND NATIONAL CAPITAL
PARK & PLANNING COMMISSION

DETAIL

D2

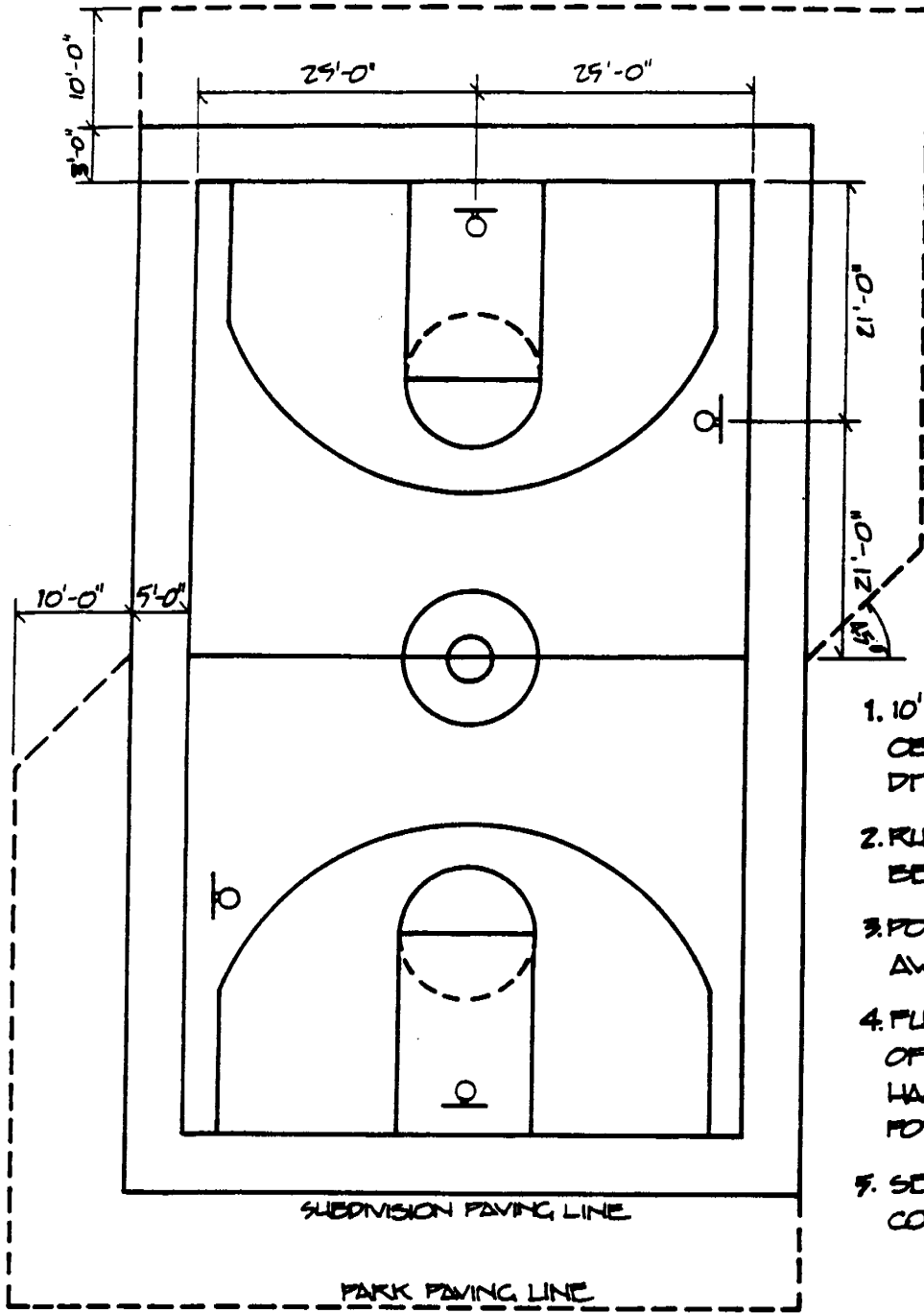

NOTES:

1. 10' RUNOUT AREA NOT TO BE OBSTRUCTED WITH DRAINAGE DITCHES, TREES, FENCING, ETC
2. RUNOUT AREA TO BE PLACED BEHIND EACH BACKSTOP.
3. POSITIVE DRAINAGE TO BE AWAY FROM COURT.
4. FULL COURT IS MIRROR IMAGE OF HALF COURT. REFER TO HALF COURT DETAIL # D2 FOR DIMENSIONS.
5. SEE DETAIL # D2 FOR COLOR COATING.

SCALE: 1" = 16'

PLAN VIEW 4 BACKSTOP

PARKS AND RECREATION FACILITIES
GUIDELINES © MNCPPC 1983

BASKETBALL

DEPARTMENT OF PARKS & RECREATION STANDARDS & SPECIFICATIONS, Prince George's County



Date Approved: 8/3/85

James E. Fuller Md. RLA #387

Division of Planning, Design & Research

Drawn
MM/M
CS

Date
7/83

Revised

Date

MARYLAND NATIONAL CAPITAL
PARK & PLANNING COMMISSION

DETAIL

D3

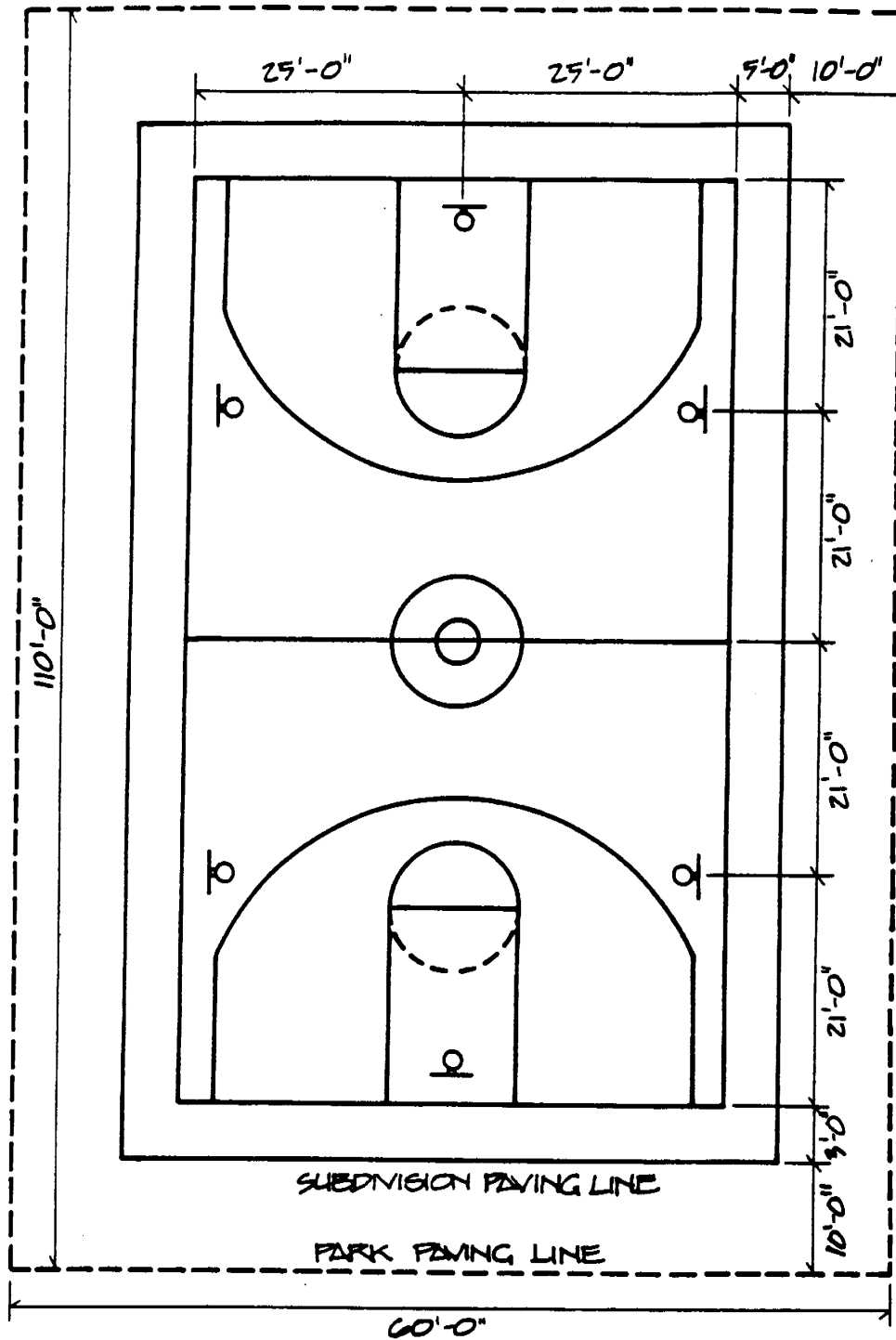

NOTES:

1. 10' RUNOUT AREA NOT TO BE OBSTRUCTED WITH DRAINAGE DITCHES, TREES, FENCING, ETC.
2. RUNOUT AREA TO BE PLACED BEHIND EACH BACKSTOP.
3. POSITIVE DRAINAGE TO BE AWAY FROM COURT
4. FULL COURT IS MIRROR IMAGE OF HALF COURT. REFER TO HALFCOURT DETAIL # D2 . DIMENSIONS.
5. SEE DETAIL # D2 FOR COLORCOATING.

SCALE: 1"=16'

PLAN VIEW & BACK BACKSTOP

PARKS AND RECREATION FACILITIES
GUIDELINES © M-NDPPC 1983

BASKETBALL

DEPARTMENT OF PARKS & RECREATION STANDARDS & SPECIFICATIONS, Prince George's County



Date Approved: 0/3/83

James E. Fuller Md. PLA #387

Division of Planning, Design & Research

Drawn
MNM
/CS

Date
7/83

Revised _____ Date _____

MARYLAND NATIONAL CAPITAL
PARK & PLANNING COMMISSION

DETAIL

D4

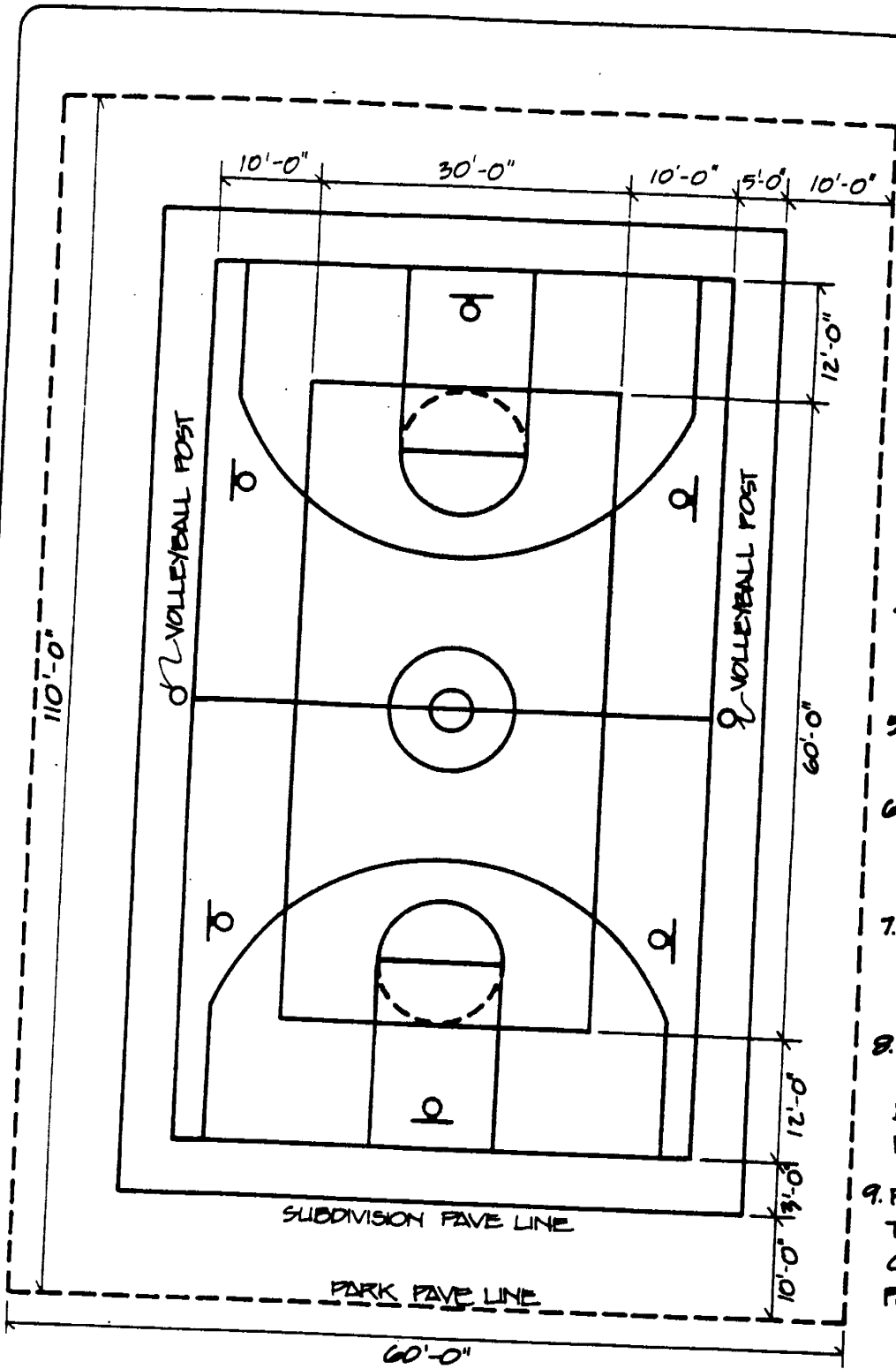

NOTES:

1. MULTI-PURPOSE COURT IS IDENTICAL TO BASKETBALL WITH THE ADDITIONAL LINE ADDED FOR VOLLEYBALL.
2. VOLLEYBALL DIFFERENT COLOR STRIPE 2" WIDE MEASURED TO INSIDE OF LINE.
3. RUNOUT AREA IS NOT TO BE OBSTRUCTED WITH DRAINAGE DITCHES, TREES, FENCING, ETC.
4. RUNOUT AREA TO BE PLACED BEHIND EACH BACKSTOP.
5. POSITIVE DRAINAGE TO BE AWAY FROM COURT.
6. REFER TO BASKETBALL HALFCOURT DETAIL #D2 FOR DIMENSIONS.
7. COURT DRAINAGE AND ORIENTATION SAME AS BASKETBALL.
8. SEE DETAIL # D2 FOR COLOR COATING DIMENSIONS (OPTIONAL FOR SUBDIVISIONS).
9. POSTS FOR VOLLEYBALL TO BE TEMPORARY AND SET OUTSIDE PAVED SURFACE FOR PLAY.

SCALE: 1" = 16'

'MULTI PURPOSE COURT

PARKS AND RECREATION FACILITIES
GUIDELINES © M-NOPPC 1983

BASKETBALL

DEPARTMENT OF PARKS & RECREATION STANDARDS & SPECIFICATIONS, Prince George's County



Date Approved: 0/3/83
James E. Fuller Md. RLA #357

Drawn MNM/CS

Date 7-83

Revised	Date

DETAIL
D5

Division of Planning, Design & Research

MARYLAND NATIONAL CAPITAL
PARK & PLANNING COMMISSION

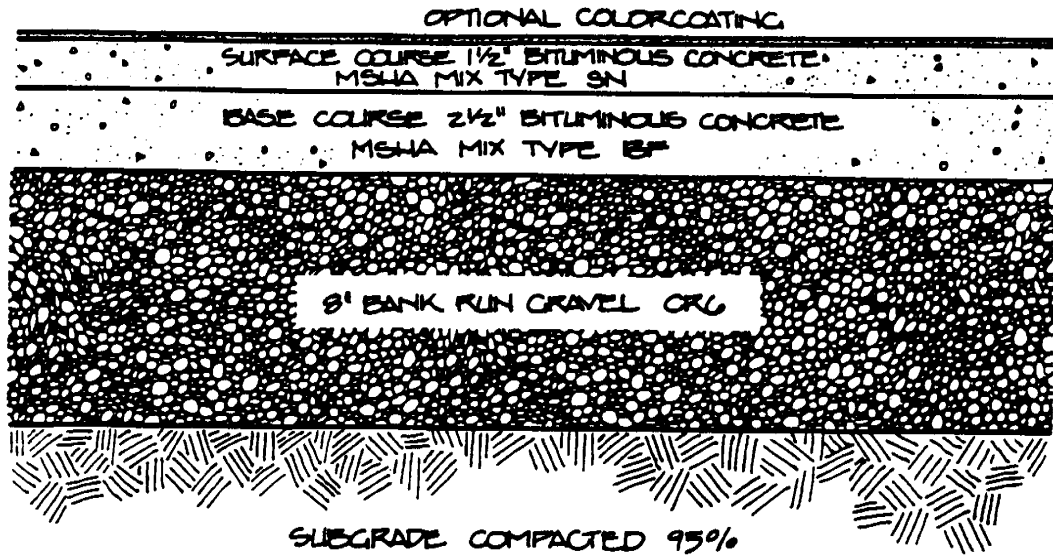

NOTES:

1. CONTRACTOR SHALL NOTIFY OWNER 24 HOURS PRIOR TO PAVING.
2. APPROVED SOIL STERILANT SHALL BE APPLIED TO SUBGRADE PRIOR TO PAVING; PROVIDE CERTIFICATION STATEMENT.
3. NOTIFY OWNER 24 HOURS PRIOR TO COLORCOATING.
 2 APPLICATIONS OF COLORCOURT® CONCRETE PRIMER FOLLOWED BY
 2 APPLICATIONS OF COLORCOURT® COLOR FILLER/FINISH

SCALE: 3/16" = 1'-0" CROSS SECTION PAVING

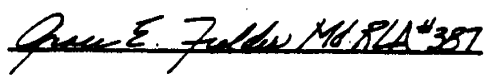
BASKETBALL					
PARKS AND RECREATION FACILITIES GUIDELINES © MNCPPC 1983					
DEPARTMENT OF PARKS & RECREATION STANDARDS & SPECIFICATIONS, Prince George's County					
	Date Approved: <u>8/3/83</u>	Drawn <i>MNM</i> <i>CS</i>	Date <u>7-83</u>	Revised _____	DETAIL D6
	 <small>MD P&LA #387</small>	MARYLAND NATIONAL CAPITAL PARK & PLANNING COMMISSION			
Division of Planning, Design & Research					

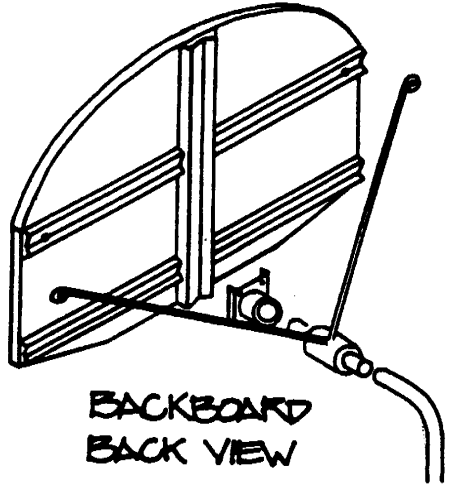
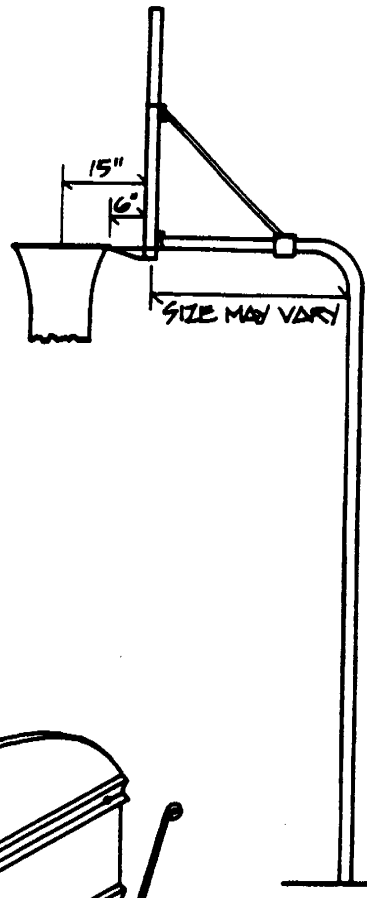
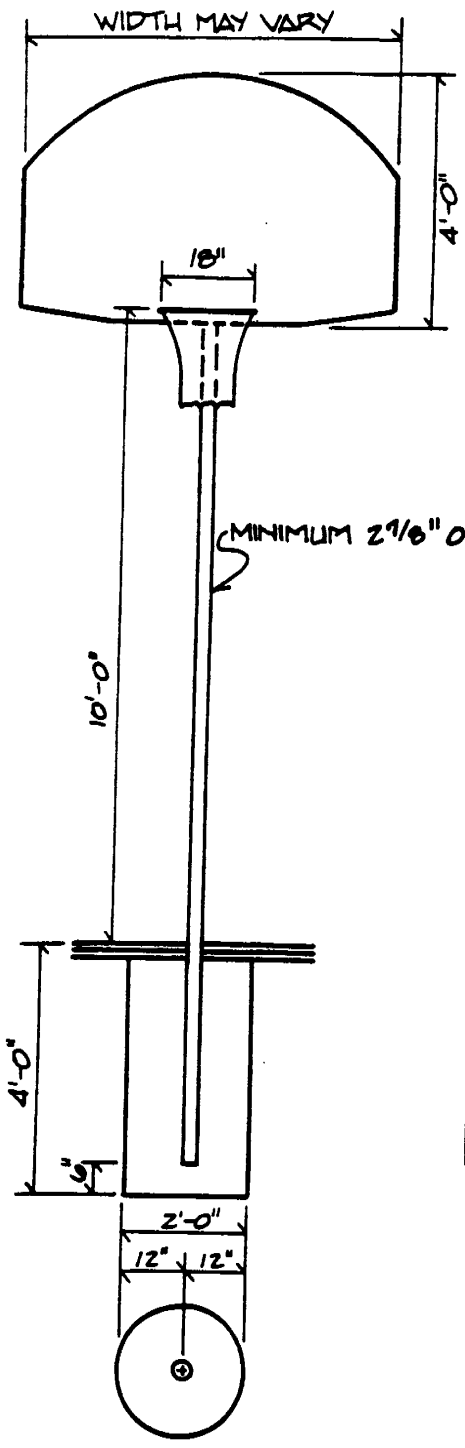

SIDE
ELEVATION

SCALE: 1" = 3'-0"

BACKBOARD

BASKETBALL

PARKS AND RECREATION FACILITIES
GUIDELINES © M-NCPPC 1983

DEPARTMENT OF PARKS & RECREATION STANDARDS & SPECIFICATIONS, Prince George's County



Date Approved: 8/3/83
James E. Fuller M.A. P.L.A. #387

Drawn
MJM/CS

Date
7-83

Revised	Date

**DETAIL
D7**

Division of Planning, Design & Research

MARYLAND NATIONAL CAPITAL
PARK & PLANNING COMMISSION

FENCE OPENING

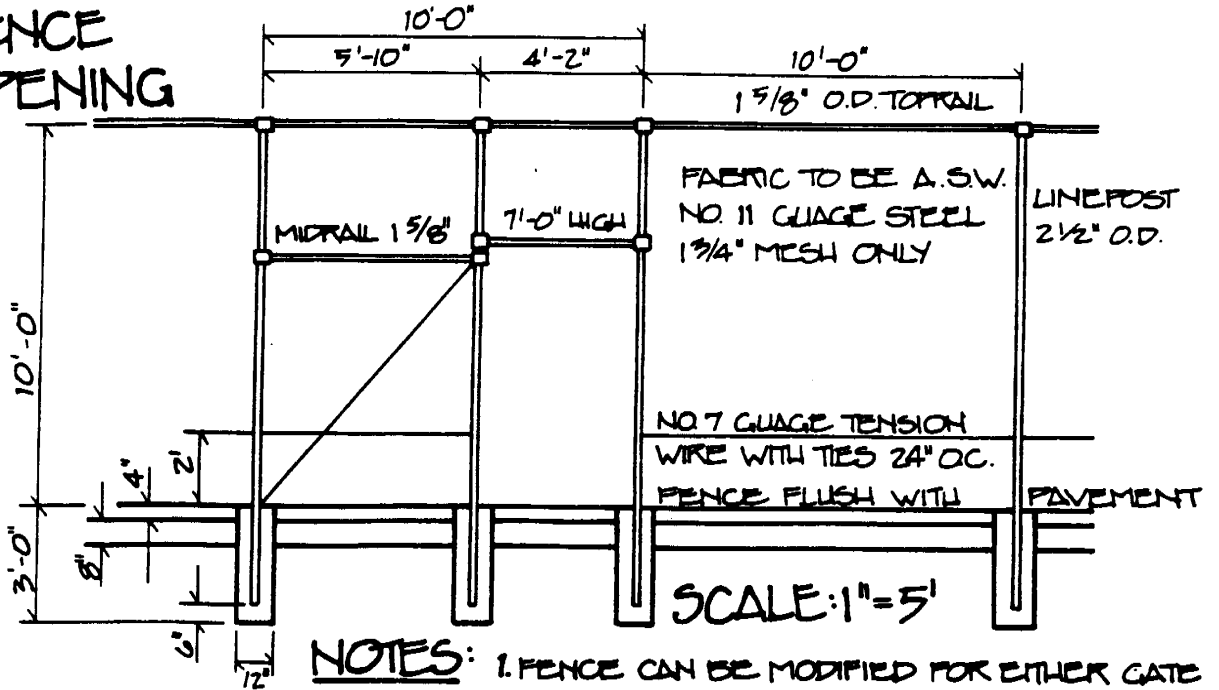

- NOTES:**
1. FENCE CAN BE MODIFIED FOR EITHER GATE OR FENCE ENTRANCE.
 2. FENCE TO BE PLACED OUTSIDE 10' RUNOUT AREA, EXTEND PAVEMENT 1' BEYOND FENCE.
 3. GATES PLACED AT SIDECORNERS OR AT END.
 4. END POSTS 3" O.D.
 5. USE 90° THREADED ELBOW OR WELD GATE CORNERS.

GATE ENTRANCE

FENCE ENTRANCE

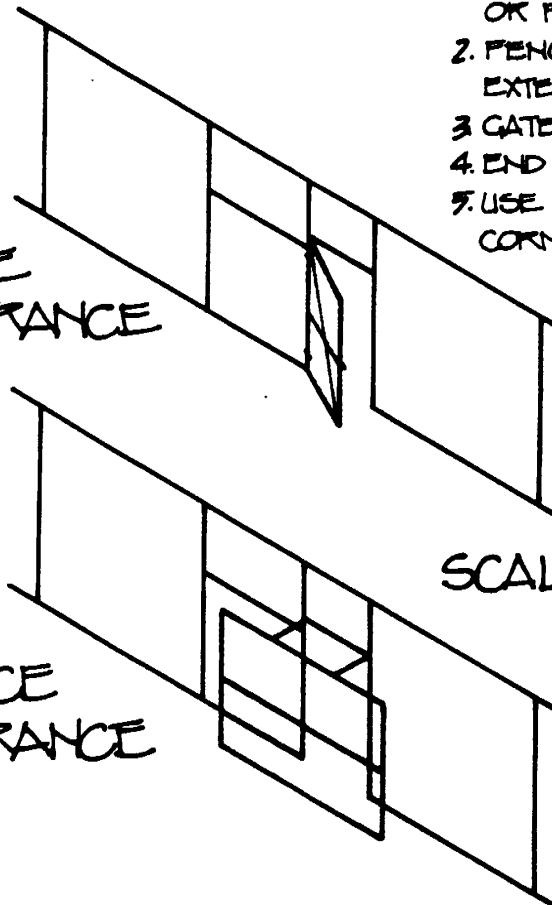

SCALE: 1" = 10'

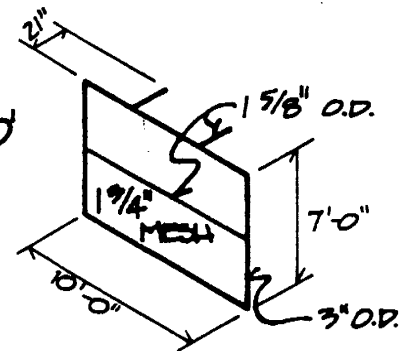
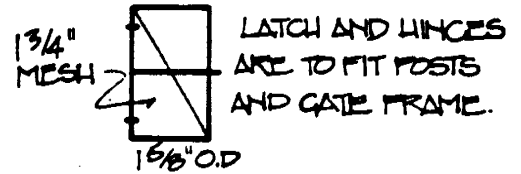

FENCING

BASKETBALL

PARIS AND RECREATION FACILITIES
GUIDELINES © M-NDPPC 1983

DEPARTMENT OF PARKS & RECREATION STANDARDS & SPECIFICATIONS, Prince Georges County



Date Approved: 8/3/83

Grace E. Fidler M.D. RLA#387

Drawn
MINI
CS

Date
7-83

Revised

Date

DETAIL

D8

FIRST PREFERENCE

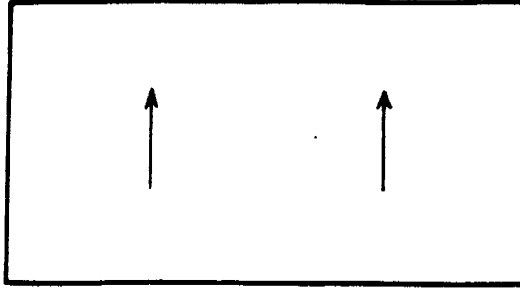

SECOND PREFERENCE

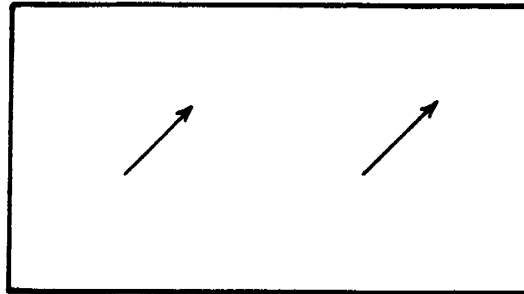

NOTES:

- 1. SLOPE ON COURTS 1%
- 2. COURTS MUST HAVE GOOD POSITIVE DRAINAGE AWAY FROM EDGES TO PREVENT EROSION.

SCALE: 1" = 40'

DRAINAGE

PARKS AND RECREATION FACILITIES
GUIDELINES © M-NEPPC 1983

BASKETBALL

DEPARTMENT OF PARKS & RECREATION STANDARDS & SPECIFICATIONS, Prince George's County



Date Approved: 8/3/83

Francis J. Zeller Md. RLA # 387

Division of Planning, Design & Research

Drawn
MNM
CS

Date

7-83

Revised

Date

MARYLAND NATIONAL CAPITAL
PARK & PLANNING COMMISSION

DETAIL

D9

(3) Miscellaneous Fittings: The gates shall be fitted with approved plunger bases, latches and provisions for padlocking. Latches, hangers and bolts shall be of the size or sizes shown on the drawings, or as directed by the Commission's representative.

- h. BRACES: Braces shall be hot-dipped and galvanized steel sections of pipe not less than one and five-eighths inches (1-5/8") O.D. and 2.27 pounds per linear foot.
The braces are to be spaced as shown on the drawings. The braces shall be securely fastened to the posts by means of malleable iron or pressed steel clamps. Bracing shall be installed horizontally and securely attached to the first line post with diagonal three-eighths inch (3/8") truss rods. Corner posts shall be braced in both directions.
 - i. POSTS, FRAMES, RAILS, AND BRACES: The post, frames, rails, and braces shall be hot-dipped galvanized steel. Federal Specifications RR-F-191d and RR-F-183, as amended.
 - j. TENSION WIRES: Tension wire of 6 gauge galvanized wire is to be stretched along the bottom of the fence and securely fastened to fabric and line posts with hog rings. The fence fabric is to be attached to the wire at intervals of approximately two feet (2').
 - k. FOOTINGS: All posts shall be set in concrete footings, as shown on drawings. Concrete shall be as specified for net posts.
1. PIPE SCHEDULE FOR FENCING

<u>Description</u>	<u>Fence Height</u>	<u>Outside Diameter</u>	<u>Weight</u>	<u>Condition</u>
Line Post	72" & Under	2" O.D.	2.72 Lbs./Ft.	Galvanized
	Over 72"	2-1/2" O.D.	3.65 " "	"
Terminal Post	72" & Under	2-1/2" O.D.	3.65 " "	"
	Over 72"	3" O.D.	5.79 " "	"
Corner Post	72" & Under	2-1/2" O.D.	3.65 " "	"
	Over 72"	3" O.D.	5.79 " "	"
Gate Post	72" & Under	3" O.D.	5.79 " "	"
	Over 72"	4" O.D.	9.10 " "	"
Top Rail		1-5/8" O.D.	2.27 " "	"

- m. FENCING INDICATED ON PLANS TO HAVE BARBED WIRE AND V-BAR BRACING SHALL BE CONSTRUCTED OF THE FOLLOWING MATERIAL:

<u>Description</u>	<u>Fence Height</u>	<u>Outside Diameter</u>	<u>Weight</u>	<u>Condition</u>
Line Post	72" & Over	2-1/2" O.D.	3.65 Lbs/Ft.	Galvanized
Terminal Post	72" & Over	3" O.D.	5.79 " "	"

- n. FENCING: The fencing wire shall not be installed until the 1" surface course is completed, and it shall not be installed before colorcoating is started. Where this is impossible and wire fence must be installed after the resurfacers is on, boards will be used under all ladders and wire to protect the court from indentation.

TENNIS COURT(S)

Tennis Court(s) are an excellent base for a central recreation area from which other activities can be spun off. When sited in conjunction with playground(s), picnic area(s), and open play area(s) group activities occur that create a sense of neighborhood.

A tennis court is to be provided at the rate of 1 per 1,000 persons in a proposed subdivision. The population of the subdivision is based on a per unit figure from the Department of Planning, multiplied by the proposed number of dwelling units.

Unit type X persons/unit type=projected population

A tennis court may be sited singularly or in conjunction with other facilities in order to form a central recreation area. The tennis court are to be sited so as to have direct access from a hard surfaced path.

DESIGN REQUIREMENTS

1. Required

1 - 60'x122' tennis court per 1,000 persons.

2. Size

Single Court - 60'x122' (includes apron) (Detail ~~E1~~
Double Court - 110'x122' (includes apron) (Detail ~~E2~~

3. Orientation

The majority of tennis is played in this area in spring, summer, and fall. During this time, the sun is west or 20 degrees north of west. The most desirable orientation to benefit the greatest number of players is directly north and south. In extremely difficult siting situations, the courts maybe rotated to 15° northeast.

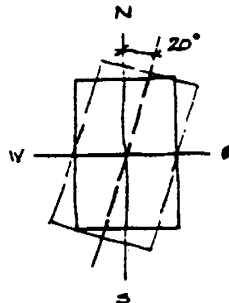

ORIENTATION

ILLUSTRATION # 9.1

Tennis Courts are not to be sited in, on, or under any of the following:

- a. 100 year floodplain;
- b. Utility lines or easements;
- c. Areas that are to be utilized as sediment control ponds;

- d. Within 25' of parking lot, property or lot lines;
- e. Within 40' of access drive or road;
- f. At bottoms of drainage courses.

5. Compaction: 95% see design specifications

6. Drainage (Detail **E5**)

Maximum 1% slope in any direction. Spot elevations to be shown on site development plan in all four corners and center court line.

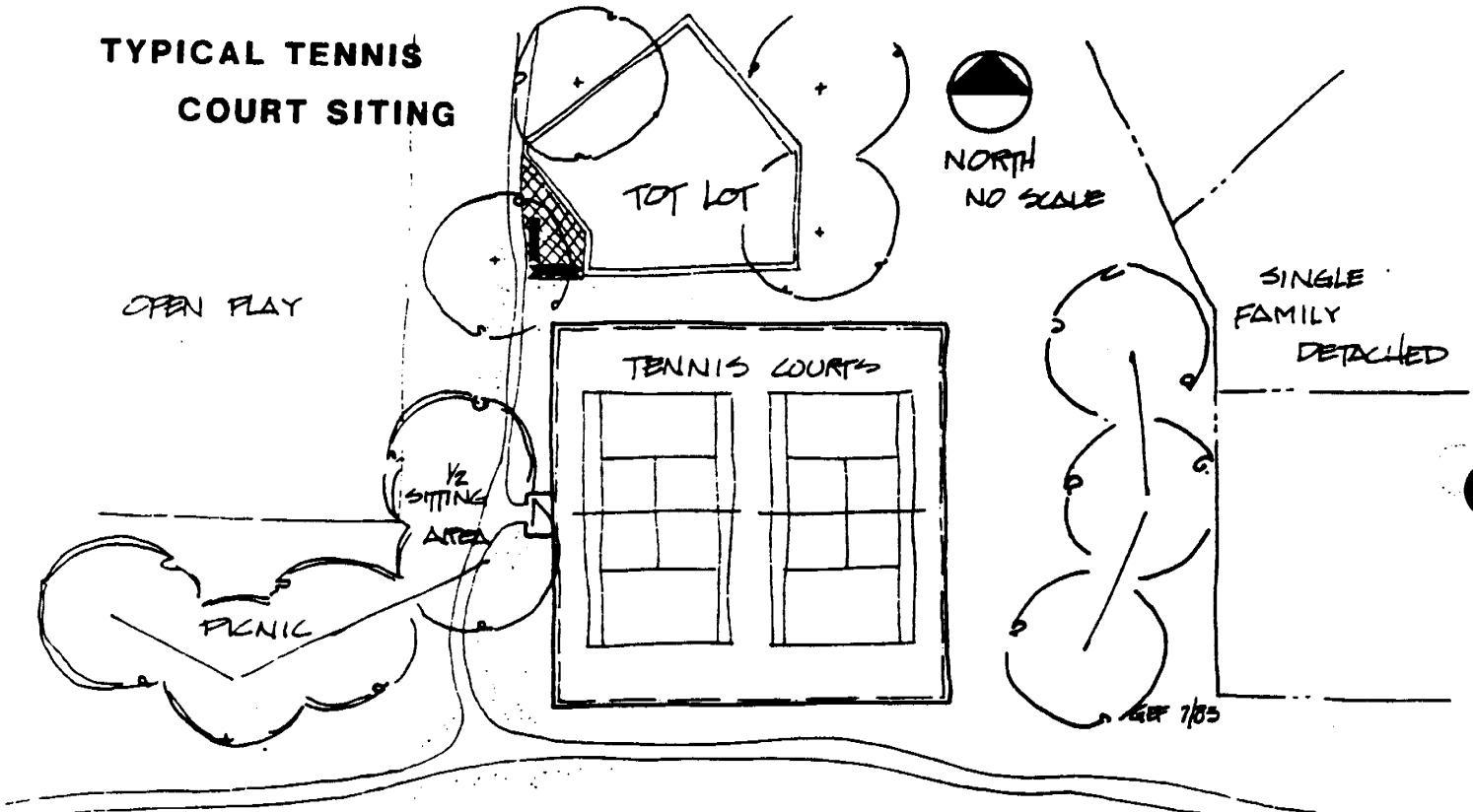

ILLUSTRATION # 9.2

Occasionally it will be necessary to deviate from the preferred drainage patterns, however, the courts must still meet all the above requirements for orientation, compaction, drainage, siting, etc.

7. Fencing (Detail **E4**)

All courts are to be fenced with ten (10') foot high chain link fence. Entrances to the court or courts are to be provided at center court, this will allow entrance on an off the court with a minimum amount of disturbance to play. See detail numbers and written specifications.

8. Buffering

No buffering of tennis courts will be required unless the court(s) is sited in such a way as to be unsightly from adjoining homes. Meeting minimum setbacks will assure no need to buffer.

DESIGN OPTIONS

Suggested Additions to Improve Facility

Shading

If tennis courts are planned for an area to be cleared of all existing trees, a shaded area should be provided for player rest and spectator comfort. Shade may be provided by shade trees such as willow oaks and locust that are low in trash, or by vinyl or redwood strips through chain link fence. Minimal shade will be provided by vinyl and redwood strips. A hooded viewing stand will provide shade.

Seating

1 - 6' permanent bench should be provided for each court.

The bench should be located in an area that will allow view of play on the courts in addition to shade from the heat of the late morning to mid-afternoon sun.

PLAN REQUIREMENTS

Written Specifications & Construction Details (Detail #E3 for cross sections)

Written specifications and construction details are provided for the construction of the tennis courts. All courts are to be constructed in accordance with these specifications. The subdivider and/or his designer will find it necessary to occasionally modify the specifications slightly for a particular site. The Department of Parks and Recreation has used these specifications and construction details to build hundreds of tennis courts in the past 15 years, and has modified them to fit the soils of Prince George's County, Maryland.

Preliminary Plat and Comprehensive Design Plan Requirements

The preliminary plat is to show the location of tennis courts and their relationship to paths, property lines, parking, and other recreational facilities.

Site Plan and Specific Design Plan Requirements

Site Development Plan is to contain:

1. Site grading
2. Spot elevations
3. Landscaping
4. Paths
5. Buffering and landscaping
6. Setback lines
7. Seating

Detail Sheet Requirements

1. Layout
2. Fencing
3. Entrances
4. Written specifications
5. Cross sections

CONSTRUCTION SPECIFICATIONS

1. GENERAL REQUIREMENTS

- a. **SCOPE OF WORK TO BE DONE:** The contract work to be performed under this section consists of furnishing all of the required labor, materials, equipment, implements, parts, and supplies necessary for, or appurtenant to, the installation of tennis multi-purpose court(s), in accordance with the drawings and as further elaborated in these specifications.
- b. **STANDARDS:** The work hereunder shall be done in a thorough workmanlike manner. Any reference to a specification or designation of the American Society for Testing and Materials, Federal Specifications, or other standards, codes, or orders refers to the most recent or latest specification or designation. Where names of specific products may be designated in these specifications or in the details appearing on the drawings, the intent is to state the general type and quality of product desired without ruling out the use of other products of equal type and quality, provided that use of such other products of equal type and quality has been approved in writing by the owner or his representative with prior approval from the Department of Parks and Recreation.
- c. **LAYOUT OF WORK:** The work shall be laid out to true lines and grades in full accordance with the drawings. Surveying of lines and grades, from a base line and bench mark established by the owner at the construction site, and staking therefor shall be accomplished by the Contractor. Monuments shall be substantially established, protected, and maintained in place by the Contractor for the duration of the contract or until such other time as their removal may be authorized by the Owner or his representative.
- d. **CLEARING AND GRUBBING:** Trees and other vegetation, including their root systems to a depth of not less than twelve inches (12"), shall be removed from the site and the soil treated with a sterilant that will effectively inhibit future growth of flora. Sterilant is to be approved by the Engineer and limited to use beneath areas to be paved.

2. FILL AND COMPACTION

- a. **MATERIALS:** (1) All borrow materials used in earth fill or backfill must meet the following specifications and may be rejected on visual inspection pending testing and samples. Fill and backfill materials shall be a well graded combination of granular materials and silt clay soil. Materials shall have no more than 70 percent passing #4 sieve, and no more than 10 percent #200 sieve. No gravel or stone shall be larger than 1/3 the depth of the layer to be placed.

Minimum Class II fill required in all areas to be paved or that have footings Class III fill may be utilized in grass areas with a minimum of 12" cover.

Soil shall have a liquid limit, as determined by current AASHTO Standard Methods of "Determining the Liquid of Soils" T89, of not greater than 40 and a plasticity index as determined by current AASHTO Standard Methods of Calculating the Plasticity Index of Soils of not more than 10. Material to be used shall be free from trash, brick, broken concrete, tree roots, sod, ashes, or cinders.

(2) Samples shall be submitted at least one week in advance of desired date of approval. Acceptance of material from any location shall be construed as approval of entire location only insofar as material continues to meet these specifications.

(3) Materials from this site shall be deemed satisfactory only insofar as they conform to this section on the specifications.

- b. **FILL AND BACKFILL CONSTRUCTION:** Wherever the term "Maximum dry density" is used, it shall be determined in accordance with AASHTO Designation T-99 Field Determination of Density of Soils in Place, Sand Method.

Materials prescribed herein for fill and backfill shall be deposited in uniform layers not to exceed eight inches in thickness, loose measurements, and each layer shall be compacted, to not less than 95 percent at maximum dry density. Material shall be placed at a moisture content approximately equal to optimum.

- c. **DRAINAGE:** Keep excavations free from water. Where subgrade is wet contractor shall take whatever steps are necessary to drain and dry out to optimum moisture contents, including ditching, drain tiles, and pumping at no cost to Owner.
- d. **SUBGRADE PREPARATION:** Subgrade shall be compacted so that it is firm, hard, and unyielding. It shall be compacted to 95% of dry weight density as determined by AASHTO Designation T-99 Method A. After compaction, it shall be true to lines and grades as set forth in the plans. After final rolling, the subgrade shall be tested with a ten (10) foot straight edge laid parallel with the sides of the pavement and any depressions or high spots exceeding normal tolerances shall be corrected.

All soft and unstable material and any other portions of the subgrade which will not properly compact, or serve the purpose intended, shall be removed and disposed of and replaced with material approved by the Engineer.

The Engineer shall be notified and shall inspect and approve the sub-base prior to any paving.

3. BITUMINOUS SURFACING

- a. GENERAL: In general, all work performed under this item shall be in accordance with Item 42 of the Prince George's County General Specifications and Standards for Highway and Street Construction dated July, 1965, or its updated version.
- b. BASE COURSE: Compacted bituminous surfacing material shall be as detailed on the drawings prepared by the applicant. A careful check shall be made to insure that a complete bond is made between each pour. All areas exceeding a tolerance of 3/8 inch, with a ten (10) foot straight edge, at the time of the pour, shall be repaired immediately and brought to the required elevation. The entire area shall be carefully checked immediately after placing the bituminous concrete and thoroughly rolled. Rolling shall be accomplished in both directions and all wheel and roller marks, etc., shall be thoroughly rolled and removed. Samples of the finished mix shall be tested to determine gradation, and asphalt cement content.

Note: Asphaltic concrete mixtures shall not be placed or spread when the base or supporting course is damp or when other weather conditions prevent proper spreading, finishing, or compaction. A tack coat of Ae-4 or RC-250 in the amount of .05 gallons per square yard shall be applied to the top of the base and binder courses prior to placing the surface course. Tack coat may not be required if base and/or binder course is freshly placed and thoroughly clean.

- c. SURFACE COURSE: One (1) inch of compacted bituminous surfacing material, as detailed on drawings, shall be spread over the entire area utilizing a self-propelled bituminous paving machine. The spreading shall be brought up to a true and even surface at the proposed finished grade. A careful check shall be made to insure a complete bond is made between each pour. All areas exceeding a tolerance of 1/8 inch with a ten (10) foot straight edge, at the time of the pour, shall be repaired immediately and brought to the required elevation. The entire area shall be carefully checked immediately after placing the bituminous concrete and thoroughly rolled. Rolling shall be accomplished in both directions and all wheel and roller marks, etc., shall be thoroughly rolled and removed. Samples of the finished mix shall be tested to determine gradation, and asphalt cement content.

4. POST AND FOUNDATIONS

- a. CONCRETE: Concrete for foundations shall be mixed in ratios of not less than four and one half (4-1/2) standard 94-pound sacks of cement per cubic yard of concrete, with one (1) such sack of cement to not more than a compressive strength of not less than two thousand five hundred (2,500) pounds per square inch at the twenty-eighth (28th) day after pouring. Foundations shall be as indicated on the drawings.
- b. TENNIS NET POSTS AND SLEEVES: Net posts shall be galvanized steel having an outside diameter of not less than three inches and shall be equipped with lever or ratchet-type net tightening devices for

nonmetallic nets. Posts and sleeves therefore shall be set where indicated on drawings. Posts shall be set as indicated on the drawings so as to support the net at a height of forty-two inches (42") above the court surface at the new posts.

Tennis net posts shall be set in 3-1/2" O.D. pipe sleeves, located and set in concrete as per the drawings. Tops of sleeves shall be flush with the final finished surface of the courts.

- c. CENTER STRAP ANCHOR: A center anchor shall be positioned as shown on the drawings and set in concrete footings.

5. COLORCOAT

- a. GENERAL: Work under this section shall be performed by firms and/or individuals regularly engaged in the particular field. Proof will be presented to show that satisfactory results have been obtained in the past and that experienced personnel will be employed.

The Engineer shall be notified and shall inspect and approve the in-place asphalt paving prior to the application of any colorcoat or patching material.

The following paragraph refers only to courts under contract to the M-NCPPC.

Material or equipment shown on the plans or specified elsewhere as being "Supplied by Owner" will be stored at the Calvert Road Maintenance Yard located at 5800 Calvert Road, College Park, Maryland. This material or equipment will become the responsibility of the Contractor upon removal from the field yard, and until the completed installation is accepted by the Commission.

- b. COLORCOAT: (1) Patching: The entire court shall first be checked with both a ten foot (10') straight edge and by flooding with water and chalk marking the outlines or any low areas. Any area showing a depression of more than one-eighth inch (1/8") shall be primed, using one part tennis court binder and three parts water. After this has dried, a patching mixture shall be applied.

Patching Mixture: 2 gallons plaster
2 gallons resurfacer
1/2 gallon tennis court binder

Note: Where manufacturer's recommended resurfacer is not available, the following patching mix shall be used:

10 gallons plaster
7-1/2 gallons wearcoat
1-1/2 gallons binder

(2) Application: The color finish course shall be applied only after the surface course is thoroughly dry.

No work shall be performed when rain is imminent or when the temperature is below 50 degrees Fahrenheit or is forecasted to below 50 degrees during the twenty-four (24) hours preceding and following application.

Colorcoat should be applied with a lamb's wool rollercoater or a squeegee. Wet the roller with clear water and shake out before using. Dip rollercoater in wheelbarrow of Colorcoat mixture and apply by rolling.

(3) Finish Course: The finish course shall consist of Color Court Concrete Primer and Color Court Filler Finish or equal as approved by owner. The finish course shall not be applied until the Surface Course is thoroughly cured.

Color Court Concrete Primer shall be applied on the clean, dry underlying surface in multiple applications to obtain a total application rate of 15 to 20 gallons per 1,000 sq. ft. of area based on the material prior to any dilution. No application shall be covered by a succeeding application until thoroughly cured.

Dilution with water to obtain proper application consistency is permitted up to a maximum of 1 part water to 2 parts Color Court Concrete Primer. The diluted material shall be homogeneous. Separation before or during application will not be permitted.

After the Color Court Concrete Primer has thoroughly cured, the entire area shall be water flooded in the presence of the Engineer. Any areas holding over one-sixteenth inch (1/16") depth of water shall be levelled with Color Court Concrete Primer and allowed to thoroughly cure.

The finished surface shall be smooth, free of ridges, valleys, and tool marks.

(4) Color Court Filler or Finish shall be applied to the clean, dry underlying surface in multiple applications to obtain a total application rate of 6 to 8 gallons per 1,000 sq. ft. of area, based on the material prior to any dilution. No application shall be covered by a succeeding application until thoroughly cured.

Dilution with water to obtain application consistency is permitted up to a maximum of 1 part water to 4 parts Color Court Filler or Finish. The diluted material shall be homogeneous. Segregation before or during application will not be permitted.

The finished surface shall be smooth, free from ridges, valleys and tool marks.

(5) Traffic: Protect from traffic during all operations and until opening for use. Allow the Colorcoat surface to cure at least 48 hours before allowing light foot traffic.

A minimum of four (4) days shall be allowed for the surface to cure before being opened for play.

(6) The manufacturer shall guarantee the material for one (1) year from date of acceptance against chalking, checking, fading, discoloration, or other adverse effects from ultra violet rays of the sun, from weather moisture, or from weather temperatures. The material shall be delivered to the construction site in its original unopened containers clearly labeled with trade name and name of manufacturer.

6. PLAYING LINES

- a. Allow the Colorcoat to cure before painting lines. Line paint (white) shall be applied only to clean surfaces.
- b. Base lines shall not be more than four inches (4") wide and playing lines not more than two inches (2") wide, accurately located and marked, and painted with a paint recommended or approved by the manufacturer of the color finish material; however, use of traffic, oil, alkyd, or solvent vehicle type paints is prohibited. The painting shall be done by skilled mechanics in a workmanlike manner in accordance with the manufacturer's standard printed instructions.
- c. Painters shall use soft-soled shoes and knee-pads, or kneel on boards to prevent surface indentation. Ragged and/or smeared lines will not be acceptable.

7. CHAIN LINK FENCE, GALVANIZED PIPE, AND GALVANIZED FITTINGS

- a. **WORK INCLUDED:** The fence shall be constructed in accordance with the details as shown on the plans, and as specified herein, with new materials. All work shall be performed in a workmanlike manner which is satisfactory to the Commission's representative. Prior to the beginning of the work, the Contractor shall locate the position of the work by marking a fence line. This line shall be inspected by the Engineer before construction begins. The finished fence shall be plumb, taut, true to line and ground contour, and complete in every detail. When directed, the Contractor shall be required to stake down the fence at several points between posts.
- b. **DESCRIPTION:** The fence shall be the product of a manufacturer who has demonstrated by actual installation of a similar nature that its product is of the type required. The Contractor shall include all supplementary parts necessary or required for a complete and satisfactory installation within the true meaning and intent of the drawing. All runs of the fence shall present the same general appearance and the product of one manufacturer only will be accepted, except for items which do not influence the appearance of the completed fence. No used, re-rolled or open seam steel will be permitted in posts, gates, frames, rails, or braces. A notarized certificate of American

origin for the materials furnished shall be submitted to the Commission. All materials shall meet the requirements of Federal Specifications RR-F-191d and RR-F-183 as amended.

- c. FABRIC: The chain link fabric shall be No. 11 ASW gauge steel woven wire in 2-inch diamond mesh or as shown on drawings varying in height, as shown on plans prepared by the applicant. The fabric shall meet the requirements of Federal Specifications FF-F-191d, except for galvanizing. The fabric shall be zinc coated by the hot dip process after weaving. The fabric shall have a knuckled selvage along the top and bottom. The weight of zinc coating on the fabric shall be not less than 1.2 ounces per square foot of uncoated wire surface. A certificate shall be required indicating compliance with these coating requirements.

(2) Tensile Strength Test: Wire pickets of which the fence is made shall stand a tensile strength of 70,000 pounds per square inch based on a cross section of the galvanized wire.

(3) Galvanizing Test: Chain link fabric shall withstand six one-minute immersions under the standard Preece Test. The test is to be made on a section of wire picket at least four inches (4) in length, so as to include at least one bend and one strength side of the formed link.

- d. POSTS: (1) Line Posts: Line posts shall be pipe sections not less than 2 inches O.D. and 2.72 pounds per linear foot or 2-1/2 inches O.D. and 3.65 pounds per linear foot, as indicated on the drawings.
- (2) Terminal Posts: Terminal posts (end, corner, pull, and brace posts) shall be pipe sections not less than 2-1/2 inches O.D. and 3.65 pounds per linear foot or 3 inches O.D. and 5.79 pounds per linear foot, as indicated on the drawings.
- (3) Gate Posts: Gate posts shall be pipe sections not less than 3 inches O.D. and 5.79 pounds per linear foot or 4 inches O.D. and 9.11 pounds per linear foot, as indicated on the drawings.
- e. TOP RAILS: Top rails shall be hot dipped galvanized steel sections of pipe not less than 1-5/8 inches O.D. and 2.30 pounds per linear foot. Top rails shall be passed through the base of the line post tops and form a continuous brace from end to end of each run of fence. All couplings shall be 6 inches long and placed every 20 feet to take up expansion and contraction.
- f. POST TOPS: Posts shall be fitted with heavy malleable iron or pressed steel tops. Bases of the post tops shall have flanges around the outside of the posts.
- g. GATES: (1) Frames: Gate frames shall be hot-dipped galvanized steel pipe not less than 1-5/8 inches O.D. and 2.27 pounds per linear foot or 2 inches O.D. and 2.72 pounds per linear foot, as indicated on the plans. The gate frames shall be provided with 3/8-inch hot-dipped steel wires for cross bracing.

(2) Hinges: Hinges shall be high grade malleable iron of the ball and socket type, which will permit the gate to swing back against the fence. The lower hinges of the gate shall support the entire vertical load of the gate, as well as provide for the resultant horizontal reaction.

(3) Miscellaneous Fittings: The gates shall be fitted with approved plunger bases, latches, and provisions for padlocking. Latches, hangers and bolts shall be of the size or sizes shown on the drawings, or as directed by the Commission's representative.

- h. BRACES: Braces shall be hot-dipped and galvanized steel sections of pipe not less than 1-5/8 inches O.D. and 2.27 pounds per linear foot. The braces are to be spaced as shown on the drawings. The braces shall be securely fastened to the posts by means of malleable iron or pressed steel clamps. Bracing shall be installed horizontally and securely attached to the first line post with diagonal 3/8-inch truss rods. Corner posts shall be braced in both directions.
- i. POSTS, FRAMES, RAILS, AND BRACES: The post, frames, rails, and braces shall be hot-dipped galvanized steel, Federal Specifications RR-F-191d and RR-F-183, as amended.
- j. TENSION WIRES: Tension wire of 6 gauge galvanized wire shall be stretched along the bottom of the fence and securely fastened to fabric and line posts with hog rings. The fence fabric is to be attached to the wire at intervals of approximately two (2') feet.
- k. FOOTINGS: All posts shall be set in concrete footings, as shown on drawings. Concrete, as previously specified for net posts is to be used for footings.

1. PIPE SCHEDULE FOR FENCING

<u>Description</u>	<u>Fence Height</u>	<u>Outside Diameter</u>	<u>Weight</u>	<u>Condition</u>
Line Post	72" & Under	2" O.D.	2.72 Lbs./Ft.	Galvanized
	Over 72"	2-1/2" O.D.	3.65 " "	"
Terminal Post	72" & Under	2-1/2" O.D.	3.65 " "	"
	Over 72"	3" O.D.	5.79 " "	"
Corner Post	72" & Under	2-1/2" O.D.	3.65 " "	"
	Over 72"	3" O.D.	5.79 " "	"
Gate Post	72" & Under	3" O.D.	5.79 " "	"
	Over 72"	4" O.D.	9.10 " "	"
Top Rail		1-5/8" O.D.	2.27 " "	"

- m. THAT FENCING INDICATED TO HAVE BARBED WIRE AND V-BAR BRACING SHALL BE CONSTRUCTED OF THE FOLLOWING MATERIAL:

<u>Description</u>	<u>Fence Height</u>	<u>Outside Diameter</u>	<u>Weight</u>	<u>Condition</u>
Line Post	72" & Over	2-1/2" O.D.	3.65 Lbs/Ft.	Galvanized
Terminal Post	72" & Over	3" O.D.	5.79 " "	"

- n. FENCING: The fencing wire shall not be installed until the 1" surface course is completed, and it shall be installed before colorcoating is started. Where this is impossible and wire fence must be installed after the resurfacers is on, boards will be used under all ladders and wire to protect the court from indentation.

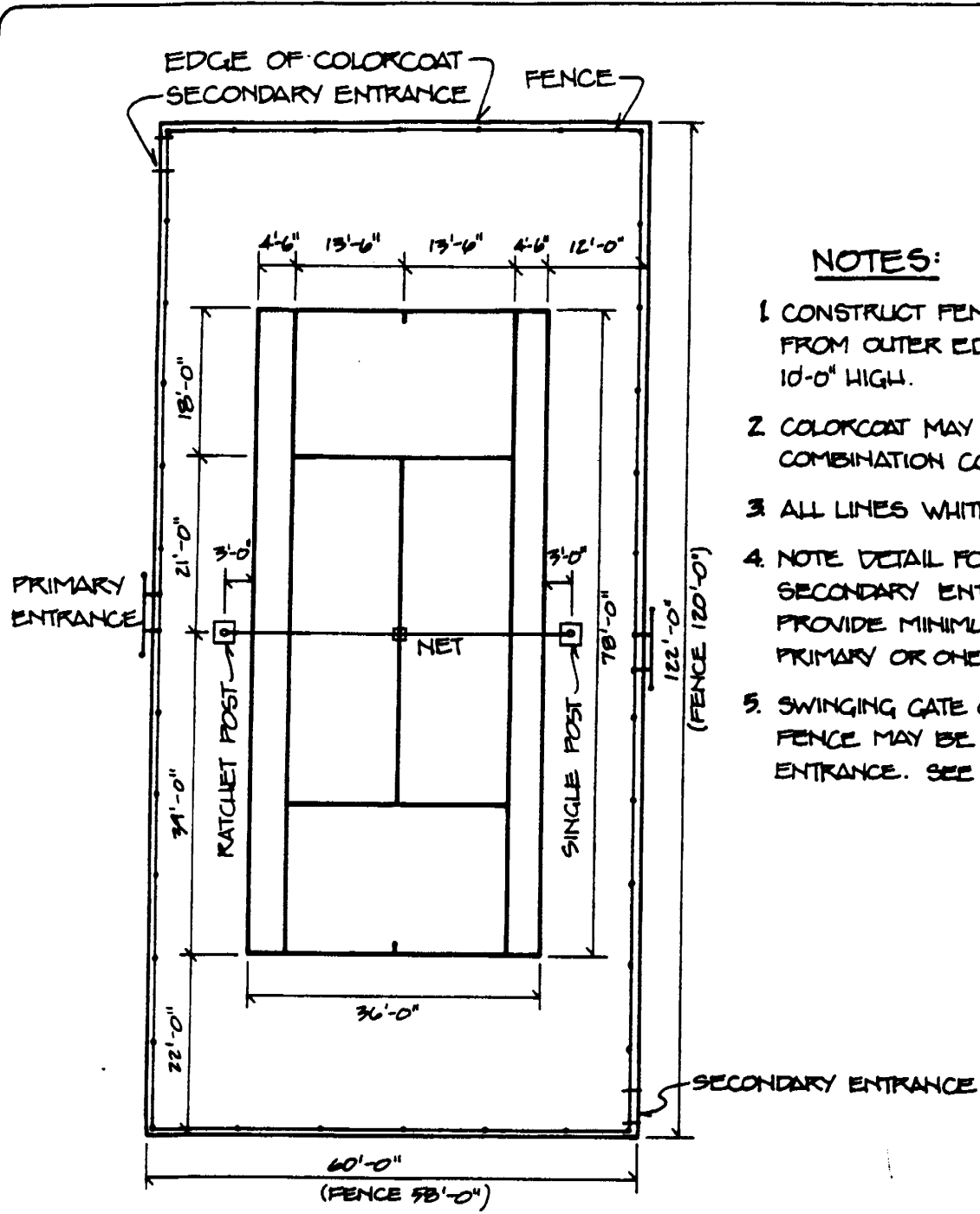

NOTES:

1. CONSTRUCT FENCE ONE FOOT FROM OUTER EDGE OF COURT 10'-0" HIGH.
2. COLORCOAT MAY BE GREEN OR COMBINATION COLORS.
3. ALL LINES WHITE 2" WIDE.
4. NOTE DETAIL FOR PRIMARY AND SECONDARY ENTRANCE LOCATIONS PROVIDE MINIMUM OF ONE PRIMARY OR ONE SECONDARY.
5. SWINGING GATE OR SETBACK FENCE MAY BE USED FOR ENTRANCE. SEE DETAIL #EA.

SCALE: 1" = 20' **PLAN VIEW SINGLE COURT**

<p>TENNIS</p> <p><small>PARKS AND RECREATION FACILITIES GUIDELINES P-M-NCPPC 1983</small></p> <p><small>DEPARTMENT OF PARKS & RECREATION STANDARDS & SPECIFICATIONS, Prince George's County</small></p>		<p>DETAIL</p> <p>E1</p>						
<p>MNC P&PC</p>	<p>Date Approved: <u>8/3/83</u></p> <p><u>James E. Fielder MD, PLA #387</u></p> <p><small>Division of Planning, Design & Research</small></p>	<p>Drawn <u>MNY/CS</u></p>	<p>Date <u>7-83</u></p>	<table border="1" style="width: 100%; border-collapse: collapse;"> <tr> <th style="width: 25%;">Revised</th> <th style="width: 25%;">Date</th> </tr> <tr> <td> </td> <td> </td> </tr> </table>	Revised	Date		
Revised	Date							
<p><small>MARYLAND NATIONAL CAPITAL PARK & PLANNING COMMISSION</small></p>								

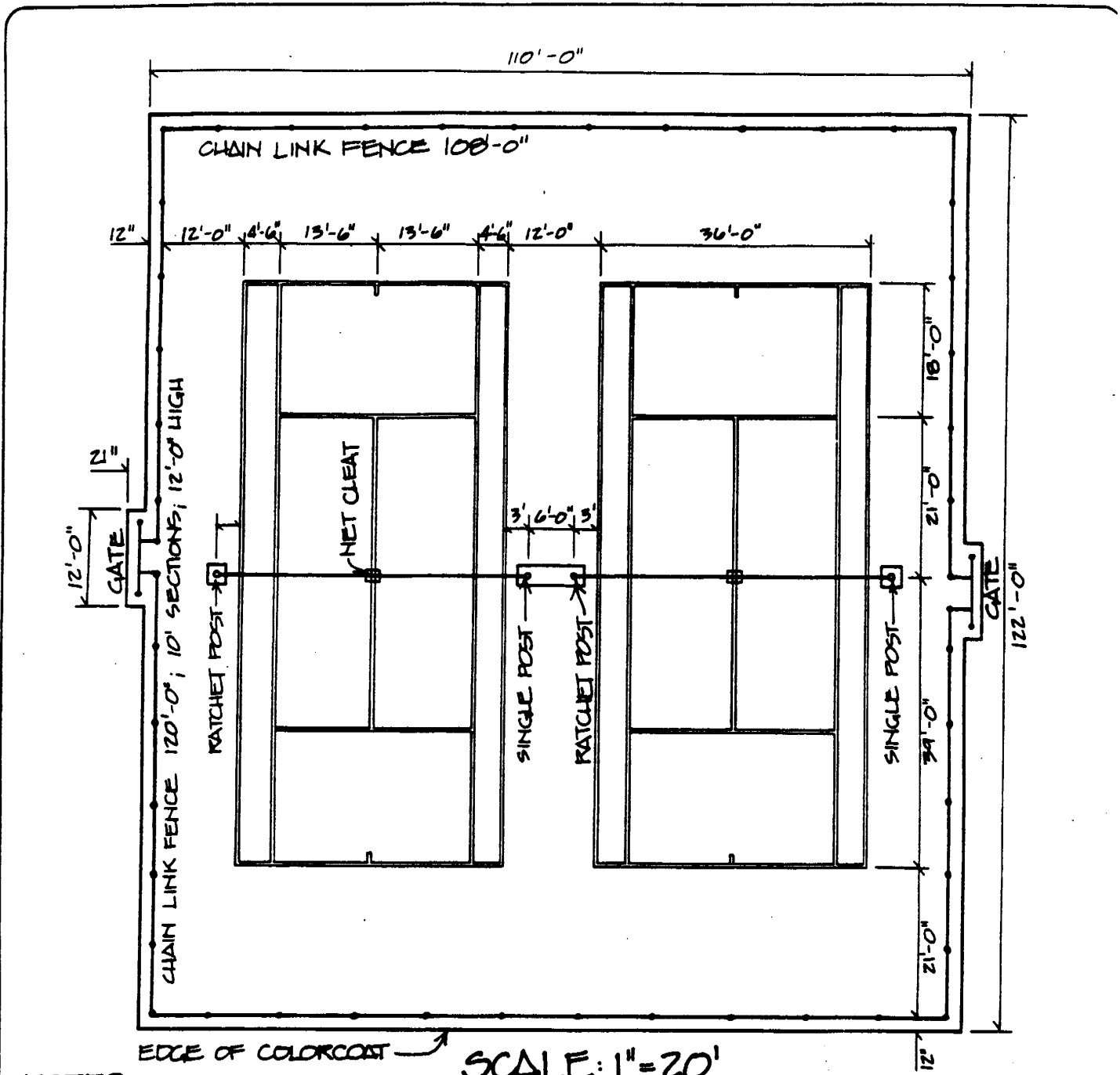

EDGE OF COLORCOAT

SCALE: 1" = 20'

NOTES:

1. SWINGING GATE OR SETBACK FENCE MAY BE USED FOR ENTRANCE. DETAIL #E4
2. GATES TO BE CENTER COURT.
3. ALL LINES TO BE WHITE 2" WIDE.
4. COLORCOAT MAY BE GREEN OR COMBINATION COLORS.
5. IF TOURNAMENT PLAY, USE CENTER CONDUIT ON NET LINE.

PLAN VIEW DOUBLE COURT

PARKS AND RECREATION FACILITIES
GUIDELINES © MARPC 1983

TENNIS

DEPARTMENT OF PARKS & RECREATION STANDARDS & SPECIFICATIONS, Prince George's County



Date Approved: 8/3/83

Paul E. Feller Md. P.L.A. #387

Drawn
MNM/CS

Date
7-83

Revised	Date

**DETAIL
E2**

Division of Planning, Design & Research

MARYLAND NATIONAL CAPITAL
PARK & PLANNING COMMISSION

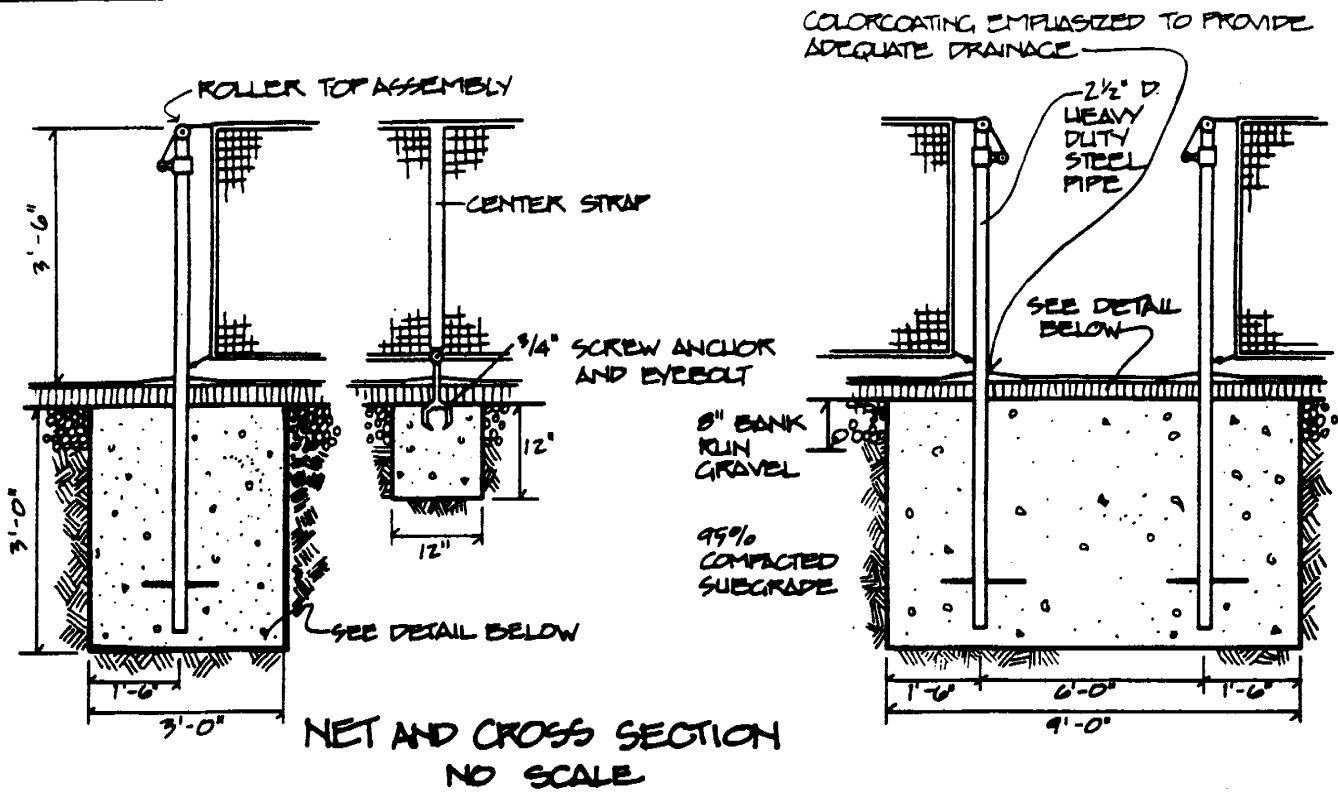

ENLARGED DETAIL FOR REMOVABLE NET POST
NO SCALE

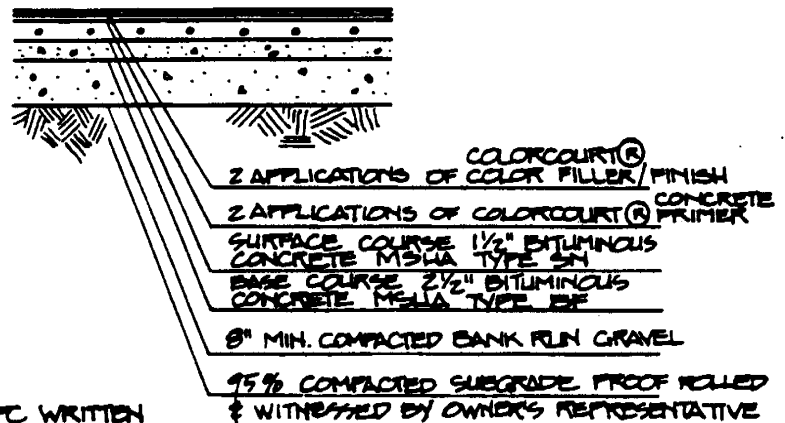
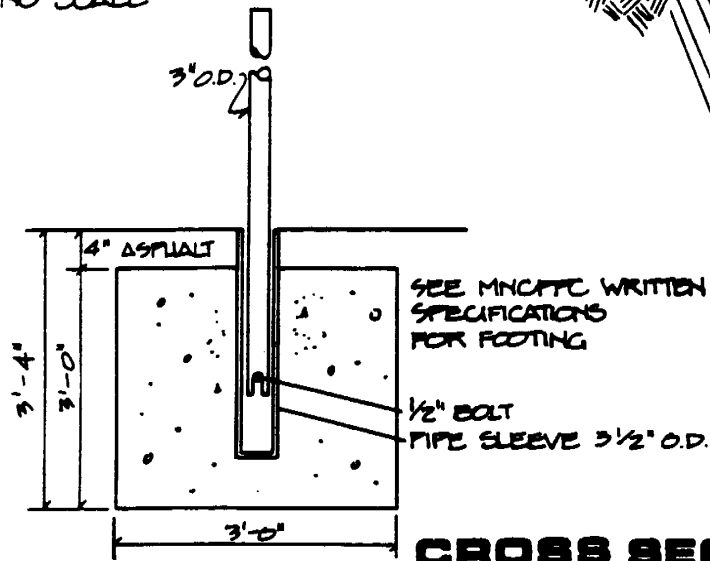

PAVING DETAIL
NO SCALE

CROSS SECTION, NET & PAVING

TENNIS

PARKS AND RECREATION FACILITIES
GUIDELINES © MNCPPC 1983

DEPARTMENT OF PARKS & RECREATION STANDARDS & SPECIFICATIONS, Prince George's County



Date Approved: 8/3/83
James E. Fuller Md. PIA #387

Drawn MNM
CS

Date 7-83

Revised	Date

**DETAIL
E3**

Division of Planning, Design & Research

MARYLAND NATIONAL CAPITAL
PARK & PLANNING COMMISSION

FENCE OPENING

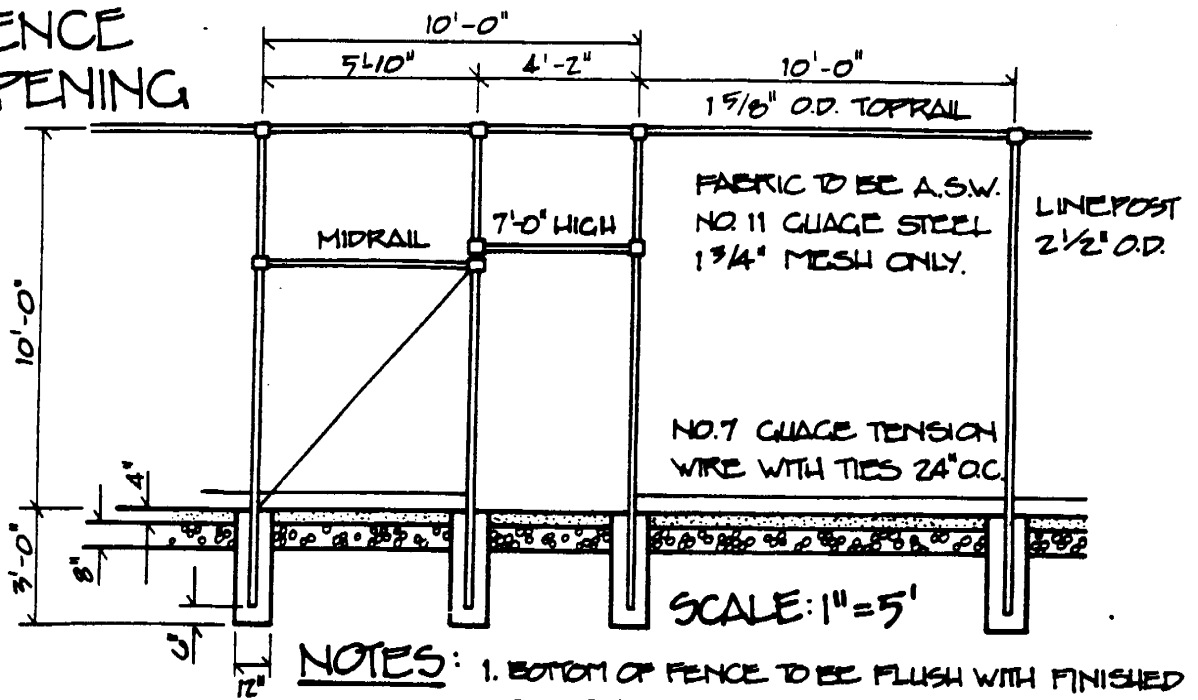

- NOTES:**
1. BOTTOM OF FENCE TO BE FLUSH WITH FINISHED COURT SURFACE.
 2. END POSTS 3" O.D.
 3. USE THREADED ELBOW OR WELD GATE CORNERS.
 4. FENCE ENTRANCE CAN BE MODIFIED FOR EITHER GATE OR FENCE.
 5. GATE SIZE DEPENDS ON LATCH AND LINGES.

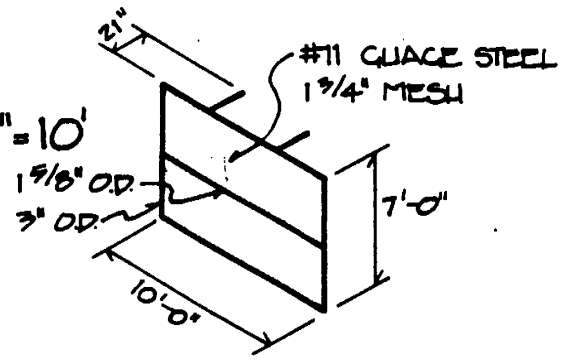
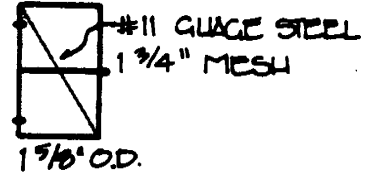
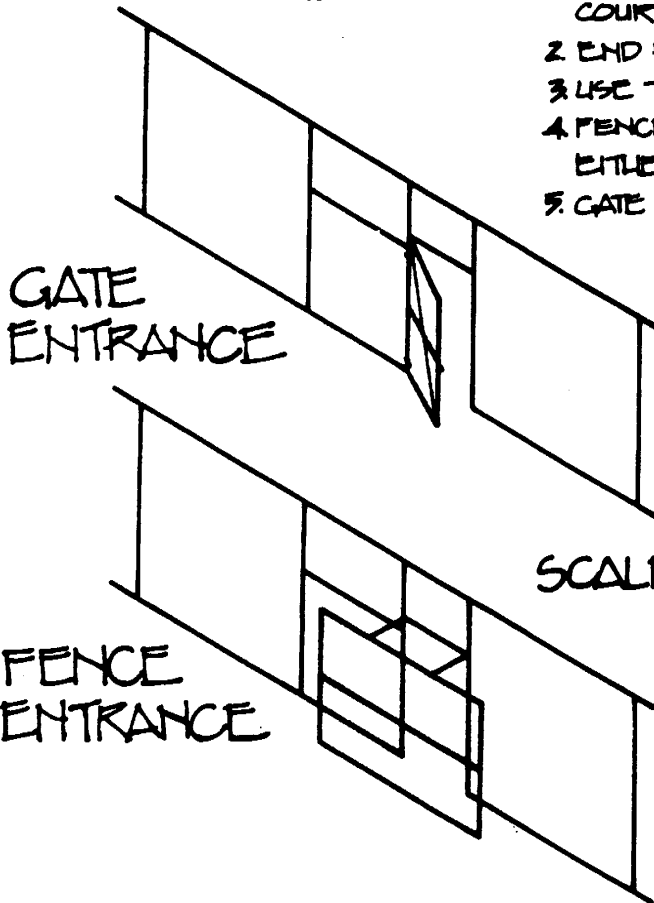

FENCE

TENNIS

PARCS AND RECREATION FACILITIES
GUIDELINES © MANDPPC 1983

DEPARTMENT OF PARKS & RECREATION STANDARDS & SPECIFICATIONS, Prince George's County



Date Approved: 8/3/85
James E. Felder Md. PIA # 387

Drawn <u>MNM/CS</u>	Date <u>7-83</u>	Revised	Date
------------------------	---------------------	---------	------

DETAIL
E4

Division of Planning, Design & Research

MARYLAND NATIONAL CAPITAL
PARK & PLANNING COMMISSION

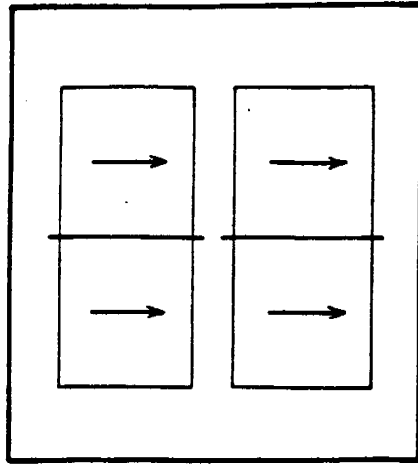

DOUBLE COURT

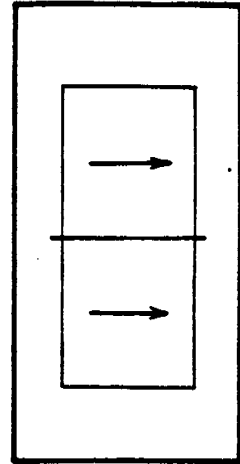

SINGLE COURT

FIRST PREFERENCE

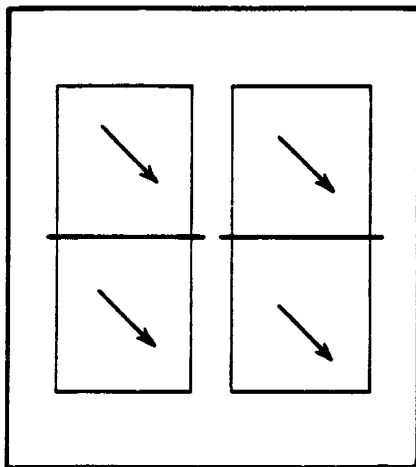

SECOND PREFERENCE

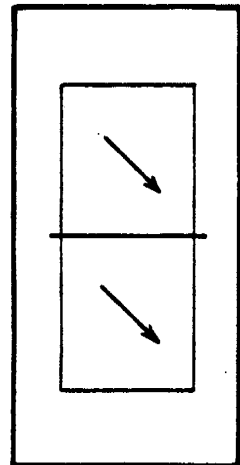

NOTES:

1. SLOPE ON COURTS 1%
2. COURTS MUST HAVE GOOD POSITIVE DRAINAGE AWAY FROM EDGES TO PREVENT EROSION.

SCALE: 1" = 50'

DRAINAGE

TENNIS

PARKS AND RECREATION FACILITIES
GUIDELINES © M-NOFPC 1983

DEPARTMENT OF PARKS & RECREATION STANDARDS & SPECIFICATIONS, Prince George's County



Date Approved: 8/3/83
Gene E. Jellen M.G. P.L.A. #387

Division of Planning, Design & Research

Drawn
MNM
CS

Date
7-83

Revised	Date

MARYLAND NATIONAL CAPITAL
PARK & PLANNING COMMISSION

DETAIL
E5

RECOMMENDED TENNIS COURT CONTRACTORS:

- A. Linear Contracting
9712 Dorval Avenue
Upper Marlboro, Maryland 20772
Phone: 868-8120
- B. Peak Incorporated
5010 Sunnyside Avenue
Beltsville, Maryland 20705
Phone: 441-8404
- C. Pickens & Sons, Inc.
6510 Haviland Mill Road
Clarksville, Maryland 21029
Phone: 854-2066
- D. Prince George's Contractors
P.O. Box 145
Clinton, Maryland 20735
Phone: 297-8760

SOFTBALL FIELD

Softball is a sport that is played by all age groups and both sexes, there are many active clubs that participate in leagues and tournaments. Rules and baselines and the distance to the pitching mound is modified to accommodate all leagues on the same 290' field. Use of the same field for all leagues will reduce the number of different size fields that have restrictions on play for certain leagues. Softball fields add a much needed open space to housing developments, a special 275' field has been designed for subdivisions.

A softball field is required at the rate of 1 per 3,000 persons in a proposed subdivision. The population of the subdivision is based on a per unit figure from the Planning Department, multiplied by the proposed number of dwelling units.

Unit type x persons/unit type=projected population.

A softball field may be sited singularly or in conjunction with other facilities in order to form a central recreation area.

The softball diamond is to be sited to have direct access from a path system. The backstop is to be located away from homes.

DESIGN REQUIREMENTS

1. Required

1 - 275' baseline softball field (homeowner's open space only) per 3,000 people.

1 - 290' baseline softball field (parkland) per 3,000 people.

2. Size

275' baseline for pick-up games and non-league play (Detail #F2)
290' baseline (110' skinned area) for league play can be utilized for boy's, girls, men's and women's leagues. (Detail #F1).

3. Orientation

The majority of softball in this area is played from early spring to mid-fall. During this time the sun is due west to 20° north of west. The most desirable orientation is to have the home plate to second base directly north/south with home plate facing north. See Detail # . If fields overlap, state on drawing which field has primary orientation.

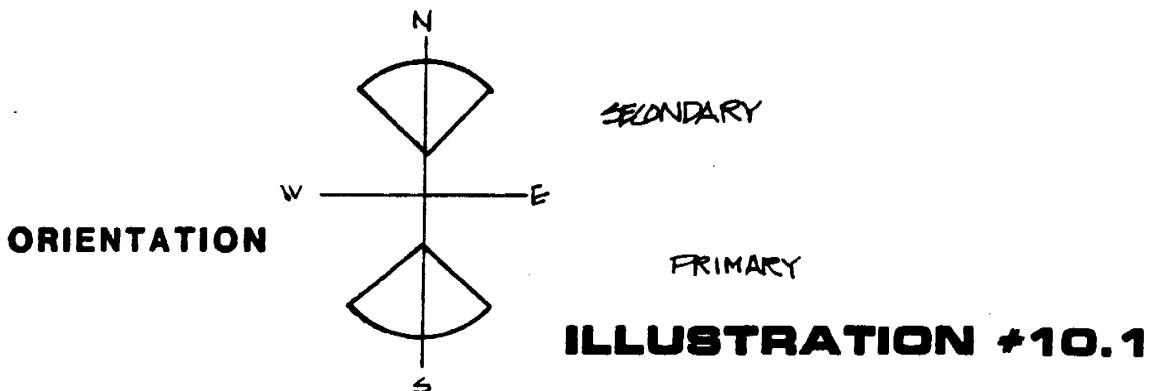

4. Overlapping

The softball field may be overlapped by soccer or football to accommodate more seasons of field use. When the fields are overlapped, the soccer or football field is to be free and clear of the skinned area on the softball field. The goal posts for football are to be outside the foul line play of the softball field. (Detail #F8)

5. Siting

Softball fields are not to be sited on, in, or under any of the following:

- a. 10 year flood plain for outfields only;
- b. Power lines;
- c. Man-holes;
- d. Skinned area and backstop are not to be sited on easements; or 100 year flood plain.
- e. Within 50 feet of parking lot, property lines, or roads.

6. Drainage (Detail #F7)

Occasionally it will be necessary to deviate from the preferred drainage patterns; if so, the following rules must be adhered to:

1. Skinned area is to be higher than all other areas of field.
2. Field should be symmetrically drained.

TYPICAL SOFTBALL FIELD SITING

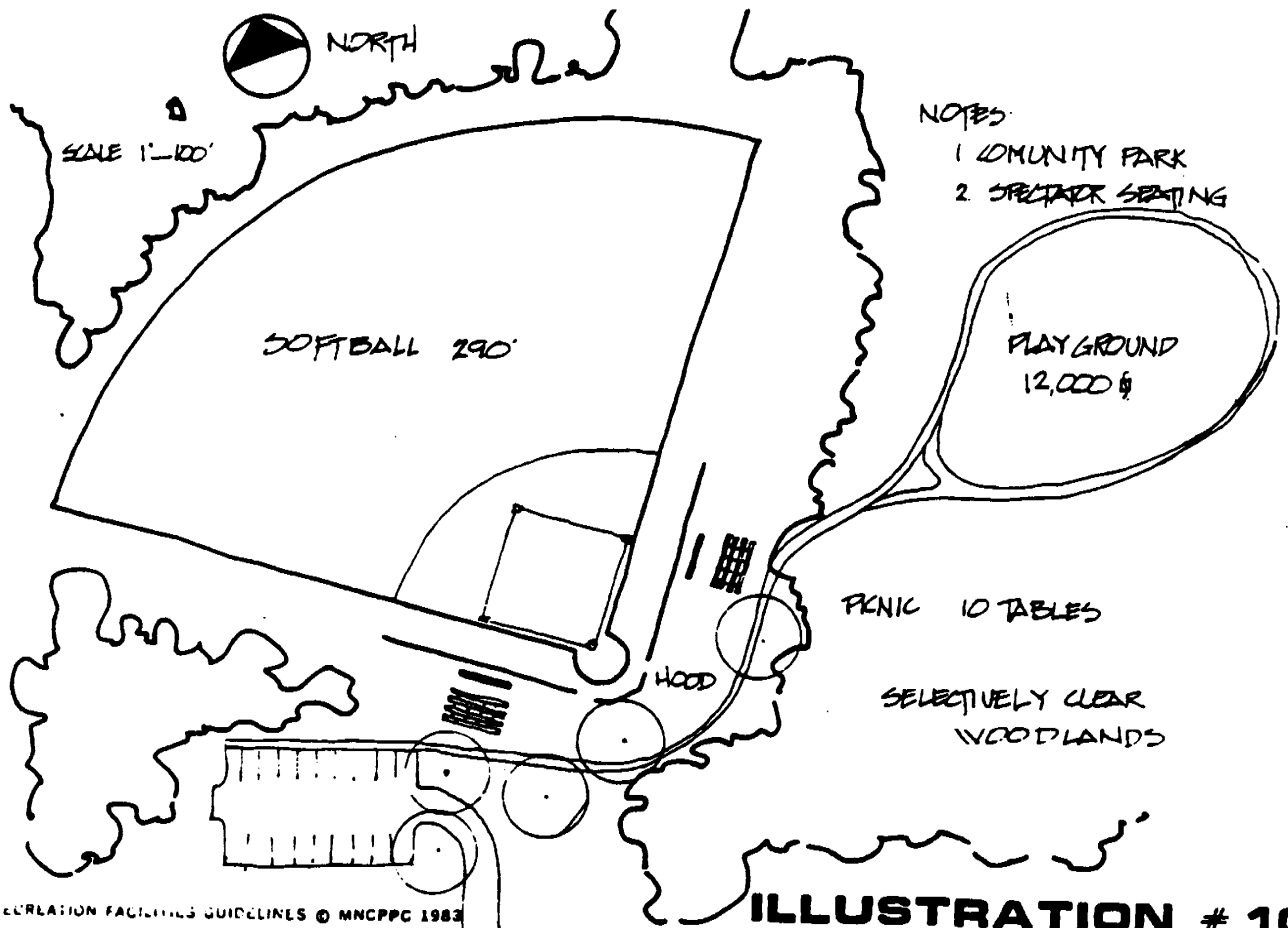

7. Pitcher Mounds - Not used in softball.

8. Hoods

Backstop without hood is required for all subdivision fields. (See Detail #F3)
Hooded backstops are to be used in areas where paths, roads, homes, or other fields are in proximity. (See Detail #F4)

9. Foul Line Fences

Foul line fences Detail #F1 are to be used when softball fields are not overlapping and are sited in community, neighborhood or regional parks.

10. Benches

Player benches (Detail #F1) are to be installed behind foul line fences for community, neighborhood, and regional parks. (It is anticipated that these will become programmed fields for league play).

11. Skinned Area

Special soil mix required 1/3 clay, 1/3 topsoil, 1/3 course sand to be placed in infield. See Design Specification.

CONSTRUCTION SPECIFICATIONS

Suggested Addition to Improve Facilities

Shading

If heavy use of fields is anticipated, an area for spectator seating that is shaded should be provided. This can be in several forms:

1. A landscaped grass hill
2. Bleacher with shade trees planted in proximity.
3. Architectural covering - awning, canopies, etc.

Trees sited near fields should have 3 guys per tree 120° apart. The first branch should be high enough to clear the top of the head of a person standing on the bleacher or a hill. Recommend 2-1/2 to 3" caliper minimum.

PLAN REQUIREMENTS

Written Specifications and Construction Details

Written specifications and details follow that are provided for the construction of softball fields. All fields are to be constructed in accordance with these specifications and details.

Preliminary Plat and Comprehensive Design Plan Requirements

The preliminary plat/comprehensive design plan is to indicate the location of the softball field(s) and its relationship to paths, property lines, parking and other recreational facilities.

Site Plan and Specific Design Plan Requirements

1. Site grading
2. Spot elevations
3. Landscaping
4. Paths
5. Buffers
6. Setback lines
7. Seating

Detail Sheet Requirements

1. Layout
2. Fencing
3. Entrances
4. Written Specifications
5. Cross sections
6. Plan view

CONSTRUCTION SPECIFICATIONS

1. SCOPE

The contract work to be performed under this section consists of all the required labor, material, equipment and services necessary to complete excavation and site work, as shown on drawings prepared by the applicant. It includes excavating, pumping, backfilling, and rough grading to elevations as shown for completion of work, as specified.

2. CLEARING SITE

The site development plan shows areas to be cleared.

(a) Clearing:

(1) Limits of clearing shall be confined to those areas as shown on the plans, or as required by the typical grading and paving sections. The clearing line is to be marked in the field by the Contractor. Activity by the Contractor beyond these limits shall be at the authorization of the Engineer and/or Landscape Architect. At several locations, the grading may have to vary slightly to avoid destruction of specimen trees.

(2) Clearing shall include demolition and removal of all trees, saplings, brush, downed timber, shrubs, rotten wood, rubbish, vines, undergrowth, and any other vegetation from the area of game courts, walkways, and facilities. Clearing shall also include other trees as shown on the plans and so designated for removal. Demolition shall include root system of trees, as well as the removal of fences and incidental structures.

(b) Grubbing:

(1) Limits of grubbing shall coincide with limits of clearing, unless otherwise specified.

(2) Grubbing shall include removing from the ground all stumps, roots and stubs, brush, organic materials, and debris within the limits of grubbing.

(c) Disposal:

(1) Burning of materials on site shall not be permitted.

(2) Where chips are to be utilized on a site the trees may be chipped.

The following generally pertains to parkland development:

(3) All trees shall be thoroughly chipped and used as mulch on site. Chipped material shall be stockpiled on site, as shown on the plans.

(4) Maximum size chipped particles shall be three (3) inches in any dimension.

(d) General:

(1) The Contractor shall visit the site to determine the existing conditions and shall be held responsible for all demolition covered under these specifications.

(2) The Contractor's attention is specifically directed to the Maryland State Highway Administration Specifications, Section 31.01-12, Subparagraphs 1 and 7, referring to tree trimming and scar repairs.

(e) Field Quality Control:

(1) The Engineer and/or Landscape Architect shall approve the clearing line prior to any clearing.

(2) After clearing and grubbing has been completed, the Engineer will inspect damage to remaining trees and shall direct the contractor to repair damage. Repairs shall be done by a professional tree surgery firm at no expense to the Owner.

(f) Demolition on Site:

(1) Protection to Persons and Property: All work shall be scheduled and executed in a careful manner with due consideration for workmen and the public, and to prevent injury to any persons or property.

(2) Use of Explosives: Do not do any blasting on the project site without written permission of the Engineer and unless it is done in accordance with applicable laws and regulations.

(g) Clean-Up:

(1) Remove from the site any stumps, dead trees, broken and loose branches, rubbish, and debris resulting from demolition, unless otherwise specified.

(2) Leave the site in a safe, clean condition.

(3) After demolition and removal work is completed, do not store on site any materials resulting from demolition or any tools and equipment used for work.

SCALE: 1" = 30'

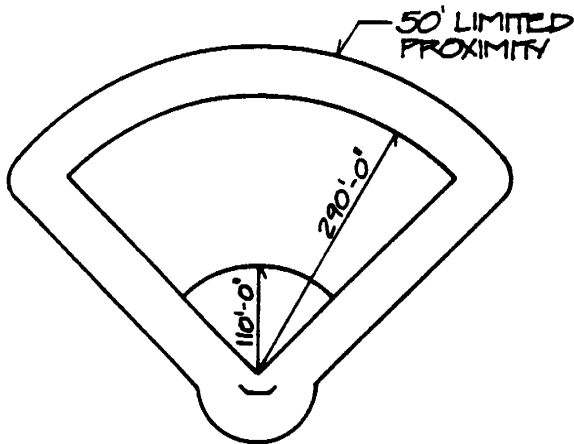
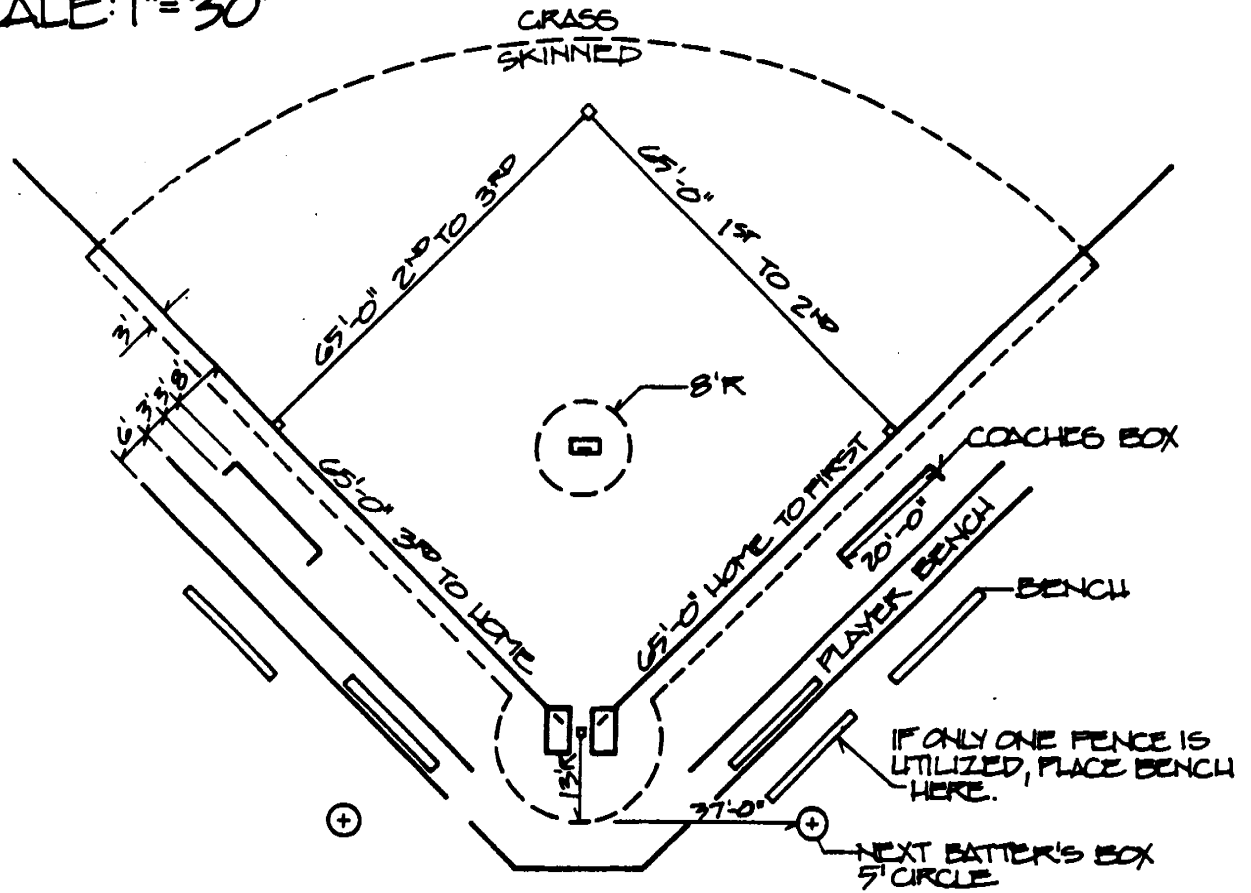

SCALE: 1" = 200'

NOTES:

1. REGIONAL PARKS USE PERMANENT HOLLYWOOD BASES.
2. COMMUNITY-NEIGHBORHOOD SET: HOME AND PITCHERS.
3. BACKSTOP MINIMUM 20' FROM HOME PLATE, MAXIMUM 60'.
4. FOR BACKSTOP SEE DETAILS # F-3 AND F-4.
5. FOR BASE LAYOUT SEE DETAIL # F-6.

290' SOFTBALL FIELD LAYOUT

SOFTBALL

PARKS AND RECREATION FACILITIES
GUIDELINES © M-NCPPC 1983

DEPARTMENT OF PARKS & RECREATION STANDARDS & SPECIFICATIONS, Prince George's County



Date Approved: 8/3/83
Grace E. Follen M.A. RA# 387

Drawn
MNY
CS

Date
7/83

Revised

Date

DETAIL
F1

Division of Planning, Design & Research

MARYLAND NATIONAL CAPITAL
PARK & PLANNING COMMISSION

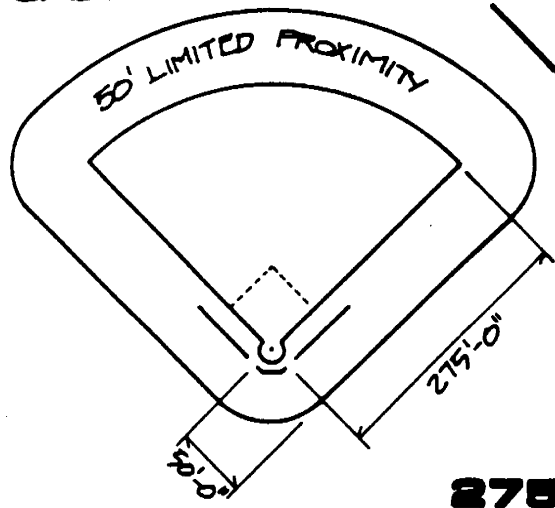
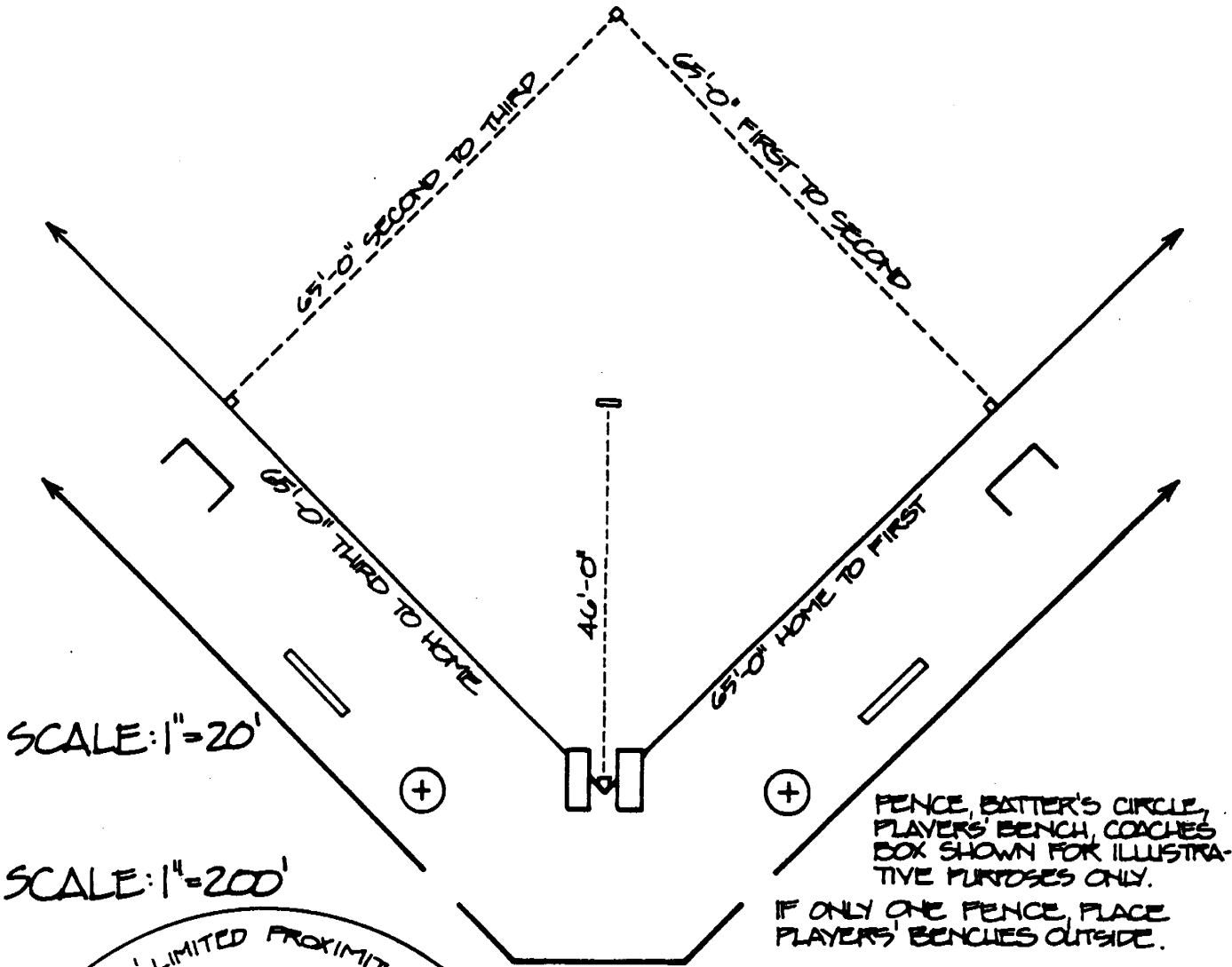

- NOTES:**
1. NO SKINNED AREA FOR SUBDIVISION.
 2. PROVIDE BACKSTOP (NO HOOD) WITH MOW STRIP.
 3. SET PINS FOR:
HOME PLATE, PITCHER'S PLATE, BASES
 4. FLAG PINS FOR FINAL INSPECTION.

275' SOFTBALL FIELD LAYOUT

SOFTBALL <small>PARKS AND RECREATION FACILITIES GUIDELINES © M-REPPC 1983</small> <small>DEPARTMENT OF PARKS & RECREATION STANDARDS & SPECIFICATIONS, Prince George's County</small>						
	Date Approved: <u>8/3/83</u>	Drawn <u>MINM</u>	Date <u>7/83</u>	Revised	Date	DETAIL F2
	<u>Grace E. Fuller MA RLA#387</u>	<u>CS</u>				
<small>Division of Planning, Design & Research</small>			<small>MARYLAND NATIONAL CAPITAL PARK & PLANNING COMMISSION</small>			

NOTES:

USE NONHOODED BACKSTOP FOR

- A. SUBDIVISION FIELDS
- B. IN PARKS WHERE THEY BACK TO UNDEVELOPED WOODLANDS

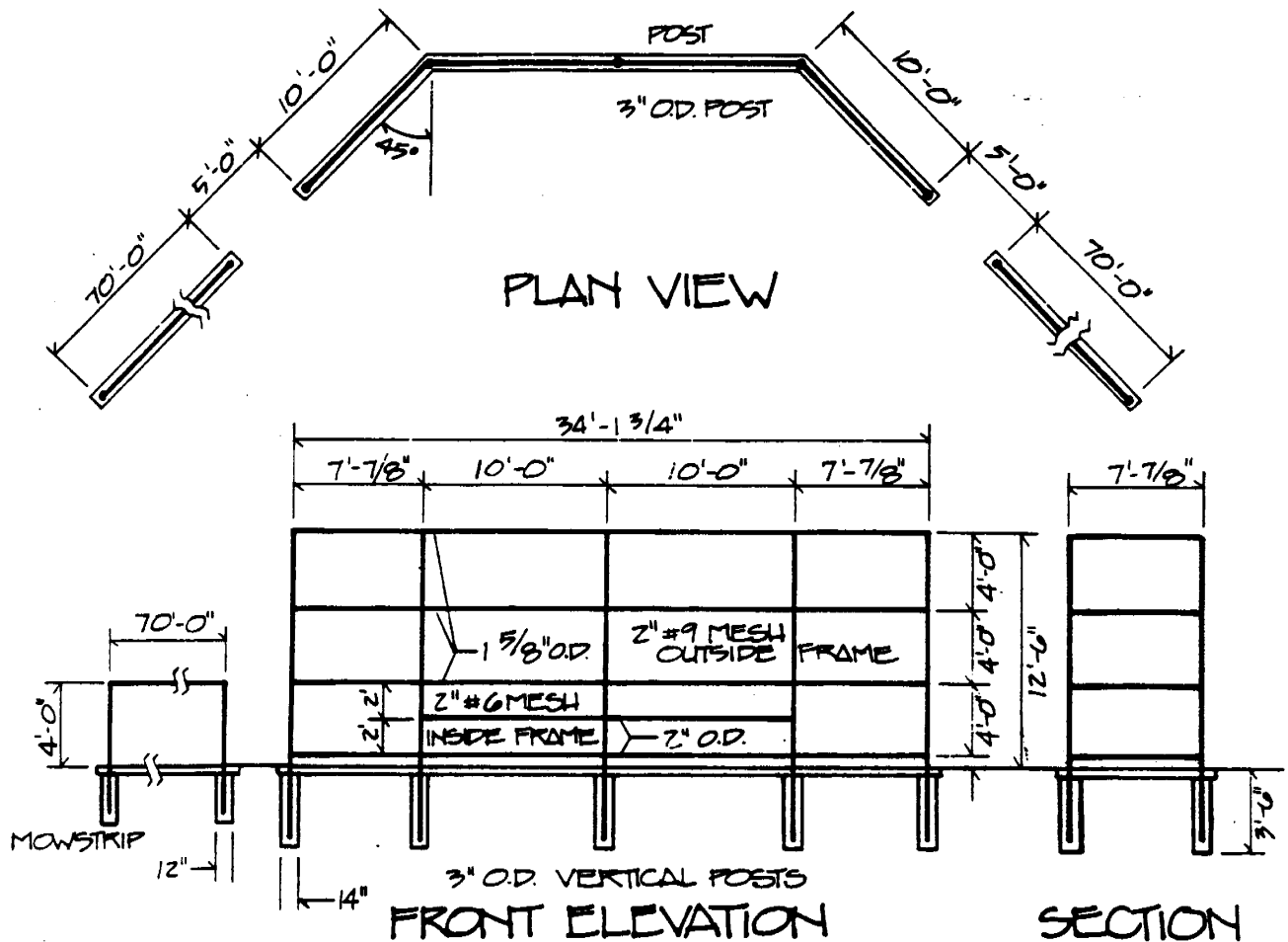

SCALE: 1" = 10'

NONHOODED BACKSTOP

SOFTBALL

PARKS AND RECREATION FACILITIES
GUIDELINES MNCPPC 1983

DEPARTMENT OF PARKS & RECREATION STANDARDS & SPECIFICATIONS, Prince George's County



Date Approved: 8/3/83
Greg E. Felder Md. RLA #387

Division of Planning, Design & Research

Drawn
MNM
CS

Date
7/83

Revised	Date

MARYLAND NATIONAL CAPITAL
PARK & PLANNING COMMISSION

DETAIL
F3

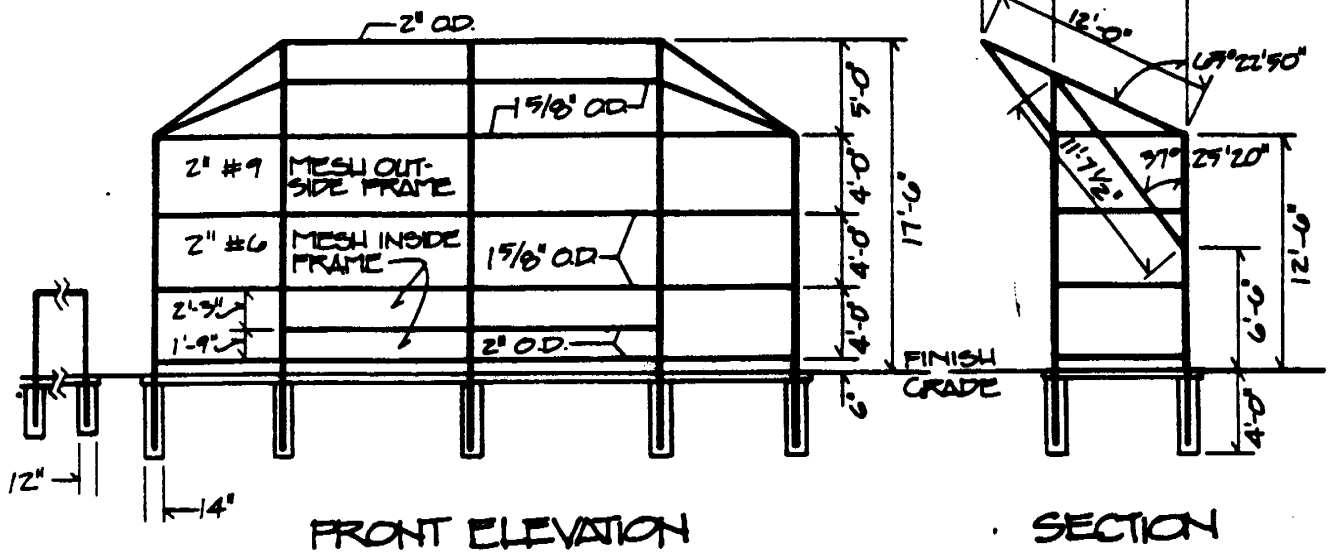
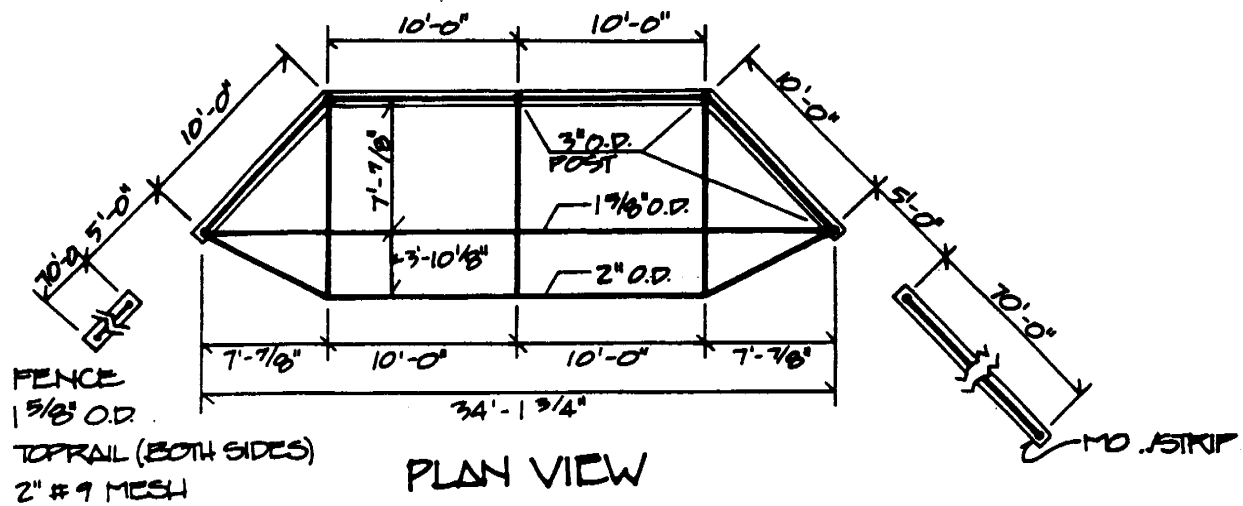

SCALE: 1" = 10'

HOODED BACKSTOP

SOFTBALL

PARIS AND RECREATION FACILITIES
GUIDELINES © MNCPPC 1983

DEPARTMENT OF PARKS & RECREATION STANDARDS & SPECIFICATIONS, Prince George's County



Date Approved: 8/3/83
Ann E. Fuller Md. B.L.A. # 387

Drawn MNM/CS

Date 7/83

Revised	Date

DETAIL F4

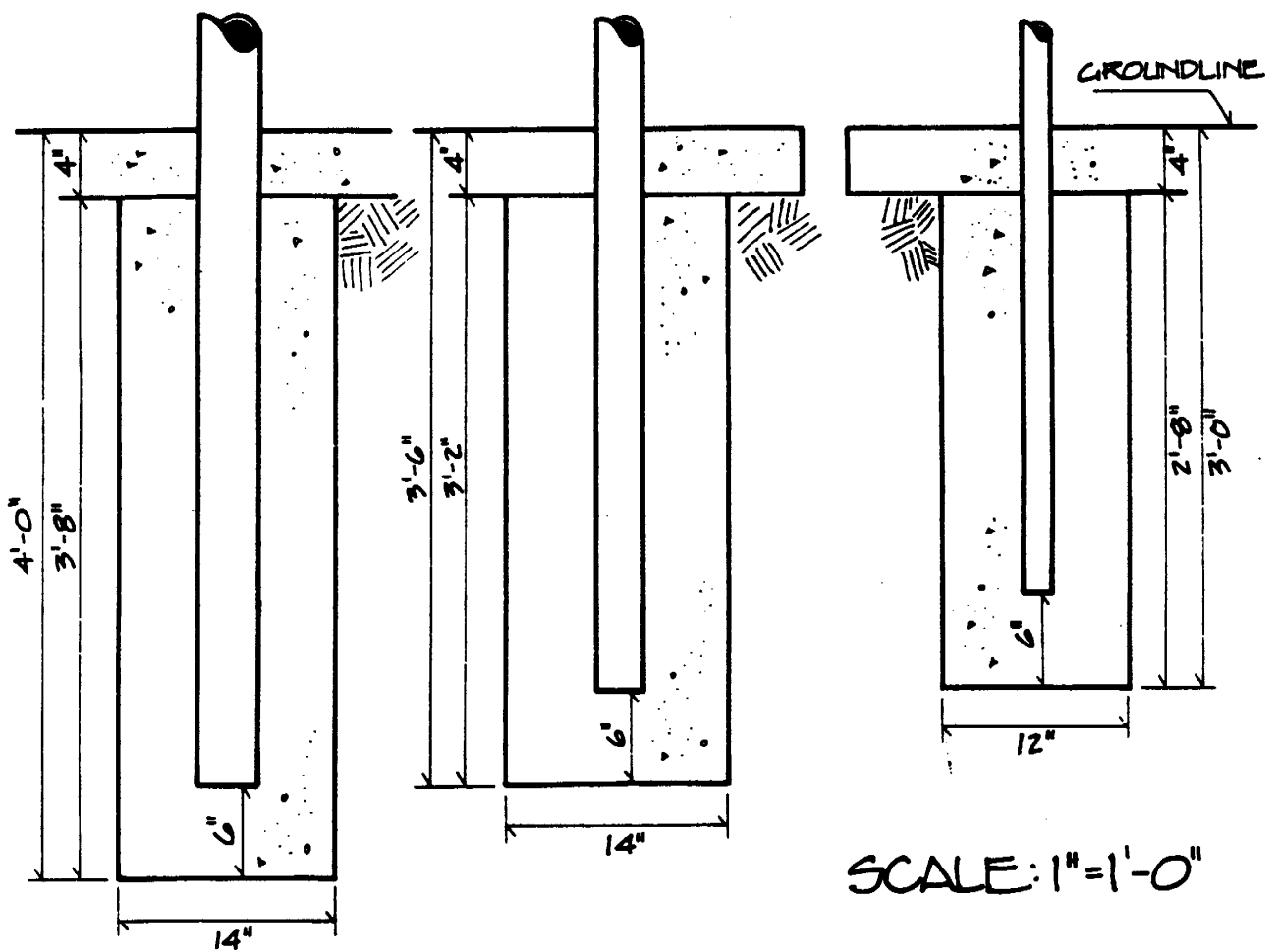
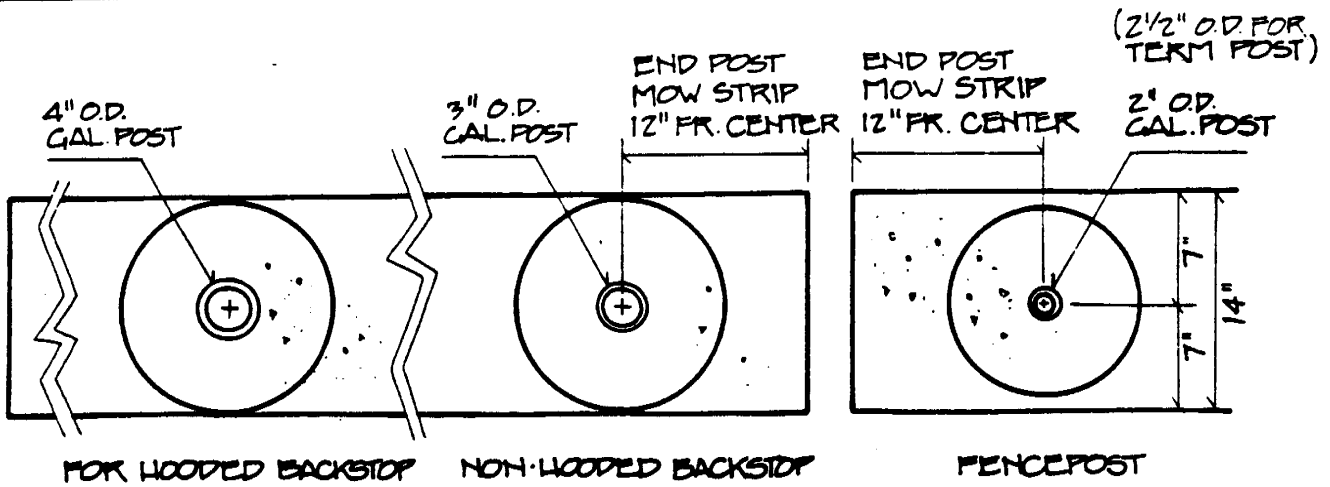

BACKSTOP AND FENCE POST FOOTINGS

SOFTBALL

PARKS AND RECREATION FACILITIES
GUIDELINES - M NEPPC 1983

DEPARTMENT OF PARKS & RECREATION STANDARDS & SPECIFICATIONS, Prince George's County



Date Approved: 8/3/85
James E. Fuller Md. RLA # 387

Division of Planning, Design & Research

Drawn
MM/CS

Date
7-83

Revised

Date

MARYLAND NATIONAL CAPITAL
PARK & PLANNING COMMISSION

DETAIL
F5

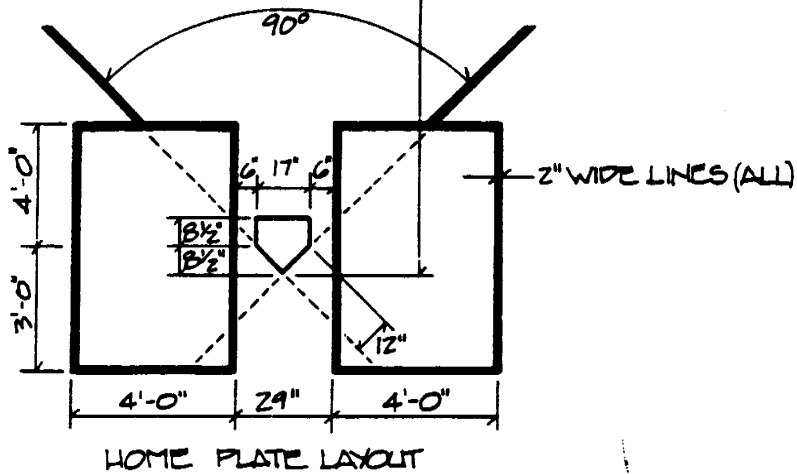
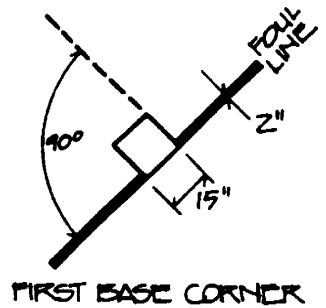
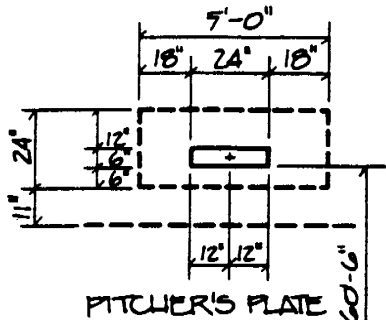
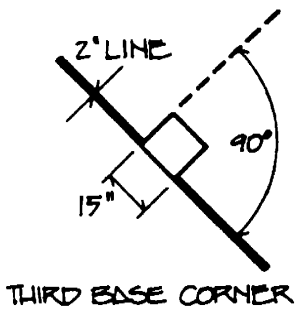
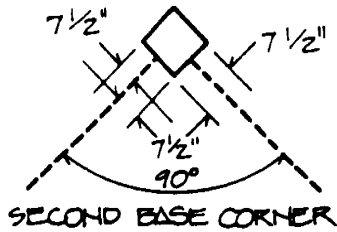

NOTES:

1. REGIONAL PARKS USE 65' BASE
PERMANENT HOLLYWOOD BASES - SLEEVES TO 60'-75'
2. COMMUNITY USE MOVABLE BASES 60'-75'
HOMEPLATE PERMANENT, PITCHING RUBBER 46'
3. 110' SKINNED AREA REGIONAL AND COMMUNITY.

NO SCALE

BASE LAYOUTS

PARKS AND RECREATION FACILITIES
GUIDELINES MNCPPC 1983

SOFTBALL

DEPARTMENT OF PARKS & RECREATION STANDARDS & SPECIFICATIONS, Prince George's County



Date Approved: 8/5/83

Francis E. Fisher MD RLA # 587

Division of Planning, Design & Research

Drawn
MNM
CS

Date
7/83

Revised

Date

MARYLAND NATIONAL CAPITAL
PARK & PLANNING COMMISSION

DETAIL
F6

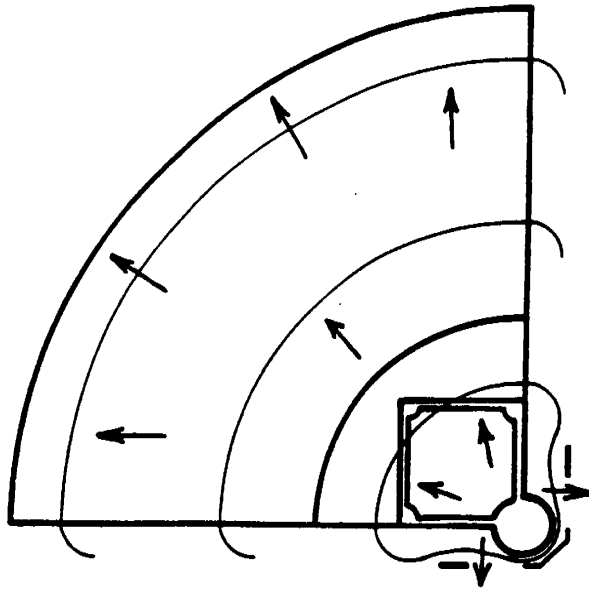

FIRST PREFERENCE

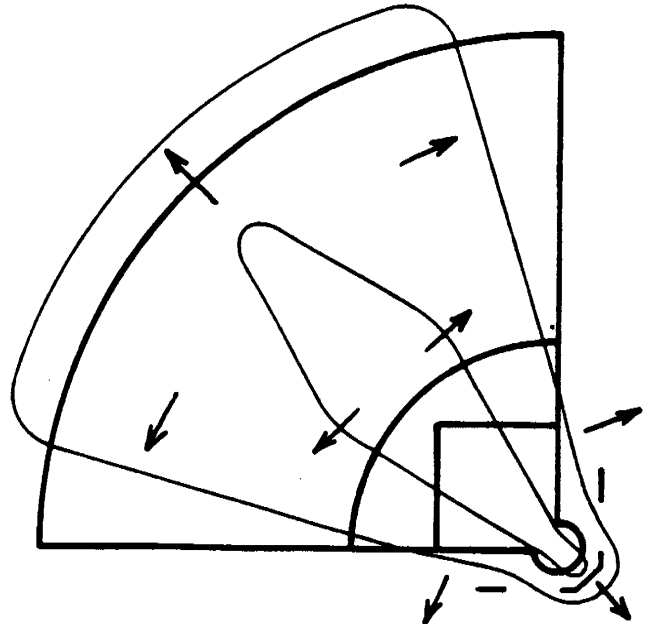

SECOND PREFERENCE

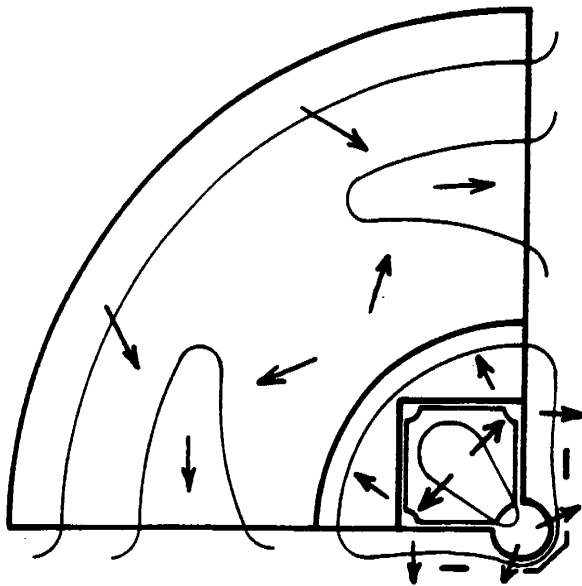

THIRD PREFERENCE

2% SLOPE

SCALE: 1"=100'

DRAINAGE

SOFTBALL

PARKS AND RECREATION FACILITIES
GUIDELINES © M-RCPPC 1983

DEPARTMENT OF PARKS & RECREATION STANDARDS & SPECIFICATIONS, Prince George's County



Date Approved: 8/5/83

James E. Feltner Md. P.L.A. #387

Division of Planning, Design & Research

Drawn
MNM
CS

Date
7/83

Revised	Date

**DETAIL
F7**

MARYLAND NATIONAL CAPITAL
PARK & PLANNING COMMISSION

NOTES:

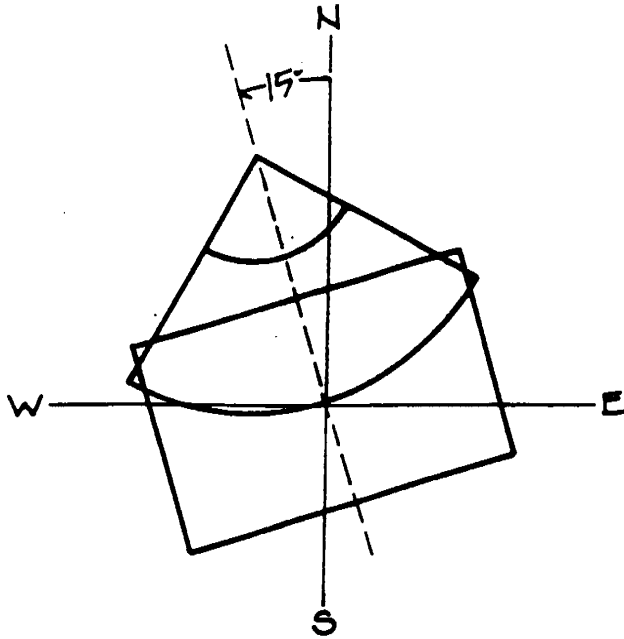

1. GOAL POSTS MUST BE REMOVED AT END OF SEASON.
2. ORIENT SOFTBALL 15° N.W.
3. SITE FOOTBALL/SOCCER BEYOND 110' SKINNED AREA.
4. NO OUTFIELD OR FOUL LINE FENCING IS TO BE USED ON SOFTBALL AREA

☐ INDICATES FIELD WITH PREFERENTIAL ORIENTATION.

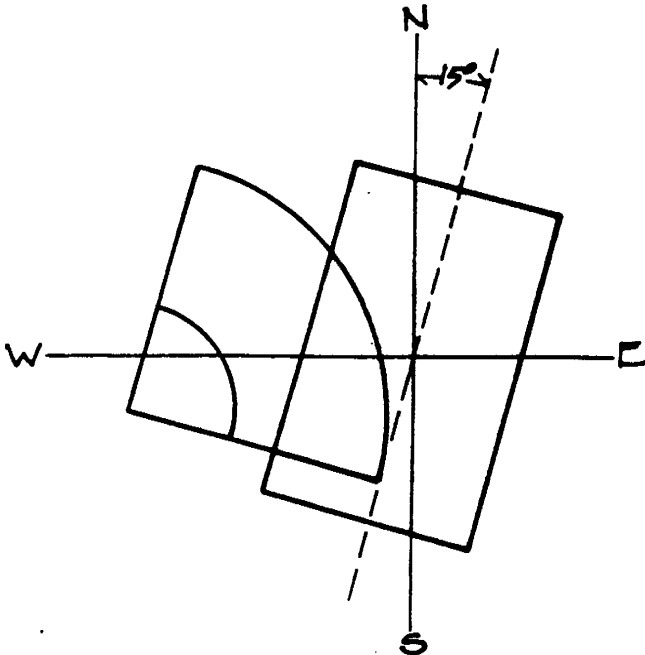

NOTES:

1. GOALPOSTS MAY BE LEFT THROUGHOUT THE YEAR.
2. ORIENT FOOTBALL/SOCCER 15° N.E.
3. SITE FOOTBALL/SOCCER BEYOND 110' SKINNED AREA.
4. NO OUTFIELD OR FOUL LINE FENCING ON SOFTBALL AREA.

SCALE: 1" = 200' COMBINATION FIELD OVERLAYS

SOFTBALL

PARKS AND RECREATION FACILITIES
GUIDELINES © M-ADPPC 1983

DEPARTMENT OF PARKS & RECREATION STANDARDS & SPECIFICATIONS, Prince George's County



Date Approved: 8/3/03

Gregory J. Fidler Md. RLA #387

Division of Planning, Design & Research

Drawn
MNM
CS

Date
7/03

Revised

Date

DETAIL
F8

MARYLAND NATIONAL CAPITAL
PARK & PLANNING COMMISSION

3. GRADING

The grading plan shows the extent of areas to be graded. All grades shall be in accordance with plans.

- (a) Soil Tests: Soil tests have not been made to determine the characteristics of the soil and the level of the water table, except as shown on the plans.
- (b) Subsurface Conditions: The Contractor is to examine information shown on the plans, and is to examine the site, making such tests as deemed necessary to determine the conditions and nature of the soil.
- (c) Bench Marks and Monuments: Carefully maintain all benchmarks, monuments, and other reference points. If disturbed or destroyed, replace as directed.
- (d) Finished Grades: Refer to the required grade elevations indicated. If finished grades shown by spot elevations conflict with those shown by contours, spot elevations shall be used. Unless indicated, the project site area shall be given uniform slopes between points for which finished grades are shown, or between such points and existing established grade, except vertical curves or roundings shall be provided at abrupt changes in slope. Do all grading required to bring the entire project area to finished grades.
- (e) Debris: Remove from the site all debris and excavated material not suitable, or not needed for fill.

4. SITE DRAINAGE

1. GENERAL

See Site Development Plan.

2. SCOPE

The contract work to be performed under this section consists of all the required labor, material, equipment, and services necessary to complete site drainage, as shown on the drawings.

5. TOPSOIL, SEEDING AND SOD

(2) Scope:

- (1) Sodding and seeding are to be as included in the contract.
- (2) The contract work to be performed under this section consists of all the required labor, material, equipment, and services necessary to install topsoil, as shown on the drawings or as specified herein.
- (3) The smallest practical area of land is to be exposed at any one time during development.

- (4) Make provisions to effectively accommodate the increased runoff caused by changed soil and surface conditions during development.
- (5) Natural vegetation must be retained and protected.
- (6) The permanent final vegetation and structures must be installed as soon as practical in the development of this site.

(b) Topsoil:

- (1) Stripped topsoil is to be reasonably free of woody plants, stones over one inch (1) in size, construction debris, excavated material, deleterious matter.
- (2) Topsoil is to be approved by the Engineer and/or Landscape Architect before installation, and is to consist of a sandy loam containing 2 to 2.5 organic matter free of debris, rock, and gravel.
- (3) Furnish and spread four inches (4") of topsoil over disturbed areas.
- (4) Spread evenly to true contours and hand rake to an even, smooth surface ready for seeding.
- (5) Regrade and fill low spots after shrinkage.
- (6) Existing topsoil, if acceptable, may be used as far as it will go. New topsoil is to be brought in, as necessary to build up required grading. Any tests required to determine the quality of the topsoil, both existing and new, will be made where, and as directed by, the Engineer and/or Landscape Architect, at no expense to the Owner.

(c) Seeding:

- (1) Grass seed shall be Maryland State Certified and mixed in the following percentages by weight:

<u>SEED</u>	<u>PERCENT OF MIX</u>	<u>PERCENT GERMINATION</u>	<u>PERCENT PURITY</u>	<u>PERCENT WEED SEED CONTENT</u>
Kentucky Bluegrass	50	75	85	.40
K-31 Tall Fescue	90	85	98	.50

(2) Seeding Operation

Seed shall be sown at the rate of 6-8 lbs./1,000 square feet or 250 lbs./acre.

The seed shall be spread by mechanical spreaders at the rate previously specified. Seeding shall be done in two directions, the second being perpendicular to the first, using one-half of the amount of seed in each direction. The seed shall be in firm contact with the seed bed and raked into the top one-fourth inch (1/4") of topsoil. The contractor shall have the option of rolling the seed into the topsoil, rather than raking. If the Contractor elects to roll, the roller shall weigh no more than 150 pounds.

- b. Fertilizer shall be a commercial chemical fertilizer, 50% of the nitrogen of which is derived from natural organic sources of ureaform. The fertilizer shall contain the following percentages by weight:

20% of nitrogen
20% phosphoric acid
10% potash

Fertilizer shall be applied at the rate of 220 pounds per acre to the areas to be seeded and sodded.

- (3) Ground Limestone shall conform to MSHA, Article 20.05, Section 20.05-3.

- (4) In no event shall more than forty-eight (48) hours elapse between the cutting and planting of the sod.

- (5) Water shall be clean and potable, suitable for drinking.

- (6) Straw Mulch shall consist of thoroughly threshed wheat, rye, or oat straw.

- (7) Binder Terra Tac AR or approved equal.

- (d) Sod:

Sod shall be cultivated bluegrass fescue mixture grown in an established turf nursery for at least two (2) years before lifting. Sod shall be free of insects, grubs, and apparent disease, and shall show proof of a current Nursery Inspection Certificate.

(1) Sod shall have been mowed prior to stripping and shall have been maintained for a minimum of three (3) months at or near the height of final clipping at the nursery. Maximum height: two and one-half inches (2-1/2").

(2) Sod shall be machine stripped at a uniform soil thickness of approximately one inch (1"), plus-or-minus one-quarter inch (1/4"). Though thinner cuts tend to accelerate knitting and are, therefore, preferred, the minimum acceptable soil thickness shall be three-quarter inch (3/4"). Measurement for thickness shall include the growth and thatch.

(3) Individual pieces of sod shall be cut to the supplier's standard width and length. (Maximum allowable deviation from standard width and length is five (5) percent.) There shall be no broken pads, torn or uneven ends.

(4) In no event shall more than forty-eight (48) hours elapse between the cutting and planting of the sod.

(5) Before placing sod upon any surface, all shaping and dressing of such surfaces shall have been completed to grades on plan. The completed areas to be sodded shall present a smooth, uniform, well tilled surface, and any raking required to accomplish this shall be done immediately prior to the placing of the sod.

(6) Sodding shall be performed during the proper season for such work. No frozen sod shall be used, and no sod shall be placed upon frozen soil.

(7) Maintenance - Sod shall be kept moist until it has become established, and its continued growth assured, or until accepted.

(8) Slopes - On slopes two-to-one (2:1) and steeper, sod shall be laid with the long edges parallel to the contour starting at the bottom of the slope. Succession strips shall be neatly matched, and all joints staggered or broken. When placing sod in drainage ditches, the length of the strip shall be laid parallel to the direction of the flow of the water.

(9) Each strip or section of sod placed on slopes two-to-one (2:1) and steeper, and surface drainage V-shaped or flat bottom ditches or gutters, shall be staked securely with at least two (2) stakes spaced not more than two feet (2') apart with the flat side against the slope. Stakes may be wood wedges and shall be 1/2" x 1" x 12" to 1/2" x 1" x 15" driven flush with the top of the sod.

(10) Guarantee - Sodded areas which do not show a prompt catch shall be resodded at no expense to the Owner.

(6) MULCHING

The mulch shall be applied over the seeded areas in an approved manner. The rate of application shall average 115 pounds per 1,000 square feet with a minimum of 90 pounds and a maximum of 140 pounds per 1,000 square feet so as to provide a loose depth of not less than one and one-half inches (1-1/2") nor more than three inches (3").

Uniform distribution and depth of mulch must be obtained. After the mulch is in place, all mulched surfaces shall be sprayed with asphalt binder material so that the surface has a uniform appearance. The binder shall be applied to the mulch at the rate of eight (8) gallons per 1,000 square feet. A spray nozzle of approved design shall be used. The nozzle shall be operated at a distance of not less than four feet (4') from the surface of the mulch. A pump or air compressor of adequate capacity shall be used to insure uniform distribution of the bituminous material.

(7) TIME OF SEEDING AND SODDING

March 1 to May 1 and August 1 to October 31, inclusive.

(8) SKINNED AREA (Arrangements may be made with DPR to complete the skinned area after finished grade is established).

Skinned area is to be covered with a soil mix of 1/3 coarse sand, 1/3 topsoil and 1/3 clay that is well mixed, free and clear of all mud seed, debris, branch or root matter, rock and stone.

Soil mix to be placed on field in "turtle back" with high point at pitcher's mound that is 6 to 8" higher than finished grades, feathering to 1" on the outer edges of the infield. Placement is to be followed by hand raking.

(9) MAINTENANCE

The Contractor shall maintain all seeded and sodded areas for a period of not less than 45 days nor more than 60 days. Maintenance shall consist of watering, weeding, mowing, repairing of all erosion and settlement, and re-seeding or resodding of lawn areas, as necessary, to establish a weed-free, dense, closely knit turf of the grasses specified.

At the time of the first mowing, mower blades shall be set between two and two and one-half inches (2'-2-1/2"). All newly seeded and sodded areas shall receive at least three (3) mowings before acceptance of lawns. Remove all grass clippings during or immediately after mowing.

Maintenance shall also include any temporary protection fences, barriers, and signs, as well as all other work incidental to proper maintenance.

BASEBALL FIELD

Baseball is a sport played predominately by leagues, and therefore it should be placed in an area with adequate parking, and spectator benches.

A baseball field is required at the rate of 1 per 6,000 persons in a proposed subdivision. The population of the subdivision is based on a per unit figure from the Planning Department multiplied by the proposed number of dwelling units.

Unit type x persons/unit type=projected population.

A baseball field may be sited singularly or in conjunction with other facilities in order to form a central recreation area. It is more practical to site a baseball field with other major facilities.

The baseball diamond is to be sited to have direct access from a path system and parking.

DESIGN REQUIREMENTS

1. Required

1 - 310' foul line baseball field per 6,000 persons.

2. Size

310' foul line radius and 350' centerline radius (Detail #G1)

3. Orientation

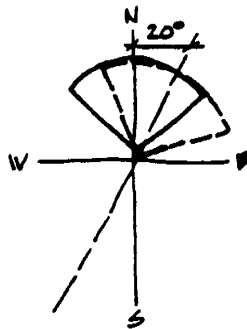

ORIENTATION

ILLUSTRATION # 11.1

The majority of baseball in this area is played from early spring to mid-fall. During this time, the sun is due west to 20° north of west. The most desirable orientation is to have the home plate to second base directly facing north. The field may be rotated 20° to the east.

4. Overlapping

Not permitted for baseball field.

5. Siting

Baseball fields are not to be sited on, in, or under any of the following:

- a. 100-year flood plain
- b. Power lines.
- c. Man-holes.
- d. Within 50 feet of parking lot, property line, lot lines, roads.
- e. Skinned area and backstop are not to be sited on easements or in the 100 year flood plain.

6. Drainage (Detail #G5)

Do not deviate from preferred drainage patterns.

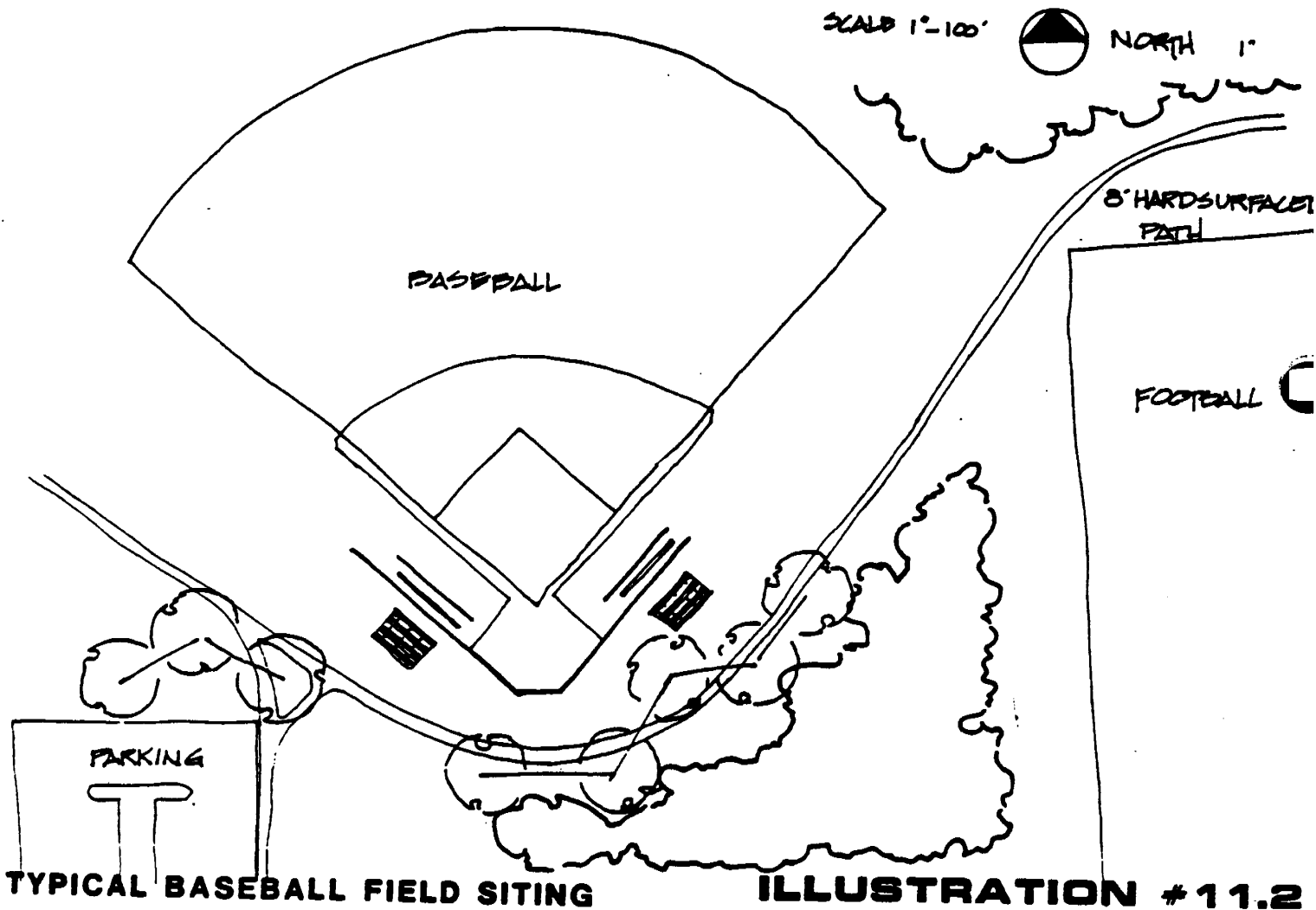

TYPICAL BASEBALL FIELD SITING

ILLUSTRATION #11.2

- 7. Pitcher Mounds - As shown on (Detail # G4)
- 8. Hoods

Hooded backstops are to be used for all baseball fields. (See Detail #G2)

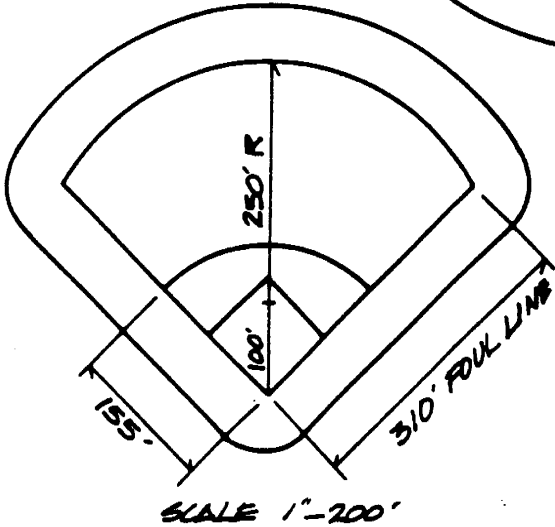
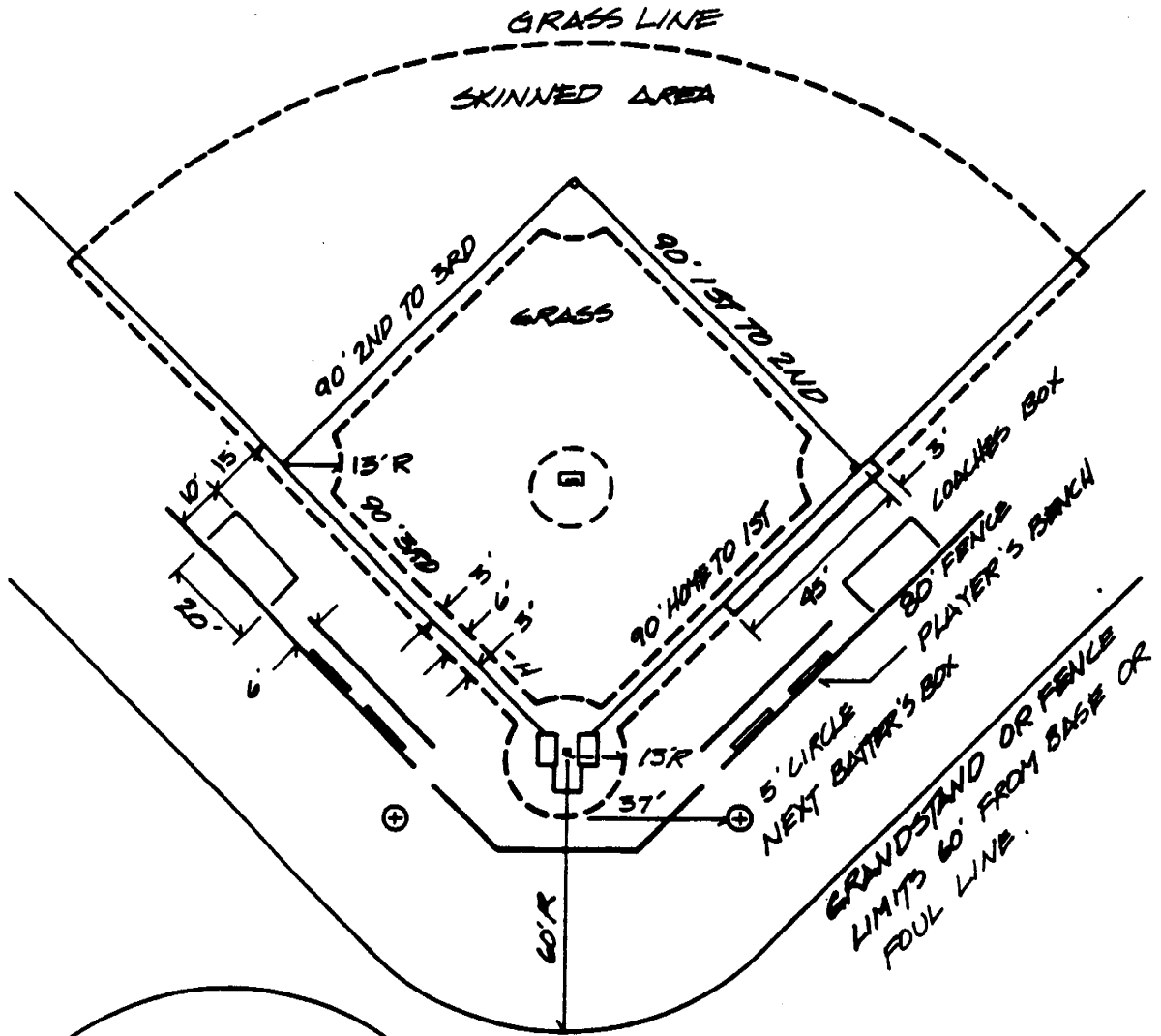

SCALE 1" = 40'

- NOTES**
1. 155' SKINNED AREA RADIUS FROM HOME PLATE.
 2. BACKSTOP MINIMUM 20' FROM HOME PLATE.

FIELD LAYOUT

BASEBALL

PARKS AND RECREATION FACILITIES GUIDELINES © MANDPPC 1983

DEPARTMENT OF PARKS & RECREATION STANDARDS & SPECIFICATIONS, Prince George's County

	Date Approved: <u>8/3/83</u>	Drawn <u>MMM</u>	Date <u>7/85</u>	Revised _____	Date _____	<p>DETAIL</p> <p>G1</p>
Division of Planning, Design & Research		MARYLAND NATIONAL CAPITAL PARK & PLANNING COMMISSION				

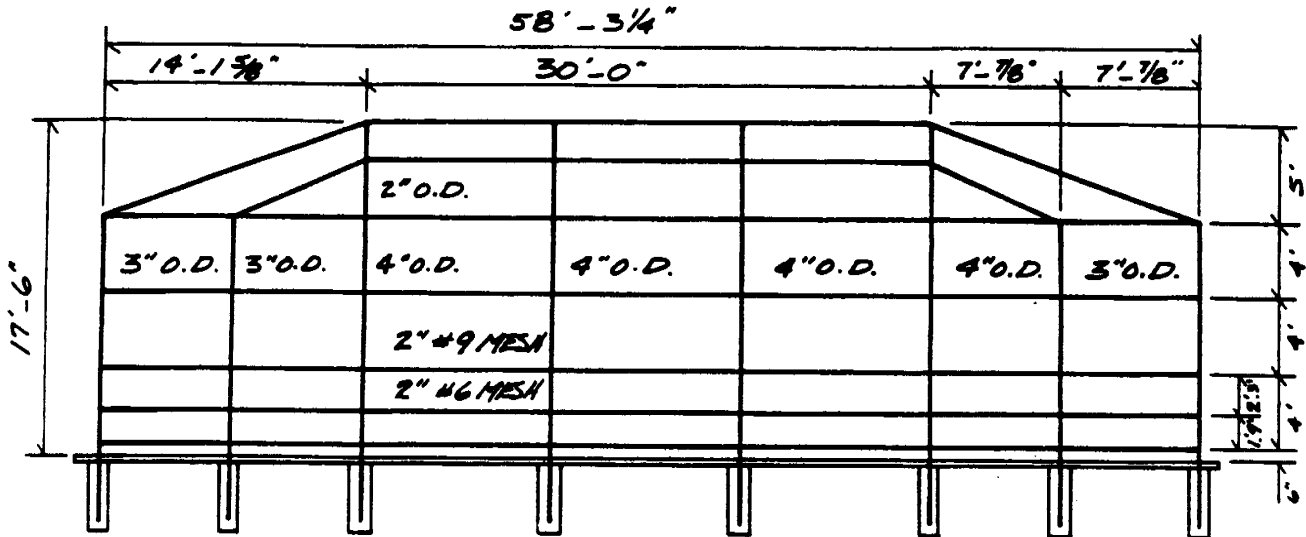
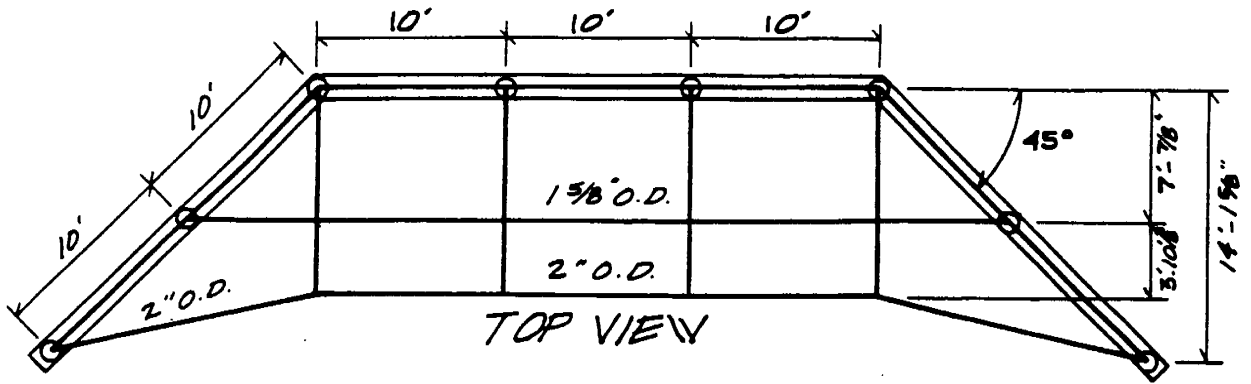

FRONT VIEW

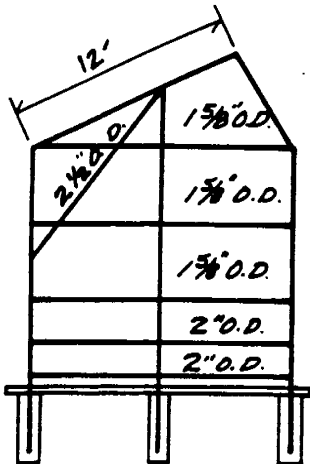

SIDE VIEW

NOTES

1. REFER TO DETAIL # G3 FOR FOOTINGS AND MOV STRIP.
2. HOODED BACKSTOP REQUIRED FOR BASEBALL.
3. FENCE END POST 2 1/2\"/>

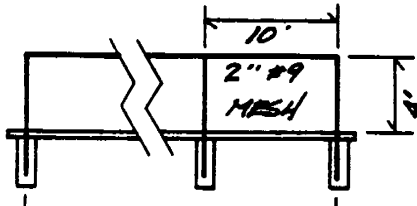

SCALE 1\"/>

HOODED BACKSTOP

BASEBALL

PARKS AND RECREATION FACILITIES
GUIDELINES © M-NPPC 1983

DEPARTMENT OF PARKS & RECREATION STANDARDS & SPECIFICATIONS, Prince George's County



Date Approved: 8/3/83
Francis E. Fuller Md. RLA # 387

Division of Planning, Design & Research

Drawn
MNM
GEF

Date
7/83

Revised	Date

MARYLAND NATIONAL CAPITAL
PARK & PLANNING COMMISSION

DETAIL
G2

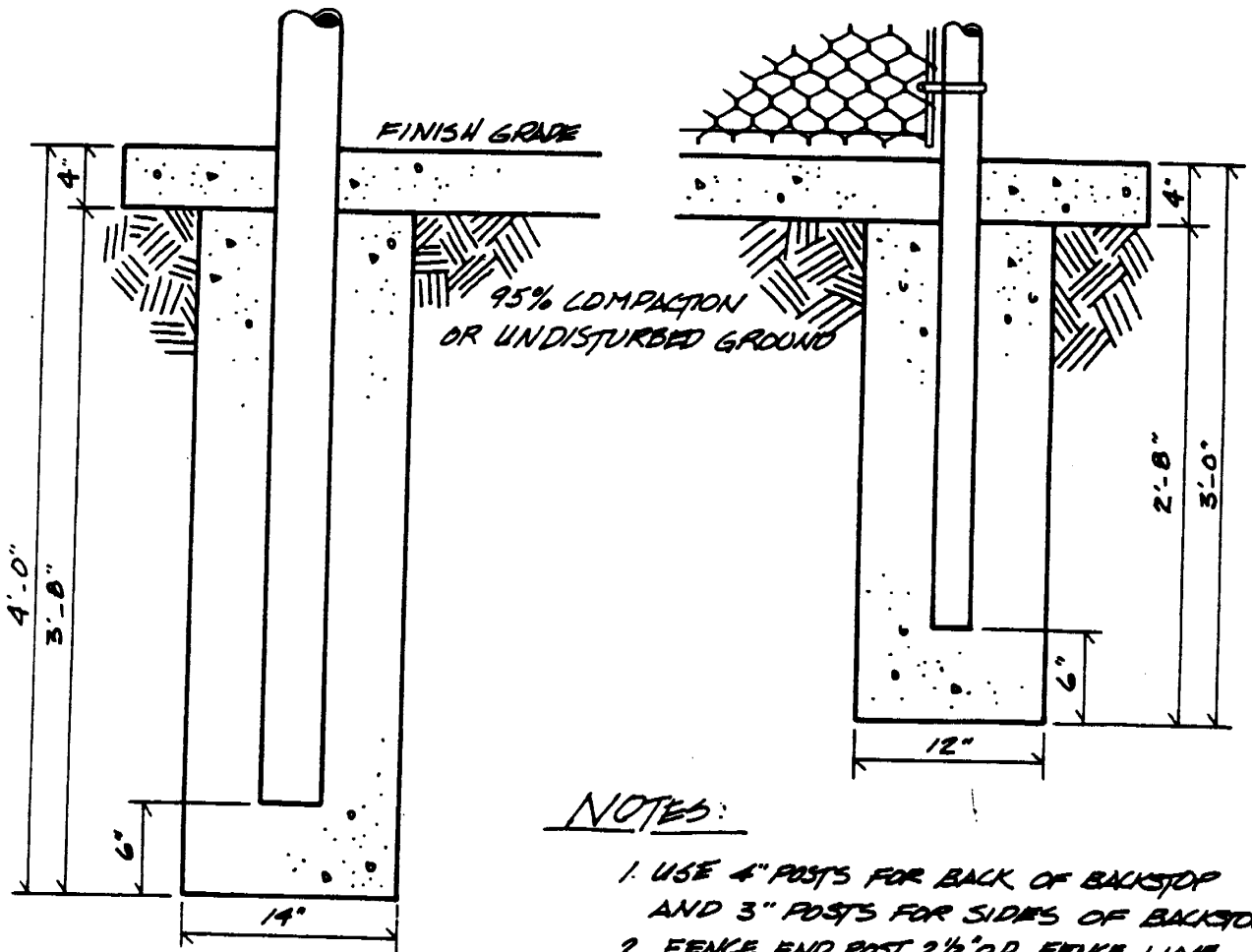
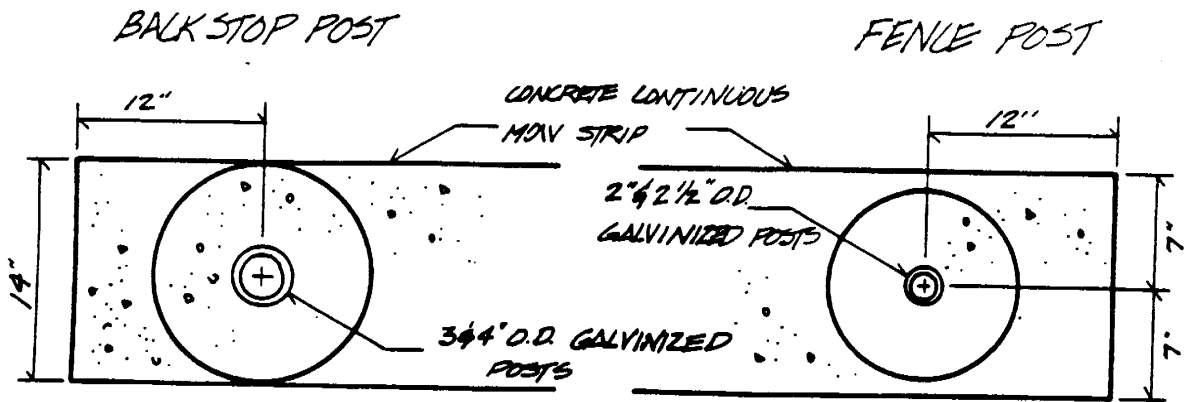

- NOTES:
1. USE 4" POSTS FOR BACK OF BACKSTOP AND 3" POSTS FOR SIDES OF BACKSTOP.
 2. FENCE END POST 2 1/2" O.D., FENCE LINE POST 2" O.D.
 3. CONCRETE (D-2 2500 PSI)

SCALE 1"=1'-0"

BACKSTOP AND FENCE POST FOOTINGS

BASEBALL

PARKS AND RECREATION FACILITIES
GUIDELINES © MNCPPC 1983

DEPARTMENT OF PARKS & RECREATION STANDARDS & SPECIFICATIONS, Prince George's County



Date Approved: 8/3/83
Frank E. Fidler M.D. P.L.A. # 387

Drawn
MINI
GWF

Date
7/83

Revised

Date

DETAIL

G3

Division of Planning, Design & Research

MARYLAND NATIONAL CAPITAL
PARK & PLANNING COMMISSION

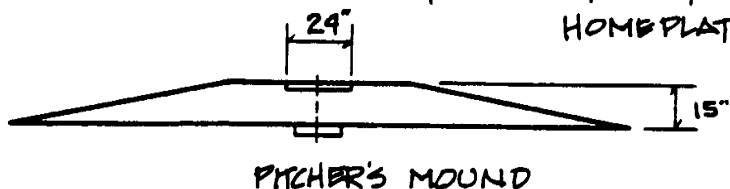
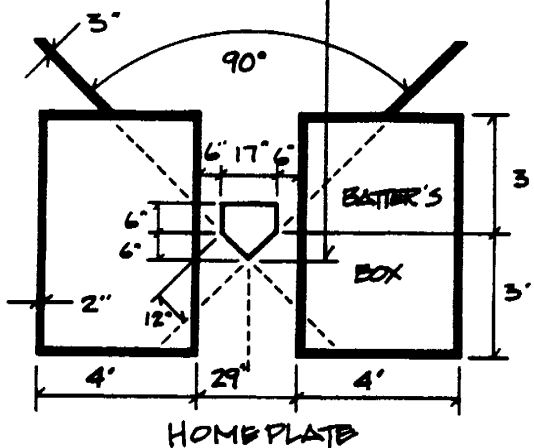
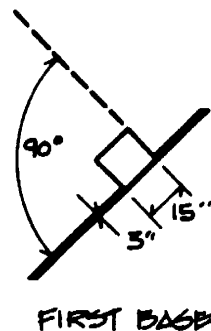
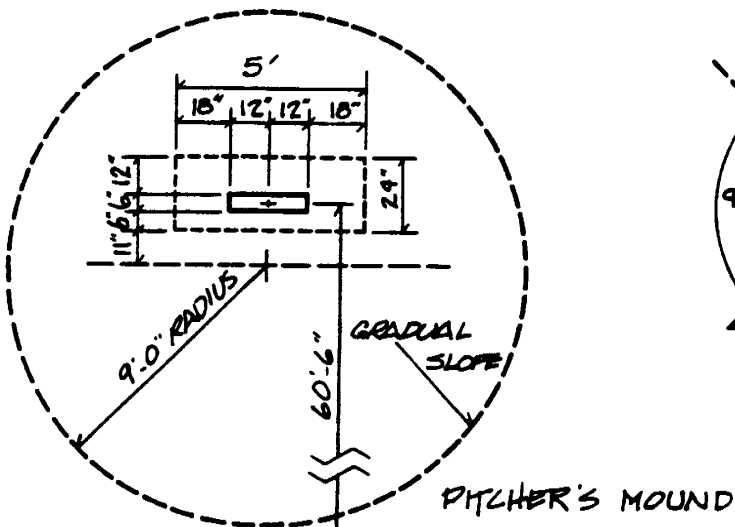
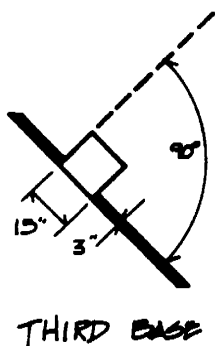
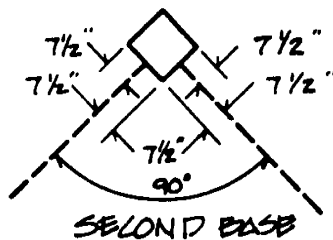

SCALE 1"=5'-0"

BASE LAYOUT

BASEBALL

PARKS AND RECREATION FACILITIES
GUIDELINES © MNCPPC 1983

DEPARTMENT OF PARKS & RECREATION STANDARDS & SPECIFICATIONS, Prince George's County



Date Approved: 8/3/83

Grace E. Fullen M.D. RIA #387

Division of Planning, Design & Research

Drawn
MNM
GFP

Date
7-83

Revised	Date

DETAIL

G4

MARYLAND NATIONAL CAPITAL
PARK & PLANNING COMMISSION

FIRST PREFERENCE
2% SLOPE

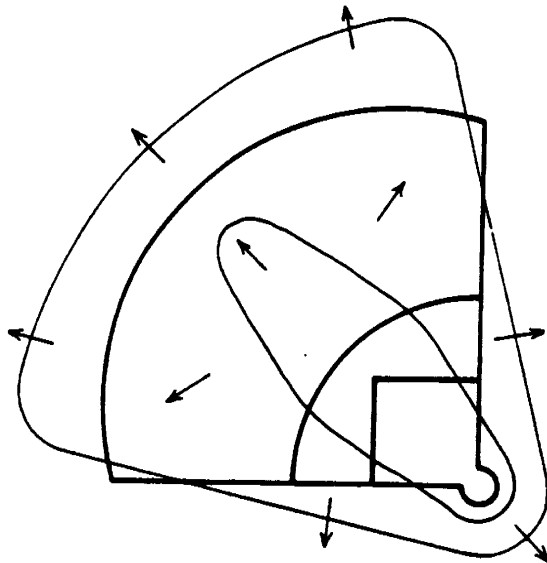
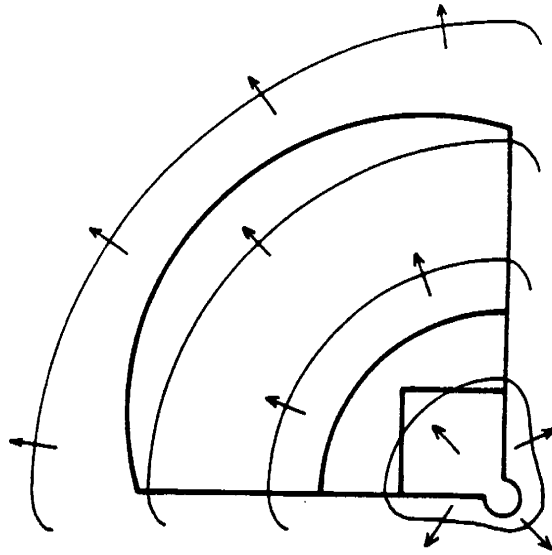

SECOND PREFERENCE
2% SLOPE

SCALE 1" = 160'

DRAINAGE

BASEBALL

PARKS AND RECREATION FACILITIES
GUIDELINES © 11-10/PPC 1983

DEPARTMENT OF PARKS & RECREATION STANDARDS & SPECIFICATIONS, Prince George's County



Date Approved: 8/3/83

Quinn E. Fillion Md. RLA # 387

Division of Planning, Design & Research

Drawn
MNM
GEF

Date
7/83

Revised _____ Date _____

MARYLAND NATIONAL CAPITAL
PARK & PLANNING COMMISSION

DETAIL

G5

PLETNER MOORE

9. Foul Line Fences

Foul line fences (Detail #G1) are to be used on all baseball fields.

10. Benches

Player benches (Detail #G1) are to be installed behind foul line fences for all fields. (Fields will be programmed for league play.)

11. Skinned Area

Special soil mix 1/3 clay, 1/3 sand, 1/3 topsoil is to be placed in infield. See specifications.

DESIGN OPTIONS

Suggested Addition to Improve Facilities

Shading

If heavy use of field(s) is anticipated, an area for spectator seating should be provided that is shaded. This can be in several forms:

1. A landscaped grass hill.
2. Bleacher with shade trees planted in proximity.
3. Architectural covering - awnings, lath, hoods, canopies, etc.

Trees sited near fields should have 3 guys per tree, 120° apart the first branch should be high enough to clear the top of the head of a person standing on the bleacher or a hill. Recommend 2-1/2" to 3" caliper minimum.

PLAN REQUIREMENTS

Written Specifications and Construction Details

Written specifications and details follow that are provided for the construction of baseball fields. All fields are to be constructed in accordance with these specifications and details.

Preliminary Plat and Comprehensive Design Plan Requirements

The preliminary plat/comprehensive design plan is to indicate the location of the baseball field and its relationship to paths, property lines, parking and other recreational facilities.

Site Plan and Specific Design Plan Requirements

1. Site grading
2. Spot elevations
3. Landscaping
4. Paths
5. Buffers
6. Setback lines
7. Seating

Detail Sheet Requirements

1. Layout
2. Fencing
3. Entrances
4. Written Specifications
5. Cross sections
6. Plan view

CONSTRUCTION SPECIFICATIONS

1. SCOPE

The contract work to be performed under this section consists of all the required labor, material, equipment, and services necessary to complete excavation and site work, as shown on drawings prepared by the applicant. It includes excavating, pumping, backfilling and rough grading to elevations shown for completion of work, as hereinafter specified.

2. CLEARING SITE

The site development plan shows areas to be cleared.

(a) Clearing:

(1) Limits of clearing shall be confined to those areas as shown on the plans or as required by the typical grading and paving sections. The clearing line is to be marked in field by contractor. Activity by the Contractor beyond these limits shall be at the authorization of the Engineer and/or Landscape Architect. At several locations, the grading may have to vary slightly to avoid destruction of specimen trees.

(2) Clearing shall include demolition and removal of all trees, saplings, brush, downed timber, shrubs, rotten wood, rubbish, vines, undergrowth, and any other vegetation from the area of game courts, walkways, and facilities. Clearing shall also include other trees as shown on the plans and so designated for removal. Demolition shall include the root system of trees, as well as the removal of fences and incidental structures.

(b) Grubbing:

(1) Limits of grubbing shall coincide with limits of clearing, unless otherwise specified.

(2) Grubbing shall include removing from the ground all stumps, roots and stubs, brush, organic materials, and debris within the limits of grubbing.

(c) Disposal:

(1) Burning of materials on site shall not be permitted.

(2) Where chips are to be utilized on a site the trees may be chipped.

The following generally pertains to parkland development:

(3) All trees shall be thoroughly chipped and used as mulch on site. Chipped material shall be stockpiled on site as shown on the plans.

(4) Maximum size chipped particles shall be three inches (3") in any dimension.

(d) General:

(1) The Contractor shall visit the site to determine the existing conditions and shall be held responsible for all demolition covered under these specifications.

(2) The Contractor's attention is specifically directed to the Maryland Department of Transportation Specifications, Section 31.01-12, Subparagraphs 1 and 7, referring to tree trimming and scar repairs.

(e) Field Quality Control:

(1) The Engineer and/or Landscape Architect shall approve the clearing line prior to any clearing.

(2) After clearing and grubbing has been completed, the Engineer shall inspect damage to remaining trees and shall direct the contractor to repair damage by a professional tree surgery firm at no expense to the Owner.

(f) Demolition on Site:

(1) Protection to Persons and Property: All work shall be scheduled and executed in a careful manner with due consideration for workmen and the public, in order to prevent injury to any persons or property.

(2) Use of Explosives: Do not do any blasting on the project site without written permission of the Engineer and unless it is done in accordance with applicable laws and regulations.

(g) Clean-Up:

(1) Remove from the site any stumps, dead trees, broken and loose branches, rubbish, and debris resulting from demolition, unless otherwise specified.

(2) Leave the site in a safe, clean condition.

(3) After demolition and removal work is completed, do not store on site any materials resulting from demolition or any tools and equipment used for work.

3. GRADING

The grading plan shows the extent of areas to be graded. All grades shall be in accordance with plans.

- (a) Soil Tests: Soil tests have not been made to determine the characteristics of the soil and the level of the water table except as shown on the plans.
- (b) Subsurface Conditions: The Contractor is to examine information shown on the plans, and is to examine the site, making such tests as he deems necessary to determine the conditions and nature of the soil.
- (c) Bench Marks and Monuments: Carefully maintain all benchmarks, monuments and other reference points. If disturbed or destroyed, replace as directed.
- (d) Finished Grades: Refer to the required grade elevations indicated. If finished grades shown by spot elevations conflict with those shown by contours, spot elevations shall be used. Unless indicated, the project site area shall be given uniform slopes between points for which finished grades are shown, or between such points and existing established grade, except vertical curves or roundings shall be provided at abrupt changes in slope. Do all grading required to bring the entire project area to finished grades.
- (e) Debris: Remove from the site all debris and excavated material not suitable, or not needed for fill.

4. SITE DRAINAGE

1. GENERAL

See Site Development Plan.

2. SCOPE

The contract work to be performed under this section consists of all the required labor, material, equipment, and services necessary to complete site drainage, as shown on the drawings.

5. TOPSOIL, SEEDING, AND SOD

(2) Scope:

- (1) Sodding and seeding are to be as included in the contract.
- (2) The contract work to be performed under this section consists of all the required labor, material, equipment, and services necessary to install topsoil, as shown on the drawings or as specified herein.
- (3) The smallest practical area of land is to be exposed at any one time during development.

- (4) Make provisions to effectively accommodate the increased runoff caused by changed soil and surface conditions during development.
- (5) Natural vegetation must be retained and protected.
- (6) The permanent final vegetation and structures must be installed as soon as practical in the development of this site.

(b) Topsoil:

- (1) Stripped topsoil is to be reasonably free of woody plants, stones over one inch (1") in size, construction debris, excavated material, and deleterious matter.
- (2) Topsoil is to be approved by the Engineer and/or Landscape Architect before installation and is to consist of a sandy loam containing 2 to 2.5 organic matter free of debris, rock, and gravel.
- (3) Furnish and spread four inches (4") of topsoil over disturbed areas.
- (4) Spread evenly to true contours and hand rake to an even, smooth surface ready for seeding.
- (5) Regrade and fill low spots after shrinkage.
- (6) Existing topsoil, if acceptable, may be used as far as it will go. New topsoil is to be brought in as necessary to build up required grading. Any tests required to determine quality of topsoil, both existing and new, will be made where, and as directed by the Engineer and/or Landscape Architect, at no expense to the Owner.

(c) Seeding:

- (1) Grass seed shall be Maryland State Certified and mixed in the following percentages by weight:

<u>SEED</u>	<u>PERCENT OF MIX</u>	<u>PERCENT GERMINATION</u>	<u>PERCENT PURITY</u>	<u>PERCENT WEED SEED CONTENT</u>
Kentucky Bluegrass	10	75	85	.40
K-31 Tall Fescue	90	85	98	.50

(2) Seeding Operation

Seed shall be sown at the rate of 6-8 lbs./1,000 square feet or 250 lbs./acre.

The seed shall be spread by mechanical spreaders at the rate previously specified. Seeding shall be done in two directions, the second being perpendicular to the first using one-half of the amount of seed in each direction. The seed shall be in firm contact with the seed bed and raked into the top one-fourth inch (1/4") of topsoil. The contractor shall have the option of rolling the seed into the topsoil, rather than raking. If the contractor elects to roll, the roller shall weigh no more than 150 pounds.

- (2) Fertilizer shall be a commercial chemical fertilizer, 50% of the nitrogen of which is derived from natural organic sources of ureaform. The fertilizer shall contain the following percentages by weight:

20% nitrogen
20% phosphoric acid
10% potash

Fertilizer shall be applied at the rate of 220 pounds per acre to the areas to be seeded sodded.

- (3) Ground Limestone shall conform to MSHA, Article 20.05, Section 20.05-3.

- (4) In no event shall more than forty-eight (48) hours elapse between the cutting and planting of the sod.

- (5) Water shall be clean and potable, suitable for drinking.

- (6) Straw Mulch shall consist of thoroughly threshed wheat, rye, or oat straw.

- (7) Binder Terra Tac AR or approved equal.

- (8) SOD

Sod shall be cultivated bluegrass-fescue mixture grown in an established turf nursery for at least two (2) years before lifting. Sod shall be free of insects, grubs, and apparent disease, and shall show proof of a current Nursery Inspection Certificate.

- (1) Sod shall have been mowed prior to stripping and shall have been maintained for a minimum of three (3) months at or near the height of final clipping at the nursery. Maximum height: two and one-half inches (2-1/2").

- (2) Sod shall be machine striped at a uniform soil thickness of approximately one inch (1"), plus-or-minus one-quarter inch (1/4"). Though thinner cuts tend to accelerate knitting and are, therefore, preferred, the minimum acceptable soil thickness shall be three-quarter inch (3/4"). Measurement for thickness shall include the growth and thatch.

(3) Individual pieces of sod shall be cut to the supplier's standard width and length. (Maximum allowable deviation from standard width and length is five (5) percent.) There shall be no broken pads, torn or uneven ends.

(4) In no event shall more than forty-eight (48) hours elapse between the cutting and planting of the sod.

(5) Before placing sod upon any surface, all shaping and dressing of such surfaces shall have been completed to grades on the plan. The completed areas to be sodded shall present a smooth, uniform, well tilled surface, and any raking required to accomplish this shall be done immediately prior to the placing of the sod.

(6) Sodding shall be performed during the proper season for such work. No frozen sod shall be used, and no sod shall be placed upon frozen soil.

(7) Maintenance - Sod shall be kept moist until it has become established, and its continued growth assured, or until accepted.

(8) Slopes - On slopes two-to-one (2:1) and steeper, sod shall be laid with the long edges parallel to the contour starting at the bottom of the slope. Succession strips shall be neatly matched, and all joints staggered or broken. When placing sod in drainage ditches, the length of the strip shall be laid parallel to the direction of the flow of the water.

(9) Each strip or section of sod placed on slopes two-to-one (2:1) and steeper, and surface drainage V-shaped or flat bottom ditches or gutters, shall be staked securely with at least two (2) stakes spaced not more than two feet (2') apart with the flat side against the slope. Stakes may be wood wedges and shall be 1/2" x 1" x 12" to 1/2" x 1" x 15" driven flush with the top of the sod.

(10) Guarantee - Sodded areas which do not show a prompt catch shall be resodded at no expense to the Owner.

(6) MULCHING

The mulch shall be applied over the seeded areas in an approved manner. The rate of application shall average 115 pounds per 1,000 square feet with a minimum of 90 pounds and a maximum of 140 pounds per 1,000 square feet so as to provide a loose depth of not less than one and one-half inches (1-1/2") nor more than three inches (3").

Uniform distribution and depth of mulch must be obtained. After the mulch is in place, all mulched surfaces shall be sprayed with asphalt binder material so that the surface has a uniform appearance. The binder shall be applied to the mulch at the rate of eight (8) gallons per 1,000 square feet. A spray nozzle of approved design shall be used. The nozzle shall be operated at a distance of not less than four feet (4') from the surface of the mulch. A pump or air compressor of adequate capacity shall be used to insure uniform distribution of the bituminous material.

(7) TIME OF SEEDING AND SODDING

March 1 to May 1 and August 1 to October 31, inclusive.

(8) SKINNED AREA (Arrangements may be made with DPR to complete the skinned area after finished grade is established).

Skinned area is to be covered with a soil mix of 1/3 coarse sand, 1/3 topsoil and 1/3 clay that is well mixed, free and clear of all mud seed, debris, branch or root matter, rock and stone.

Soil mix to be placed on field in "turtle back" with high point at pitcher's mound that is 6 to 8" higher than finished grades, feathering to 1" on the outer edges of the infield. Placement is to be followed by hand raking.

(9) MAINTENANCE

The contractor shall maintain all seeded and sodded areas for a period of not less than 45 days nor more than 60 days. Maintenance shall consist of watering, weeding, mowing, repairing of all erosion and settlement, and reseeding or resodding of lawn areas, as necessary, to establish a weed-free, dense, closely knit turf of the grasses specified.

At the time of the first mowing, mower blades shall be set between two and two and one-half inches (2-2-1/2"). All newly seeded and sodded areas shall receive at least three (3) mowings before acceptance of lawns. Remove all grass clippings during or immediately after mowing.

Maintenance shall also include any temporary protection fences, barriers, and signs, as well as all other work incidental to proper maintenance.

SOCCER FIELD

A soccer field should be built in areas where there is a strong interest in soccer and organized leagues. A soccer field requires approximately 1-1/2 acres. Soccer is popular with all age groups of male and female teams in addition to co-ed teams. In areas where there are a lot of youth leagues the "youth field" will provide additional play fields on less acreage but it is not a substitute for a regulation size field.

DESIGN REQUIREMENTS

1. Required - None

2. Size

Soccer Field - 225'x360' (Detail # H1)

Youth Field - 150' x 240' (Detail # H2)

Orientation

Directly north/south

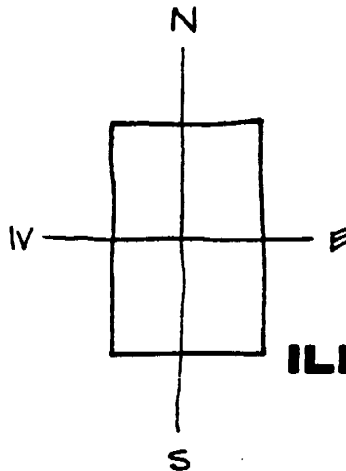

ORIENTATION

ILLUSTRATION #12.1

4. Overlapping

Not recommended (If combination field is desired, see football/soccer combination).

5. Siting

Football/soccer field combinations are not to be sited in, on, or under any of the following:

- a. 100 year floodplain
- b. Power lines;
- c. Manholes;
- d. Goal posts are not to be placed on any easements;
- e. Fields are to be set back a minimum of 100 feet for access roads and property;
- f. Fields are to be a minimum of 75' feet from any other field or facility.

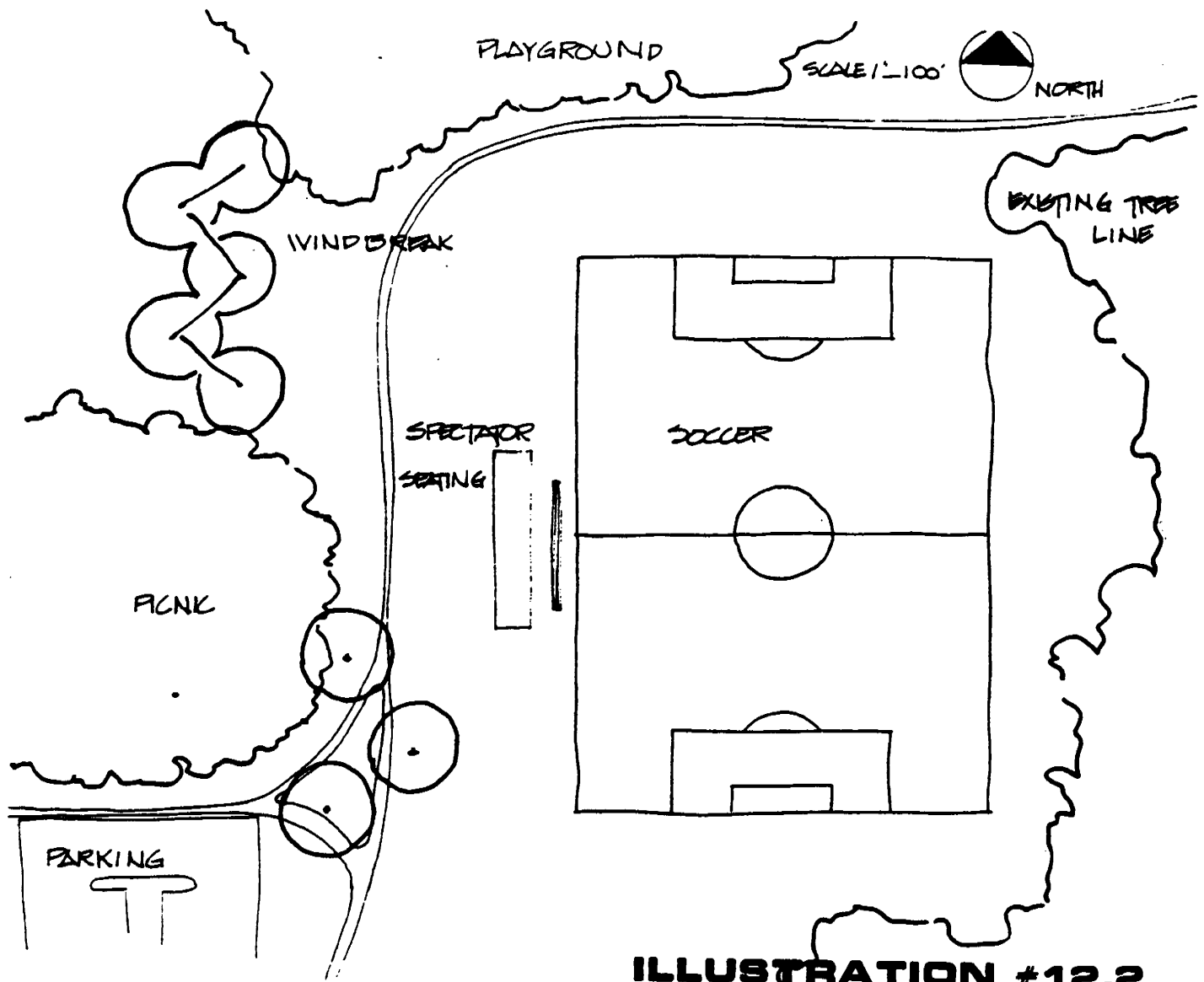

ILLUSTRATION #12.2

TYPICAL SOCCER FIELD SITING

- 6. Drainage (Detail #H4) Minimum 2% slope, positive drainage.
- 7. Goal Post - Two (2) stand and goals required for either end of the field. Pins may be set up to allow removal at end of season.

DESIGN OPTIONS

Suggested Additions to Improve Facilities

A soccer field planned for a park that is programmed for league play must have seating.

- A. Player Bench Placement - (See Detail #H1). Seat should be wooden with galvanized legs anchored in concrete. team seating may be on opposite sides or on the same side of the field.

Amount of Seating

Soccer teams have approximately 20 players per team (including managers, coaches, etc).

2/3 of players on the bench at once (14x24"/player)=28' of seating per team (may be provided with any length of bench).

Team benches per facility = 56' of seating

This length of bench shall accommodate all age groups of play and both sexes.

Spectator Seating - Provision of seating for spectators and the amount of seating needed is dependent upon the following factors that the designer will have to weigh:

- A. Type of games to be played (i.e. regular season playoffs, championships);
- B. Type of park (sports, neighborhood, regional, community, etc.);
- C. Age of players to use field-youth leagues vs. adult.

General Rule of Thumb

It is better to provide too little seating than too much (particularly since the cost of bleachers is high). Regardless of how much seating is provided, the area should be expandable. (Detail # H 1)

Grass Seating - A grass hill (maximum 3:1 slope approximately 5' high) will provide suitable seating for lesser used parks. Inclement weather will make grass seating undesirable at times.

Shade - If heavy use of fields is anticipated, provide area(s) for spectator seating that is shaded.

Type of Shade:

1. A grass hill planted with shade trees.
2. Bleachers with shade trees planted in proximity.
3. Architectural covering, i.e. awnings, canopies, etc.

Trees site near the field should have 3 guys per tree, 120° apart. The first branch of trees should be pruned to allow free movement underneath. Trees should be a minimum of 2-1/2 to 3" caliper.

PLAN REQUIREMENTS

Preliminary Plat and Comprehensive Design Plan Requirements

The preliminary plat/comprehensive design plan is to indicate the location of the soccer field and its relationship to paths, property lines, parking and other recreational facilities.

Site Plan and Specific Design Plan Requirements

1. Site grading
2. Spots elevations
3. Landscaping
4. Paths
5. Buffers
6. Setback lines
7. Seating

Detail Sheet Requirements

1. Layout
2. Fencing
3. Written specifications
4. Cross sections
5. Plan view

CONSTRUCTION SPECIFICATIONS

1. SCOPE

The contract work to be performed under this section consists of all of the required labor, material, equipment, and services necessary to complete excavation and site work, as shown on drawings prepared by the applicant. It includes excavating, pumping, backfilling, and rough grading to elevations shown for completion of work, as hereinafter specified.

2. CLEARING SITE

The site development plan shows areas to be cleared.

(a) Clearing:

(1) Limits of clearing shall be confined to those areas as shown on the plans, or as required by the typical grading and paving sections. The clearing line is to be marked in the field by the Contractor. Activity by the Contractor beyond these limits shall be at the authorization of the Engineer and/or the Landscape Architect. At several locations, the grading may have to vary slightly to avoid destruction of specimen trees.

(2) Clearing shall include demolition and removal of all trees, saplings, brush, downed timber, shrubs, rotten wood, rubbish, vines, undergrowth, and any other vegetation from the area of game courts, walkways, and facilities. Clearing shall also include other trees as shown on the plans and so designated for removal. Demolition shall include the root systems of trees, as well as the removal of fences and incidental structures.

(b) Grubbing:

(1) Limits of grubbing shall coincide with limits of clearing, unless otherwise specified.

(2) Grubbing shall include removing from the ground all stumps, roots and stubs, brush, organic materials, and debris within the limits of grubbing.

(c) Disposal:

(1) Burning of materials on site shall not be permitted.

(2) Where chips are to be utilized on a site the trees may be chipped.

The following generally pertain to parkland development:

(3) All trees shall be thoroughly chipped and used as mulch on-site. Chipped material shall be stockpiled on site as shown on the plans.

(4) The maximum size of chipped particles shall be three inches (3") in any dimension.

(d) General:

(1) The Contractor shall visit the site to determine the existing conditions and shall be held responsible for all demolition covered under these specifications.

(2) The Contractor's attention is specifically directed to the Maryland Department of Transportation's Specifications, Section 31.01-12, Subparagraphs 1 and 7, referring to tree trimming and scar repairs.

(e) Field Quality Control:

(1) The Engineer and/or Landscape Architect shall approve the clearing line prior to any clearing.

(2) After clearing and grubbing has been completed, the Engineer and/or Landscape Architect is to inspect damage to remaining trees and shall direct the contractor to have the damage repaired by a professional tree surgery firm at no expense to the Owner.

(f) Demolition on Site:

(1) Protection to Persons and Property: All work shall be scheduled and executed in a careful manner with due consideration for workmen and the public, and to prevent injury to any persons or property.

(2) Use of Explosives: Do not do any blasting on the project site without written permission of the Engineer and unless it is done in accordance with applicable laws and regulations.

(g) Clean-Up:

(1) Remove from the site any stumps, dead trees, broken and loose branches, rubbish, and debris resulting from demolition, unless otherwise specified.

(2) Leave the site in a safe, clean condition.

(3) After demolition and removal work is completed, do not store on site any materials resulting from demolition or any tools and equipment used for work.

3. GRADING

The grading plan shows the extent of areas to be graded. All grades shall be in accordance with plans.

- (a) Soil Tests: Soil tests have not been made to determine the characteristics of the soil and the level of the water table, except as shown on the plans.
- (b) Subsurface Conditions: The Contractor is to examine information shown on the plans, and is to examine the site, making such tests as he deems necessary to determine the conditions and nature of the soil.
- (c) Bench Marks and Monuments: Carefully maintain all benchmarks, monuments, and other reference points. If disturbed or destroyed, replace as directed.
- (d) Finished Grades: Refer to the required grade elevations indicated. If finished grades shown by spot elevations conflict with those shown by contours, spot elevations shall be used. Unless indicated, the project site area shall be given uniform slopes between points for which finished grades are shown, or between such points and existing established grade, except vertical curves or roundings which shall be provided at abrupt changes in slope. Do all grading required to bring the entire project area to finished grades.
- (e) Debris: Remove from the site all debris and excavated material not suitable, or not needed for fill.

4. SITE DRAINAGE

1. GENERAL

See Site Development Plan.

2. SCOPE

The contract work to be performed under this section consists of all the required labor, material, equipment, and services necessary, to complete site drainage, as shown on the drawings.

5. TOPSOIL, SEEDING AND SOD

(a) Scope:

- (1) Sodding and seeding are to be as included in the contract.
- (2) The contract work to be performed under this section consists of all the required labor, material, equipment, and services are to be provided as necessary to install topsoil, as shown on the drawings or as specified herein.
- (3) The smallest practical area of land is to be exposed at any one time during development.

- (4) Make provisions to effectively accommodate the increased runoff caused by changed soil and surface conditions during development.
- (5) Natural vegetation must be retained and protected.
- (6) The permanent final vegetation and structures must be installed as soon as practical in the development of this site.

(b) Topsoil:

- (1) Stripped topsoil is to be reasonably free of woody plants, stones over one inch (1") in size, construction debris, excavated material, and deleterious matter.
- (2) Topsoil is to be approved by the Engineer and/or Landscape Architect before installation, and is to consist of a sandy loam containing 2 to 2.5 organic matter free of debris, rock, and gravel.
- (3) Furnish and spread four inches (4") of topsoil over disturbed areas.
- (4) Spread evenly to true contours and hand rake to an even, smooth surface ready for seeding.
- (5) Regrade and fill low spots after shrinkage.
- (6) Existing topsoil, if acceptable, may be used as far as it will go. New topsoil is to be brought in, as necessary, to build up required grading. Any tests required to determine the quality of topsoil, both existing and new, will be made where, and as directed, by the Engineer and/or Landscape Architect, at no expense to the Owner.

(c) Seeding:

- (1) Grass seed shall be Maryland State Certified and mixed in the following percentages by weight:

<u>SEED</u>	<u>PERCENT OF MIX</u>	<u>PERCENT GERMINATION</u>	<u>PERCENT PURITY</u>	<u>PERCENT WEED SEED CONTENT</u>
Kentucky Bluegrass	50	75	85	.40
K-31 Tall Fescue	90	85	98	.50

(2) Seeding Operations

The seed shall be spread by mechanical spreaders at the rate previously specified. Seeding shall be done in two directions, the second being perpendicular to the first using one-half of the amount of seed in each direction. The seed shall be in firm contact with the seed bed and raked into the top one-fourth inch (1/4") of topsoil. The contractor shall have the option of rolling the seed into the topsoil, rather than raking. If the contractor elects to roll, the roller shall weigh no more than 150 pounds.

Seed shall be sown at the rate of 6-8 lbs./1,000 square feet, or 250 pounds per acre.

- (2) Fertilizer shall be a commercial chemical fertilizer 50% of the nitrogen of which is derived from natural organic sources of ureaform. The fertilizer shall contain the following percentages by weight:

20% nitrogen
20% phosphoric acid
10% potash

Fertilizer shall be applied at the rate of 220 pounds per acre to the areas to be seeded sodded.

- (3) Ground Limestone shall conform to MSHA, Article 20.05, Section 20.05-3.

- (4) In no event shall more than forty-eight (48) hours elapse between the cutting and planting of the sod.

- (5) Water shall be clean and potable, suitable for drinking.

- (6) Straw Mulch shall consist of thoroughly threshed wheat, rye, or oat straw.

- (7) Binder Terra Tac AR or approved equal.

- (d) Sod:

Sod shall be cultivated bluegrass-fescue mixture grown in an established turf nursery for at least two (2) years before lifting. Sod shall be free of insects, grubs, and apparent disease, and shall show proof of a current Nursery Inspection Certificate.

- (1) Sod shall have been mowed prior to stripping and shall have been maintained for a minimum of three (3) months at or near the height of final clipping at the nursery. Maximum height: two and one-half inches (2-1/2").

- (2) Sod shall be machine stripped at a uniform soil thickness of approximately one inch (1"), plus-or-minus one-quarter inch (1/4"). Though thinner cuts tend to accelerate knitting and are, therefore, preferred, the minimum acceptable soil thickness shall be three-quarter inch (3/4). Measurement for thickness shall include the growth and thatch.

(3) Individual pieces of sod shall be cut to the supplier's standard width and length. (Maximum allowable deviation from standard width and length is five (5) percent.) There shall be no broken pads, torn or uneven ends.

(4) In no event shall more than forty-eight (48) hours elapse between the cutting and planting of the sod.

(5) Before placing sod upon any surface, all shaping and dressing of such surfaces shall have been completed to grades on the plan. The completed areas to be sodded shall present a smooth, uniform, well tilled surface, and any raking required to accomplish this shall be done immediately prior to the placing of the sod.

(6) Sodding shall be performed during the proper season for such work. No frozen sod shall be used, and no sod shall be placed upon frozen soil.

(7) Maintenance - Sod shall be kept moist until it has become established, and its continued growth assured, or until accepted.

(8) Slopes - On slopes two-to-one (2:1) and steeper, sod shall be laid with the long edges parallel to the contour starting at the bottom of the slope. Succession strips shall be neatly matched, and all joints staggered or broken. When placing sod in drainage ditches, the length of the strip shall be laid parallel to the direction of the flow of the water.

(9) Each strip or section of sod placed on slopes two-to-one (2:1) and steeper, and surface drainage V-shaped or flat bottom ditches or gutters, shall be staked securely with at least two (2) stakes spaced not more than two feet (2') apart with the flat side against the slope. Stakes may be wood wedges and shall be 1/2" x 1" x 12" to 1/2" x 1" x 15" driven flush with the top of the sod.

(10) Guarantee - Sodded areas which do not show a prompt "catch" shall be resodded at no expense to the Owner.

(6) MULCHING

The mulch shall be applied over the seeded areas in an approved manner. The rate of application shall average 115 pounds per 1,000 square feet, with a minimum of 90 pounds and a maximum of 140 pounds per 1,000 square feet, so as to provide a loose depth of not less than one and one-half inches (1-1/2") nor more than three inches (3").

Uniform distribution and depth of mulch must be obtained. After the mulch is in place, all mulched surfaces shall be sprayed with asphalt binder material so that the surface has a uniform appearance. The binder shall be applied to the mulch at the rate of eight (8) gallons per 1,000 square feet. A spray nozzle of approved design shall be used. The nozzle shall be operated at a distance of not less than four feet (4') from the surface of the mulch. A pump or air compressor of adequate capacity shall be used to insure uniform distribution of the bituminous material.

(7) TIME OF SEEDING AND SODDING

March 1 to May 1 and August 1 to October 31, inclusive.

(8) MAINTENANCE

The Contractor shall maintain all seeded and sodded areas for a period of not less than 45 days nor more than 60 days. Maintenance shall consist of watering, weeding, mowing, repairing of all erosion and settlement, and reseeding or resodding of lawn areas, as necessary, to establish a weed-free, dense, closely knit turf of the grasses specified.

At the time of the first mowing, mower blades shall be set between two and two and one-half inches (2-2-1/2"). All newly seeded and sodded areas shall receive at least three (3) mowings before acceptance of lawns. Remove all grass clippings during or immediately after mowing.

Maintenance shall also include any temporary protection fences, barriers, and signs, as well as all other work incidental to proper maintenance.

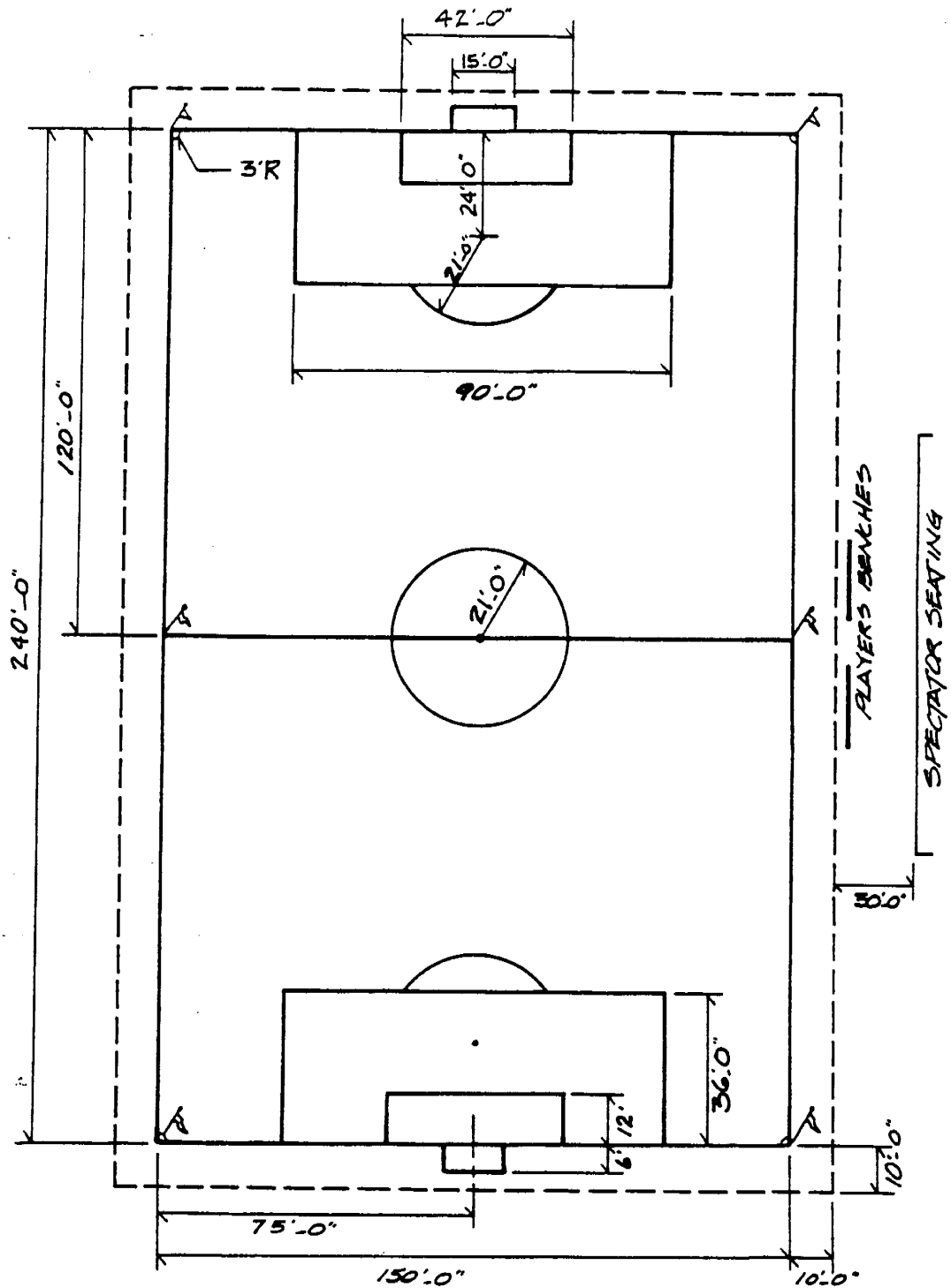

SCALE: 1" = 40'

CHILDREN'S FIELD LAYOUT

SOCCER

PARKS AND RECREATION FACILITIES
GUIDELINES © MNCPPC 1983

DEPARTMENT OF PARKS & RECREATION STANDARDS & SPECIFICATIONS, Prince George's County



Date Approved: 8/3/83

Gene E. Fidler Md. P.L.A. #387

Division of Planning, Design & Research

Drawn
MANN/GEF

Date
7/83

Revised

Date

MARYLAND NATIONAL CAPITAL
PARK & PLANNING COMMISSION

DETAIL
H2

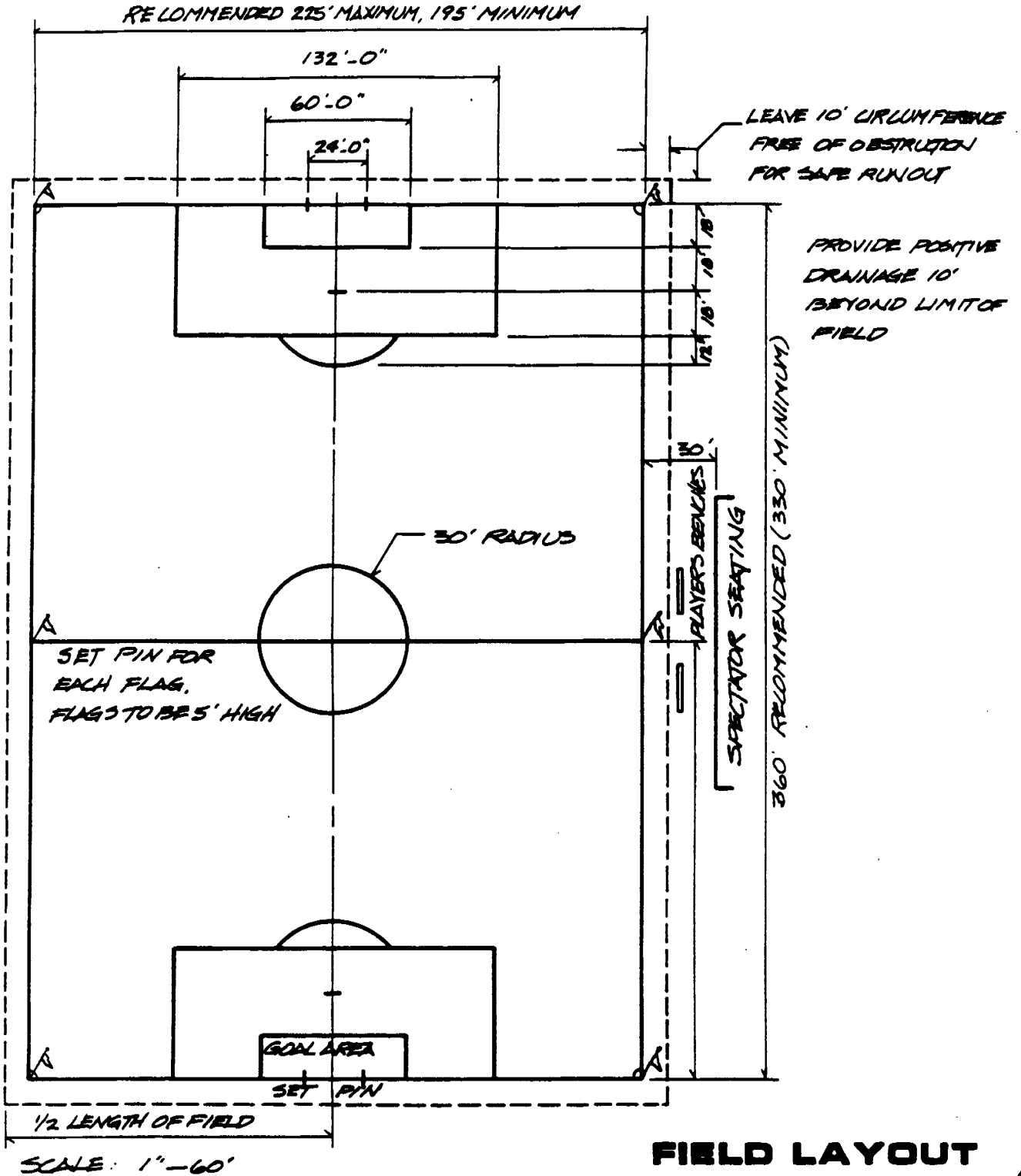

SOCCKER

PARKS AND RECREATION FACILITIES
GUIDELINES © M-NDPPC 1983

DEPARTMENT OF PARKS & RECREATION STANDARDS & SPECIFICATIONS, Prince George's County



Date Approved: 8/3/83

Jane E. Fuller Hd. P.L.A. #387

Drawn
M/M
G/F

Date
7/83

Revised

Date

DETAIL

H1

Division of Planning, Design & Research

MARYLAND NATIONAL CAPITAL
PARK & PLANNING COMMISSION

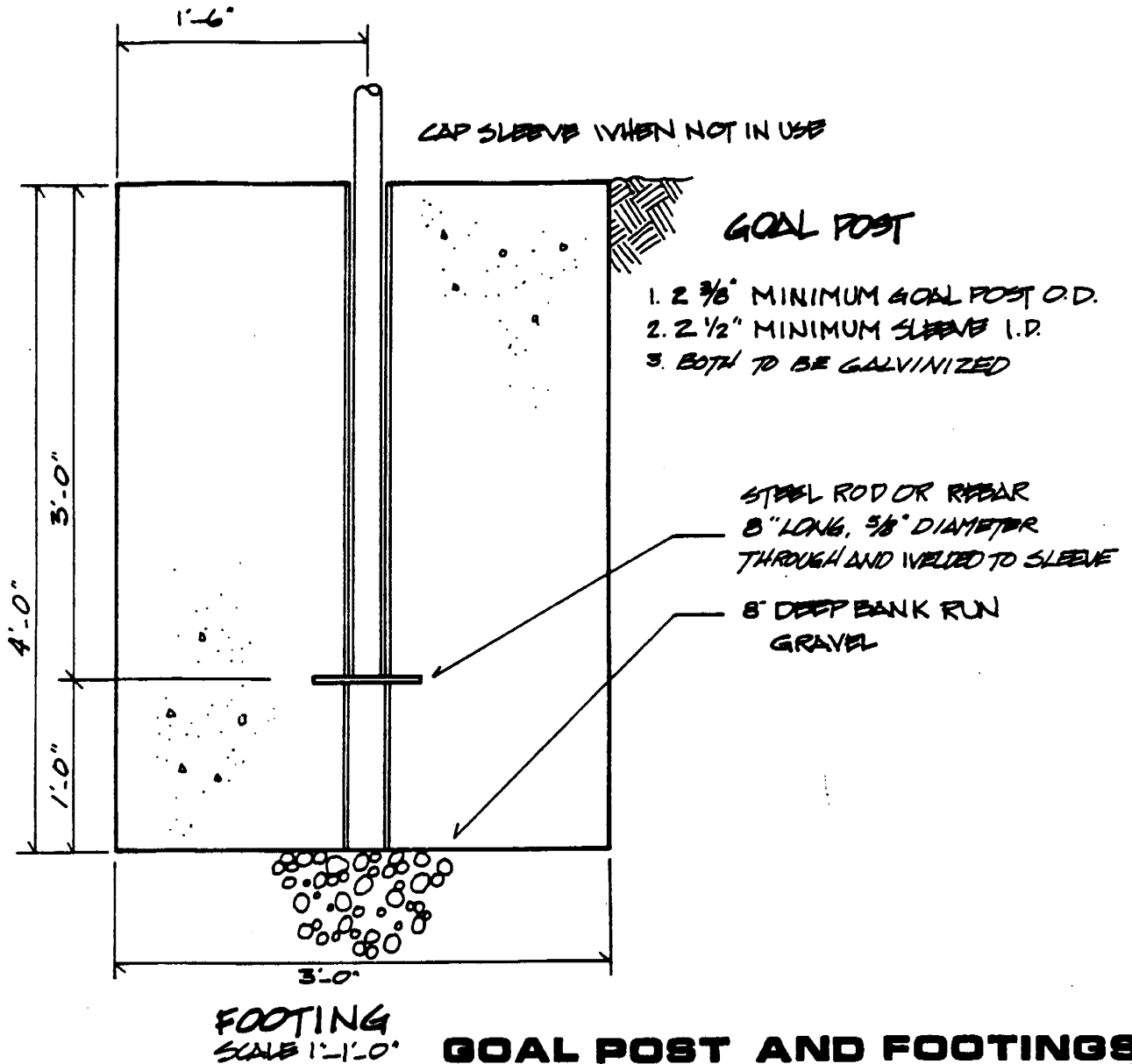
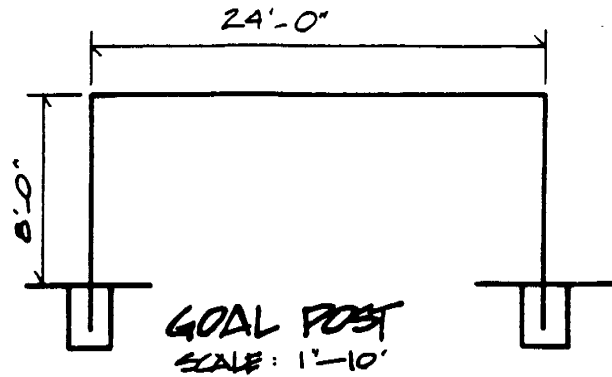

PARKS AND RECREATION FACILITIES
GUIDELINES © MNCPPC 1983

SOCCKER

DEPARTMENT OF PARKS & RECREATION STANDARDS & SPECIFICATIONS, Prince George's County



Date Approved: 6/3/83

James E. Fidler, Md. P.L.A. #357

Division of Planning, Design & Research

Drawn
MNM
GEF

Date
7/83

Revised

Date

MARYLAND NATIONAL CAPITAL
PARK & PLANNING COMMISSION

DETAIL

H3

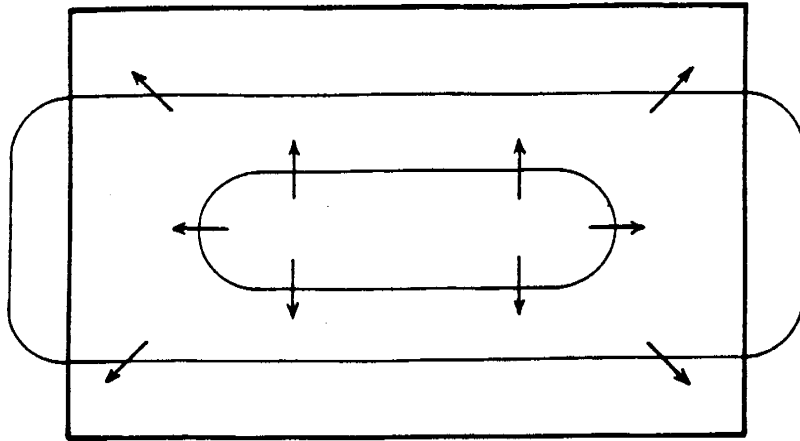

SIDE

NOTES:

1. USE CROSS FIELD IN STEEP AREA AND ON COMBINATION FIELDS (SOFTBALL/SOCCER).
2. 2% SLOPE

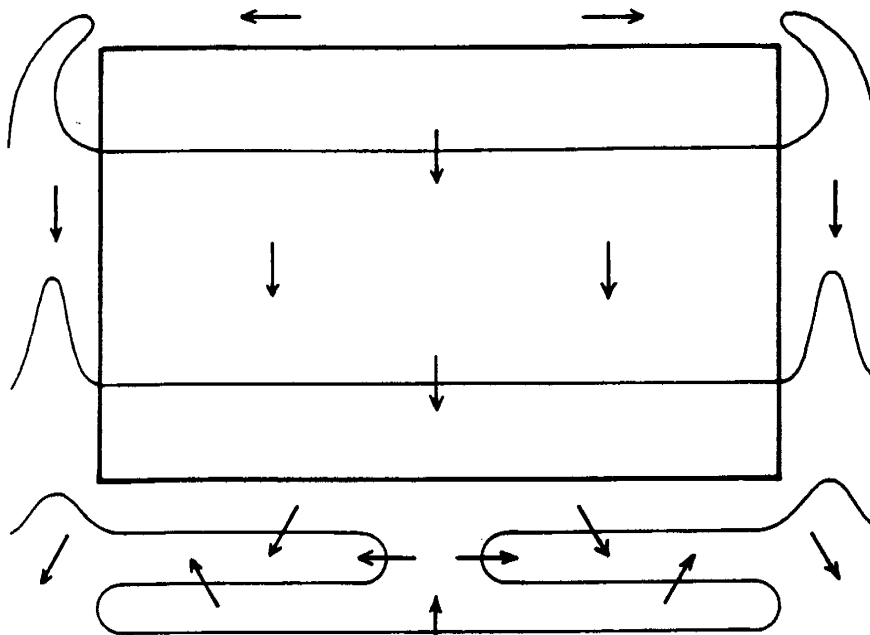

CROSS FIELD

SCALE: 1"=100'

DRAINAGE

SOCCER

PARKS AND RECREATION FACILITIES
GUIDELINES © M-NDPPC 1983

DEPARTMENT OF PARKS & RECREATION STANDARDS & SPECIFICATIONS, Prince George's County



Date Approved: 2/3/83

James E. Fidler Md. RLA #387

Division of Planning, Design & Research

Drawn
MNM
GF

Date
7/83

Revised

Date

MARYLAND NATIONAL CAPITAL
PARK & PLANNING COMMISSION

**DETAIL
H4**

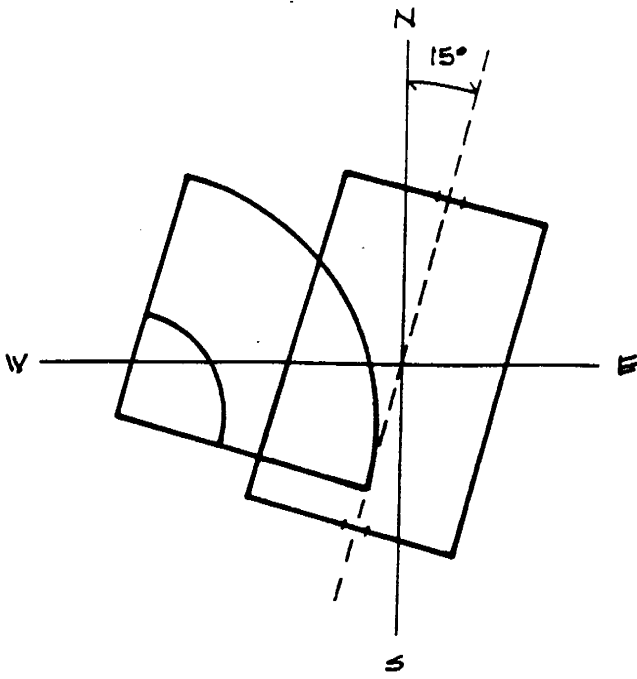

NOTES:

1. GOAL POSTS MAY REMAIN THROUGHOUT THE YEAR.
2. ORIENT SOCCER 15° N.E.
3. SITE SOCCER OUTSIDE 110' SKINNED AREA.
4. DO NOT USE FOUL LINE OR OUTFIELD FENCING ON SOFTBALL.

KEY

□ PRIMARY FIELD

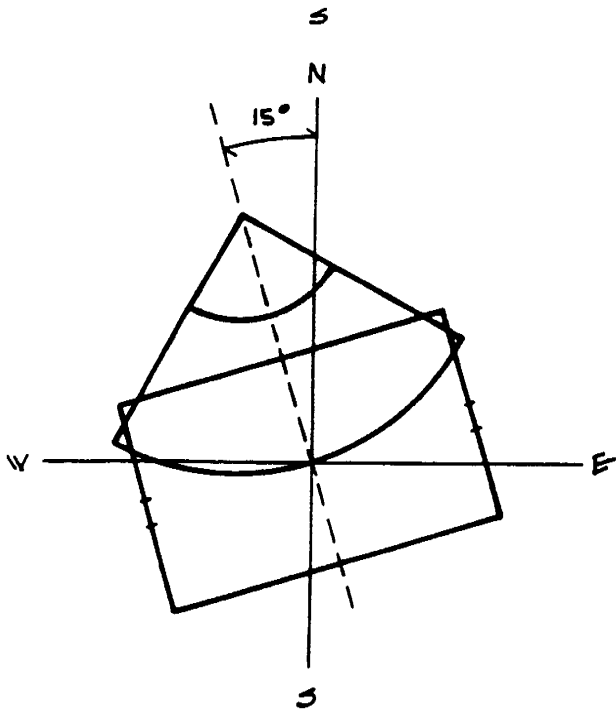

NOTES:

1. GOAL POSTS MUST BE REMOVED AT END OF SEASON.
2. ORIENT SOFTBALL 15° N.W.
3. SITE SOCCER FIELD BEYOND 110' SKINNED AREA.
4. DO NOT USE FOUL LINE OR OUTFIELD FENCING ON SOFTBALL.

SCALE 1"=100'

COMBINATION FIELD OVERLAYS

SOCCER

PARKS AND RECREATION FACILITIES
GUIDELINES © M-NOPPC 1983

DEPARTMENT OF PARKS & RECREATION STANDARDS & SPECIFICATIONS, Prince George's County



Date Approved: 8/3/83
Gene E. Fuller Md. RLA #387

Division of Planning, Design & Research

Drawn
MNM
GFF

Date
7/83

Revised	Date

**DETAIL
H5**

MARYLAND NATIONAL CAPITAL
PARK & PLANNING COMMISSION

SOCCKER/FOOTBALL FIELD

A football/soccer field combination should be used in areas of restricted acreage or as required by the subdivision populations. The combination field does not offer an ideal playing field for either football or soccer, and the combination field is harder to maintain and receive more wear and tear from programmed league play.

A combination football/soccer field is to be provided at the rate of 1 per 3,000 persons in a proposed subdivision. The population of the subdivision is based on a per unit figure from the Planning Department, multiplied by the proposed number of dwelling units.

Unit type x person/unit type=projected population.

A combination football/ soccer field may be sited singularly, or as a part of a major recreation area.

DESIGN REQUIREMENTS

1. Required

1 - combination football/soccer field with combination goal posts per 3,000 persons.

2. Size

325' x 360' football/soccer field combination with combination goal. Detail #11

3. Orientation

Directly north south to 20° northeast.

ORIENTATION

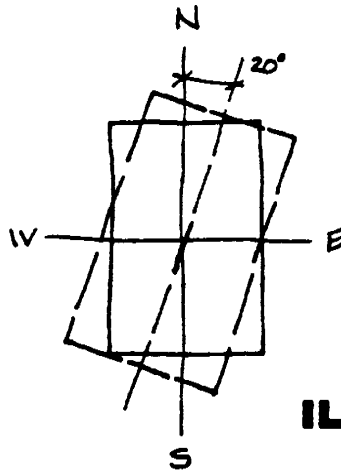

ILLUSTRATION # 13.1

4. Overlapping

The football/soccer field combination may be overlapped with a softball field. When these two fields are overlapped, the football/soccer field is to be free and clear of the softball skinned area (or area to be skinned) and backstop. The combination goal post is to be outside the area of play for softball. (Detail #14).

5. Siting

Football/soccer field combinations are not to be sited in, on, or under any of the following:

- a. 10-year floodplain;
- b. Power lines;
- c. Manholes;
- d. Goal posts are not to be placed on any easements;
- e. Fields are to be set back a minimum of 50 feet from parking lots, access drives, property lines, and or roads.

6. Drainage Detail #13

7. Goal Post

Combination football/soccer goals to be installed.

DESIGN OPTIONS

Suggested Additions to Improve Facility

A soccer field planned for a park that is programmed for league play should have seating.

Player Bench Placement - (See Detail #11). Seat should be wooden with galvanized legs anchored in concrete. Team seating may be on opposite sides or on the same side of the field.

Amount of Seating

Soccer teams have approximately 20 players per team (including managers, coaches, etc).

2/3 of players on the bench at once (12x24"/player)=28' of seating per team may be provided with any length of bench).

Team benches per facility = 56' of seating.

This length of bench shall accommodate all age groups of play and both sexes.

Spectator Seating - Provision of seating for spectators and the amount of seating needed is dependent upon the following factors that the designer will have to weigh:

- A. Type of games to be played (i.e. regular season playoffs, championships);
- B. Type of park (sports, neighborhood, regional, community, etc.);
- C. Age of players to use field-youth leagues vs. adult.

General Rule of Thumb

It is better to provide too little seating than too much (particularly since the cost of bleachers is high). Regardless of how much seating is provided, the area should be expandable. (Detail #11)

Grass Seating - A grass hill (maximum 3:1 slope approximately 5' high) will provide suitable seating for lesser used parks. Inclement weather will make grass seating undesirable at times.

If heavy use of fields is anticipated, provide an area(s) for spectator seating that is shaded.

Types of shade:

1. A grass hill planted with shade trees.
2. Bleachers with shade trees planted in proximity.
3. Architectural covering, i.e. awnings, canopies, etc.

Trees sited near the field should have 3 guys per tree, 120° apart. The first branch of trees should be pruned to allow free movement underneath. Trees should be a minimum of 2-1/2 to 3" caliper.

PLAN REQUIREMENTS

Standards and Specifications

Written specifications and details follow that are a minimum to be used in construction. Rewriting may be required for some sections to make the specifications site specific.

Preliminary Plat and Comprehensive Design Plan Requirements

The preliminary plat is to show the location of the football/soccer field(s) and its relationship to paths, property lines, parking and other recreational facilities.

Site Plan and Specific Design Plan Requirements

1. Site grading
2. Spot elevations

3. Landscaping
4. Paths
5. Buffering
6. Setback lines
7. Seating

Detail Sheet Requirements

1. Layout
2. Fencing
3. Entrances
4. Written specifications
5. Cross sections
6. Plan view

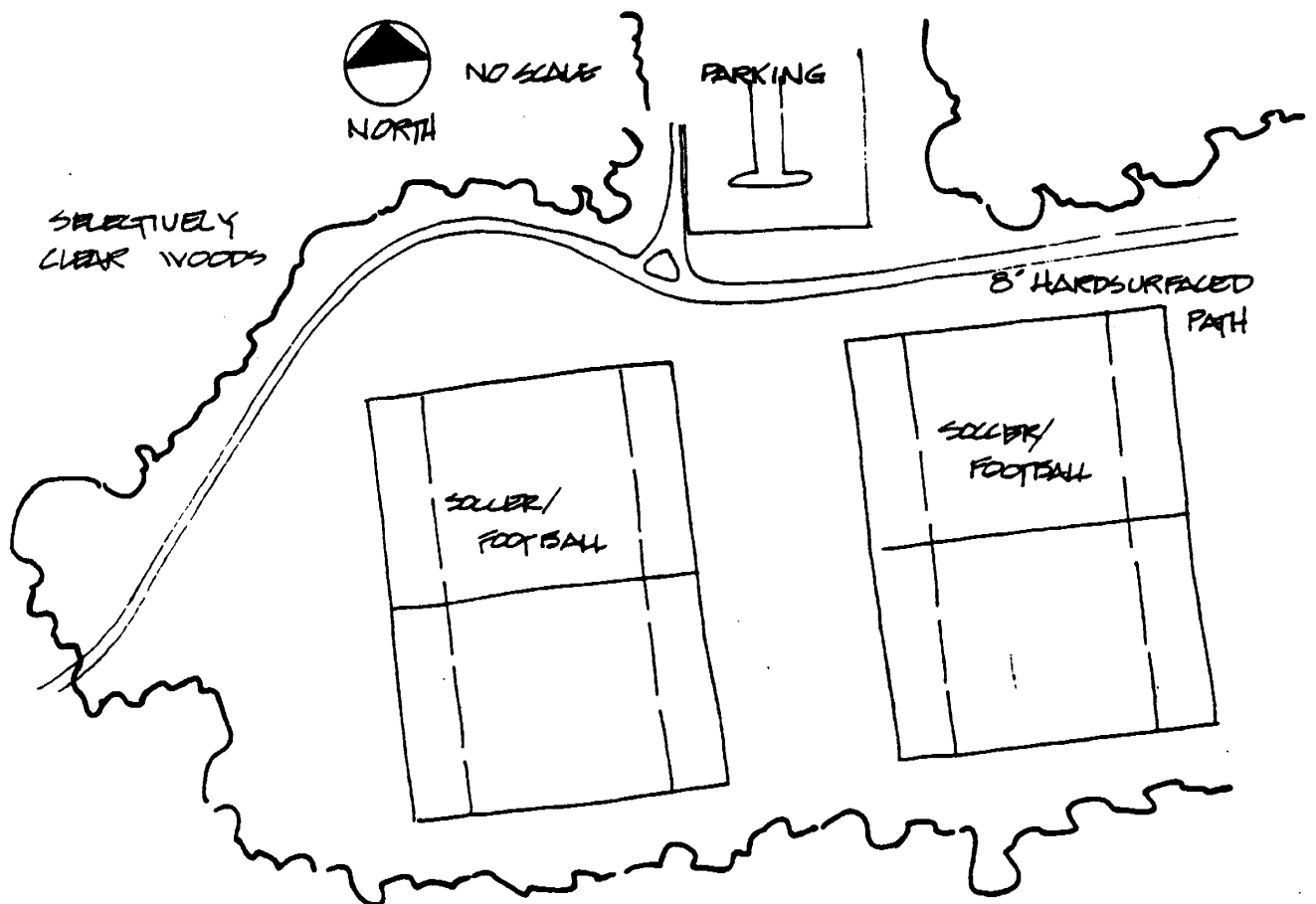

TYPICAL SOCCER/FOOTBALL FIELD SITING

ILLUSTRATION # 13.2

CONSTRUCTION SPECIFICATIONS

1. SCOPE

The contract work to be performed under this section consists of all the required labor, material, equipment and services necessary to complete excavation and site work, as shown on the drawings prepared by the applicant. It includes excavating, pumping, back filling, and rough grading to elevations shown for completion of work, as hereinafter specified.

2. CLEARING SITE

The site development plan shows areas to be cleared.

(a) Clearing:

(1) Limits of clearing shall be confined to those areas as shown on the plans, or as required by the typical grading and paving sections. The clearing line to be marked in field by the contractor. Activity by the contractor beyond these limits shall be at the authorization of the Engineer and/or Landscape Architect. At several locations, the grading may have to vary slightly to avoid destruction of specimen trees.

(2) Clearing shall include demolition and removal of all trees, saplings, brush, downed timber, shrubs, rotten wood, rubbish, vines, undergrowth, and any other vegetation from the area of game courts, walkways, and facilities. Clearing shall also include other trees as shown on the plans and so designated for removal. Demolition shall include root system of trees, as well as the removal of fences and incidental structures.

(b) Grubbing:

(1) Limits of grubbing shall coincide with limits of clearing, unless otherwise specified.

(2) Grubbing shall include removing from the ground all stumps, roots and stubs, brush, organic materials, and debris within the limits of grubbing.

(c) Disposal:

(1) Burning of materials on site shall not be permitted.

(2) Where chips are to be utilized on a site the trees may be chipped.

The following generally pertain to parkland development:

(3) All trees shall be thoroughly chipped and used as mulch on site. Chipped material shall be stockpiled on site as shown on the plans.

(4) The maximum size of chipped particles shall be three inches (3") in any dimension.

(d) General:

(1) The Contractor shall visit the site to determine the existing conditions and shall be held responsible for all demolition covered under these specifications.

(2) The Contractor's attention is specifically directed to the Maryland Department of Transportations' Specifications, Section 31.01-12, Subparagraphs 1 and 7, referring to tree trimming and scar repairs.

(e) Field Quality Control:

(1) The Engineer and/or Landscape Architect shall approve the clearing line prior to any clearing.

(2) After clearing and grubbing has been completed, the Engineer is to inspect for damage to the remaining trees and shall direct the Contractor to repair damage by using a professional tree surgery firm at no expense to the Owner.

(f) Demolition on Site:

(1) Protection to Persons and Property: All work shall be scheduled and executed in a careful manner with due consideration for workmen and the public, and to prevent injury to any persons or property.

(2) Use of Explosives: Do not do any blasting on the project site without written permission of the Engineer and unless it is done in accordance with applicable laws and regulations.

(g) Clean-Up:

(1) Remove from the site any stumps, dead trees, broken and loose branches, rubbish, and debris resulting from demolition, unless otherwise specified.

(2) Leave the site in a safe, clean condition.

(3) After demolition and removal work is completed, do not store on site any materials resulting from demolition or any tools and equipment used for work.

3. GRADING

The grading plan shows the extent of areas to be graded. All grades shall be in accordance with plans.

- (a) Soil Tests: Soil tests have not been made to determine the characteristics of the soil and the level of the water table, except as shown on the plans.
- (b) Subsurface Conditions: The contractor is to examine information shown on the plans, and is to examine the site, making such tests as he deems necessary to determine the conditions and nature of the soil.
- (c) Bench Marks and Monuments: Carefully maintain all bench marks, monuments and other reference points. If disturbed or destroyed, replace as directed.
- (d) Finished Grades: Refer to the required grade elevations indicated. If finished grades shown by spot elevations conflict with those shown by contours, spot elevations shall be used. Unless indicated, the project site area shall be given uniform slopes between points for which finished grades are shown, or between such points and existing established grade, except vertical curves or roundings shall be provided at abrupt changes in slope. Do all grading required to bring entire project area to finished grades.
- (e) Debris: Remove from the site all debris and excavated material not suitable, or not needed for fill.

4. SITE DRAINAGE

1. GENERAL

See Site Development Plan.

2. SCOPE

The contract work to be performed under this section consists of all the required labor, material, equipment and services necessary to complete site drainage, as shown on the drawings.

5. TOPSOIL, SEEDING, AND SOD

(a) Scope:

- (1) Sodding and seeding are to be as included in the contract.
- (2) The contract work to be performed under this section consists of all the required labor, material, equipment and services necessary to install topsoil, as shown on the drawings or as specified herein.
- (3) The smallest practical area of land is to be exposed at any one time during development.

- (4) Make provisions to effectively accommodate the increased runoff caused by changed soil and surface conditions during development.
- (5) Natural vegetation must be retained and protected.
- (6) The permanent final vegetation and structures must be installed as soon as practical in the development of this site.

(b) Topsoil:

- (1) Stripped topsoil is to be reasonably free of woody plants, stones over one inch (1") in size, construction debris, excavated material, and deleterious matter.
- (2) Topsoil is to be approved by the Engineer and/or Landscape Architect before installation and is to consist of a sandy loam containing 2 to 2.5 organic matter free of debris, rock, and gravel.
- (3) Furnish and spread four inches (4") of topsoil over disturbed areas.
- (4) Spread evenly to true contours and hand rake to an even, smooth surface ready for seeding.
- (5) Regrade and fill low spots after shrinkage.
- (6) Existing topsoil, if acceptable, may be used as far as it will go. New topsoil is to be brought in, as necessary, to build up required grading. Any tests required to determine the quality of topsoil, both existing and new, will be made where, and as directed, by the Engineer and/or Landscape Architect, at no expense to the Owner.

(c) Seeding:

- (1) Grass seed shall be Maryland State Certified and mixed in the following percentages by weight:

<u>SEED</u>	<u>PERCENT OF MIX</u>	<u>PERCENT GERMINATION</u>	<u>PERCENT PURITY</u>	<u>PERCENT WEED SEED CONTENT</u>
Kentucky Bluegrass	10	75	85	.40
K-31 Tall Fescue	90	85	98	.50

(2) Seeding Operations

Seed shall be sown at a rate of 6 to 8 lbs/1,000 square feet, or 250 pounds per acre.

The seed shall be spread by mechanical spreaders at the rate previously specified. Seeding shall be done in two directions, the second being perpendicular to the first using one-half the amount of seed in each direction. The seed shall be in firm contact with the seed bed and raked in to the top one-fourth inch (1/4") of topsoil. The Contractor shall have the option of rolling the seed into the topsoil, rather than raking. If the Contractor elects to roll, the roller shall weigh no more than 150 pounds.

- (2) Fertilizer shall be a commercial chemical fertilizer, 50% of the nitrogen of which is derived from natural organic sources of ureaform. The fertilizer shall contain the following percentages by weight:

20% nitrogen
20% phosphoric acid
10% Potash

Fertilizer shall be applied at the rate of 220 pounds per acre to the areas to be seeded and sodded.

- (3) Ground Limestone shall conform to MSHA, Article 20.05, Section 20.05-3.
- (4) In no event shall more than forty-eight (48) hours elapse between the cutting and planting of the sod.
- (5) Water shall be clean and potable, suitable for drinking.
- (6) Straw Mulch shall consist of thoroughly threshed wheat, rye, or oat straw.
- (7) Binder Terra Tac AR or approved equal.
- (d) Sod:

Sod shall be cultivated bluegrass-fescue mixture grown in an established turf nursery for at least two (2) years before lifting. Sod shall be free of insects, grubs, and apparent disease, and shall show proof of a current Nursery Inspection Certificate.

(1) Sod shall have been mowed prior to stripping and shall have been maintained for a minimum of three (3) months at or near the height of final clipping at the nursery. Maximum height: two and one-half inches (2-1/2").

(2) Sod shall be machine stripped at a uniform soil thickness of approximately one inch (1") , plus-or-minus one-quarter inch (1/4"). Though thinner cuts tend to accelerate knitting and are, therefore, preferred, the minimum acceptable soil thickness shall be three-quarter inch (3/4"). Measurement for thickness shall include the growth and thatch.

(3) Individual pieces of sod shall be cut to the supplier's standard width and length. (Maximum allowable deviation from standard width and length is five (5) percent). There shall be no broken pads, torn or uneven ends.

(4) In no event shall more than forty-eight (48) hours elapse between the cutting and planting of the sod.

(5) Before placing sod upon any surface, all shaping and dressing of such surfaces shall have been completed to grades on plan. The completed areas to be sodded shall present a smooth, uniform, well tilled surface, and any raking required to accomplish that shall be done immediately prior to the placing of the sod.

(6) Sodding shall be performed during the proper season for such work. No frozen sod shall be used, and no sod shall be placed upon frozen soil.

(7) Maintenance - Sod shall be kept moist until it has become established, and its continued growth assured, or until accepted.

(8) Slopes - On slopes two-to-one (2:1) and steeper, sod shall be laid with the long edges parallel to the contour starting at the bottom of the slope. Succession strips shall be neatly matched, and all joints staggered or broken. When placing sod in drainage ditches, the length of the strip shall be laid parallel to the direction of the flow of the water.

(9) Each strip or section of sod placed on slopes two-to-one (2:1) and steeper, and surface drainage V-shaped or flat bottom ditches or gutters, shall be staked securely with at least two (2) stakes spaced not more than two feet (2') apart with the flat side against the slope. Stakes may be wood wedges and shall be 1/2" x 1" x 12" to 1/2" x 1" x 15" driven flush with the top of the sod.

(10) Guarantee - Sodded areas which do not show a prompt catch shall be resodded at no expense to the Owner.

(6) MULCHING

The mulch shall be applied over the seeded areas in an approved manner. The rate of application shall average 115 pounds per 1,000 square feet, with a minimum of 90 pounds and a maximum of 140 pounds per 1,000 square feet, so as to provide a loose depth of not less than one and one-half inches (1-1/2") nor more than three inches (3").

Uniform distribution and depth of mulch must be obtained. After the mulch is in place, all mulched surfaces shall be sprayed with asphalt binder material so that the surface has a uniform appearance. The binder shall be applied to the mulch at the rate of eight (8) gallons per 1,000 square feet. A spray nozzle of approved design shall be used. The nozzle shall be operated at a distance of not less than four feet (4') from the surface of the mulch. A pump or air compressor of adequate capacity shall be used to insure uniform distribution of the bituminous material.

(7) TIME OF SEEDING AND SODDING

March 1 to May 1 and August 1 to October 31, inclusive.

(8) MAINTENANCE

The Contractor shall maintain all seeded and sodded areas for a period of not less than 45 days nor more than 60 days. Maintenance shall consist of watering, weeding, mowing, repairing of all erosion and settlement, and reseeding or resodding of lawn areas, as necessary, to establish a weed-free, dense, closely knit turf of the grasses specified.

At the time of the first mowing, mower blades shall be set between two and two and one-half inches (2-2-1/2"). All newly seeded and sodded areas shall receive at least three (3) mowings before acceptance of lawns. Remove all grass clippings during or immediately after mowing.

Maintenance shall also include any temporary protection fences, barriers, and signs, as well as all other work incidental to proper maintenance.

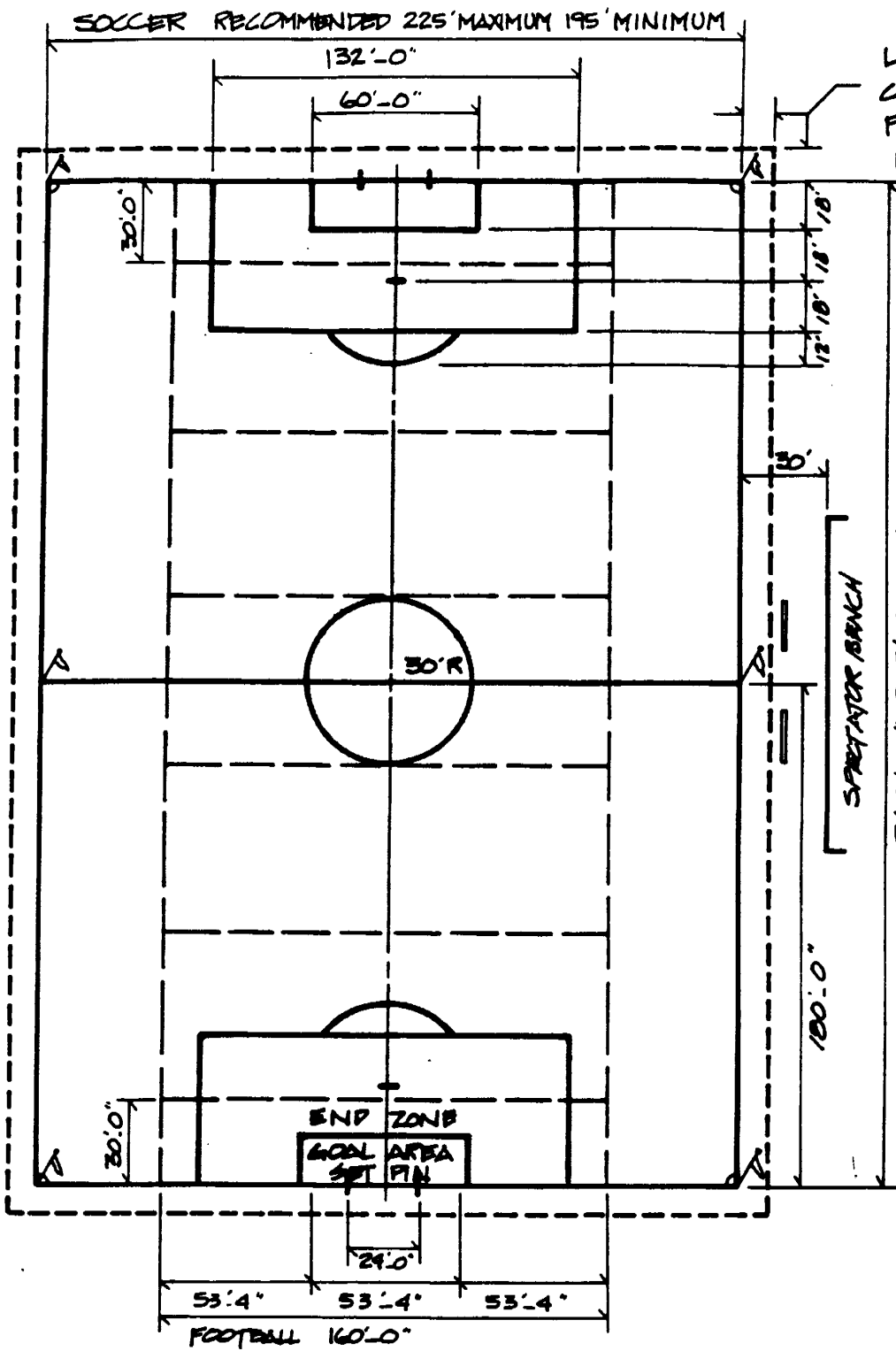

SCALE: 1" = 60'

FIELD LAYOUT

SOCCER/FOOTBALL

PARKS AND RECREATION FACILITIES
GUIDELINES © M-NDPPC 1983

DEPARTMENT OF PARKS & RECREATION STANDARDS & SPECIFICATIONS, Prince George's County



Date Approved: 0/3/83

Grace E. Fielder Md. RLA # 387

Division of Planning, Design & Research

Drawn
MNM
GEF

Date
7/83

Revised

Date

MARYLAND NATIONAL CAPITAL
PARK & PLANNING COMMISSION

DETAIL

11

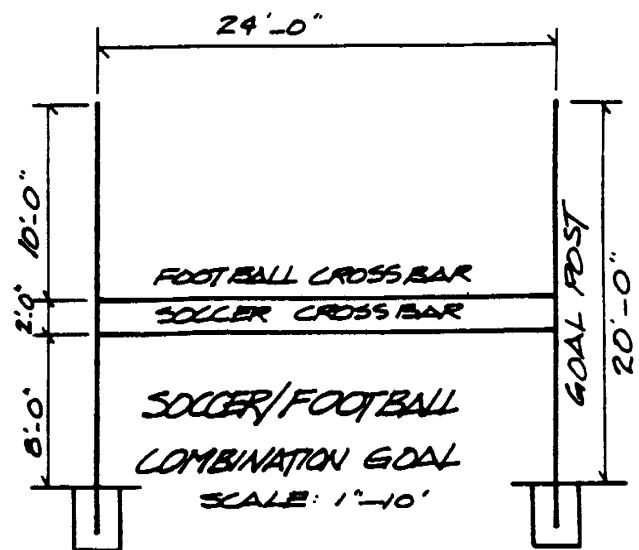

FOOTBALL CROSSBAR

SOCCER CROSSBAR

SOCCER/FOOTBALL
COMBINATION GOAL
SCALE: 1"=10'

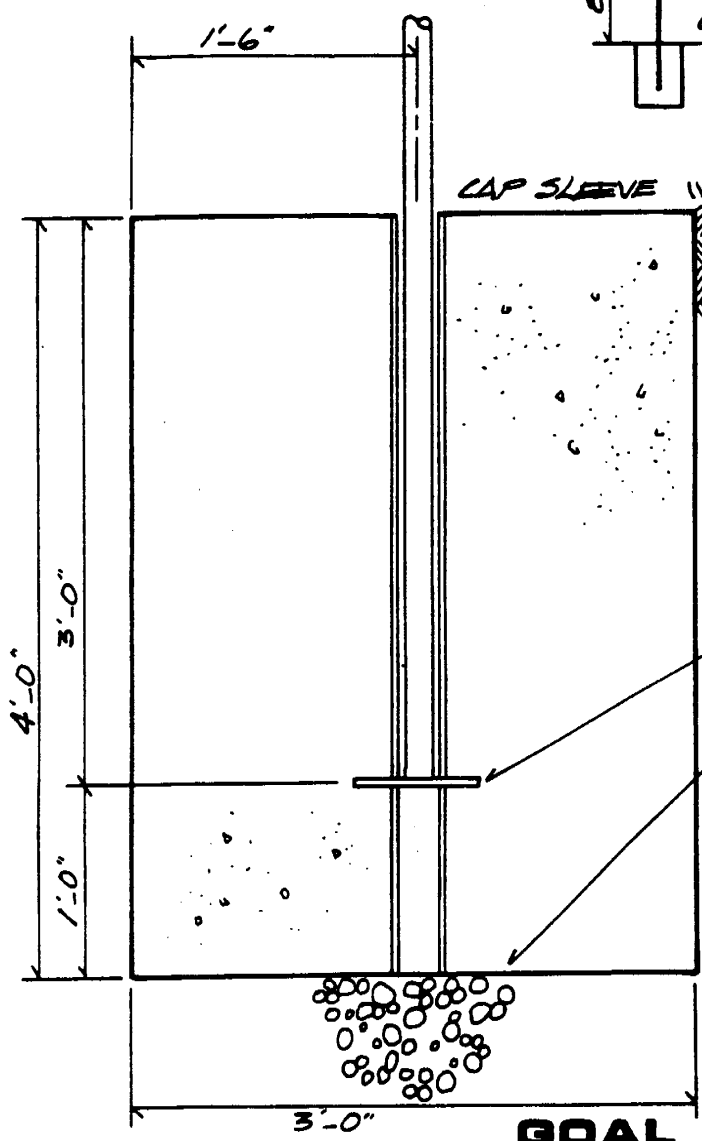

CAP SLEEVE WHEN NOT IN USE

GOAL POST

1. 2 3/8" MINIMUM GOAL POST O.D.
2. 3" MINIMUM SLEEVE I.D.
3. BOTH TO BE GALVANIZED

STEEL ROD OR REBAR 8" LONG
5/8" DIAMETER THROUGH AND
WELDED TO SLEEVE.

8" DEEP BANK RUN GRAVEL

FOOTING
SCALE: 1"=1'-0"

GOAL POST AND FOOTING

SOCCER / FOOTBALL

PARKS AND RECREATION FACILITIES
GUIDELINES © M-NCPPC 1983

DEPARTMENT OF PARKS & RECREATION STANDARDS & SPECIFICATIONS, Prince George's County



Date Approved: 2/3/83
James E. Fuller MD. RLA #387

Drawn MNM GEF	Date 7/83	Revised	Date

DETAIL
12

Division of Planning, Design & Research

MARYLAND NATIONAL CAPITAL
PARK & PLANNING COMMISSION

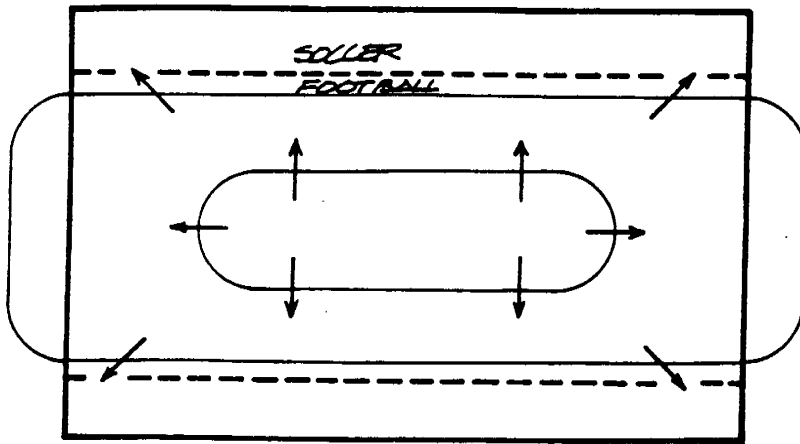

SIDE

NOTES:

- 1. USE CROSSFIELD IN ~~STEEP~~ AREA AND ON COMBINATION FIELDS (SOFTBALL/SOCCER)
- 2. 2% SLOPE

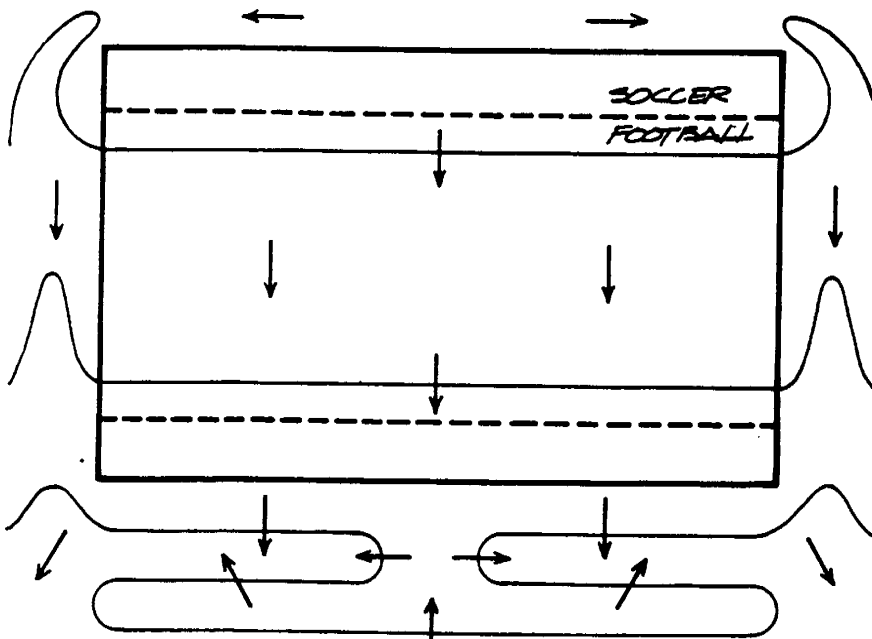

CROSS FIELD

SCALE: 1" = 100'

DRAINAGE

PARKS AND RECREATION FACILITIES
GUIDELINES © M-NCPPC 1983

SOCCER/FOOTBALL

DEPARTMENT OF PARKS & RECREATION STANDARDS & SPECIFICATIONS, Prince George's County



Date Approved: 8/3/03

James E. Feltner M.D. PLA # 387

Division of Planning, Design & Research

Drawn
MNM
GEP

Date
7/03

Revised

Date

MARYLAND NATIONAL CAPITAL
PARK & PLANNING COMMISSION

DETAIL

13

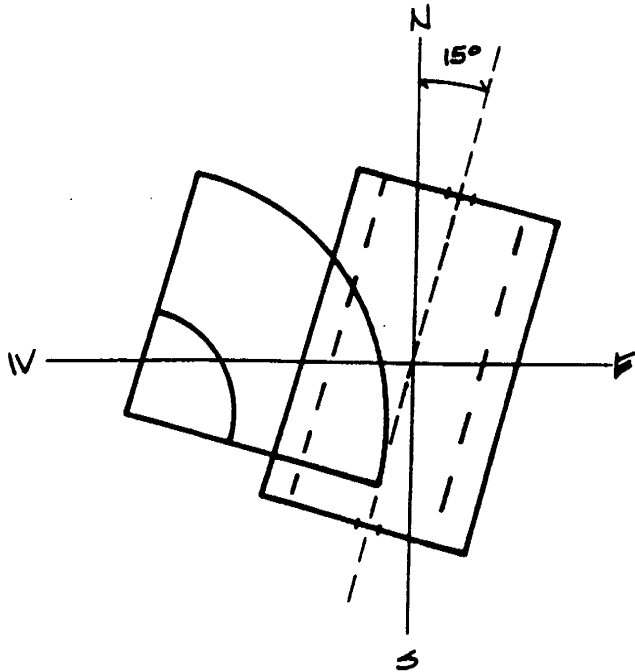

NOTES:

1. GOAL POSTS MAY REMAIN THROUGHOUT THE YEAR.
2. ORIENT SOCCER/FOOTBALL 15° N.E.
3. SITE SOCCER/FOOTBALL OUTSIDE 110' SKINNED AREA.
4. NO OUTFIELD OR FOUL LINE FENCING ON SOFT BALL.

KEY:

□ PRIMARY FIELD

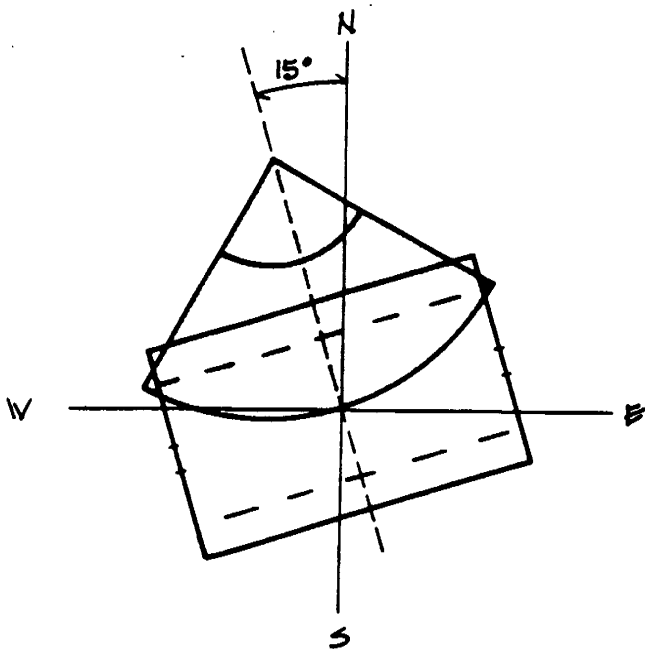

NOTES:

1. GOAL POSTS MUST BE REMOVED AT END OF SEASON.
2. ORIENT SOFTBALL 15° N.W.
3. SITE SOCCER/FOOTBALL OUTSIDE 110' SKINNED AREA.
4. DO NOT USE OUTFIELD OR FOUL LINE FENCING ON SOFT BALL.

SCALE: 1" = 200'

COMBINATION FIELD OVERLAYS

PARKS AND RECREATION FACILITIES
GUIDELINES © MANDPPC 1983

SOCCER/FOOTBALL

DEPARTMENT OF PARKS & RECREATION STANDARDS & SPECIFICATIONS, Prince George's County



Date Approved: 8/5/83

James E. Fuller Md. PIA # 387

Division of Planning, Design & Research

Drawn
MMM

Date
7/83

Revised

Date

MARYLAND NATIONAL CAPITAL
PARK & PLANNING COMMISSION

DETAIL

14

FOOTBALL FIELD

A football field should be used in areas where there is strong interest in football and organized leagues. A football field requires approximately 1-1/2 acres.

DESIGN REQUIREMENTS

1. Design Required - None

2. Size

Football Field - 360'x160' with standard goal post that is permanently installed. (Detail # **J1**)

3. Orientation

Directly north/south

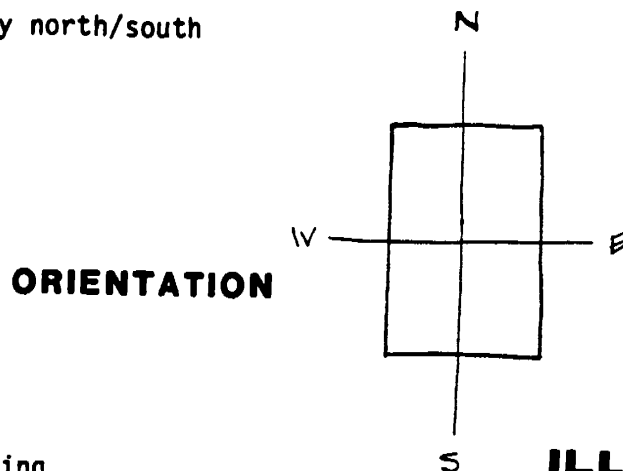

ILLUSTRATION # 14.1

4. Overlapping

Overlapping is acceptable if field is not to be heavily used for football or have tournament play. (If combination field is desired see football/soccer combination). Detail # **J4** .

5. Siting

Football/soccer field combinations are not to be sited in, on, or under any of the following:

- a. 10 year floodplain;
- b. Power lines;
- c. Manholes;
- d. Goal posts are not to be placed on any easements;
- e. Fields are to be set back a minimum 100 feet from access roads and property lines.

6. Drainage (Detail : **J3**) Minimum 2% slope, positive drainage.

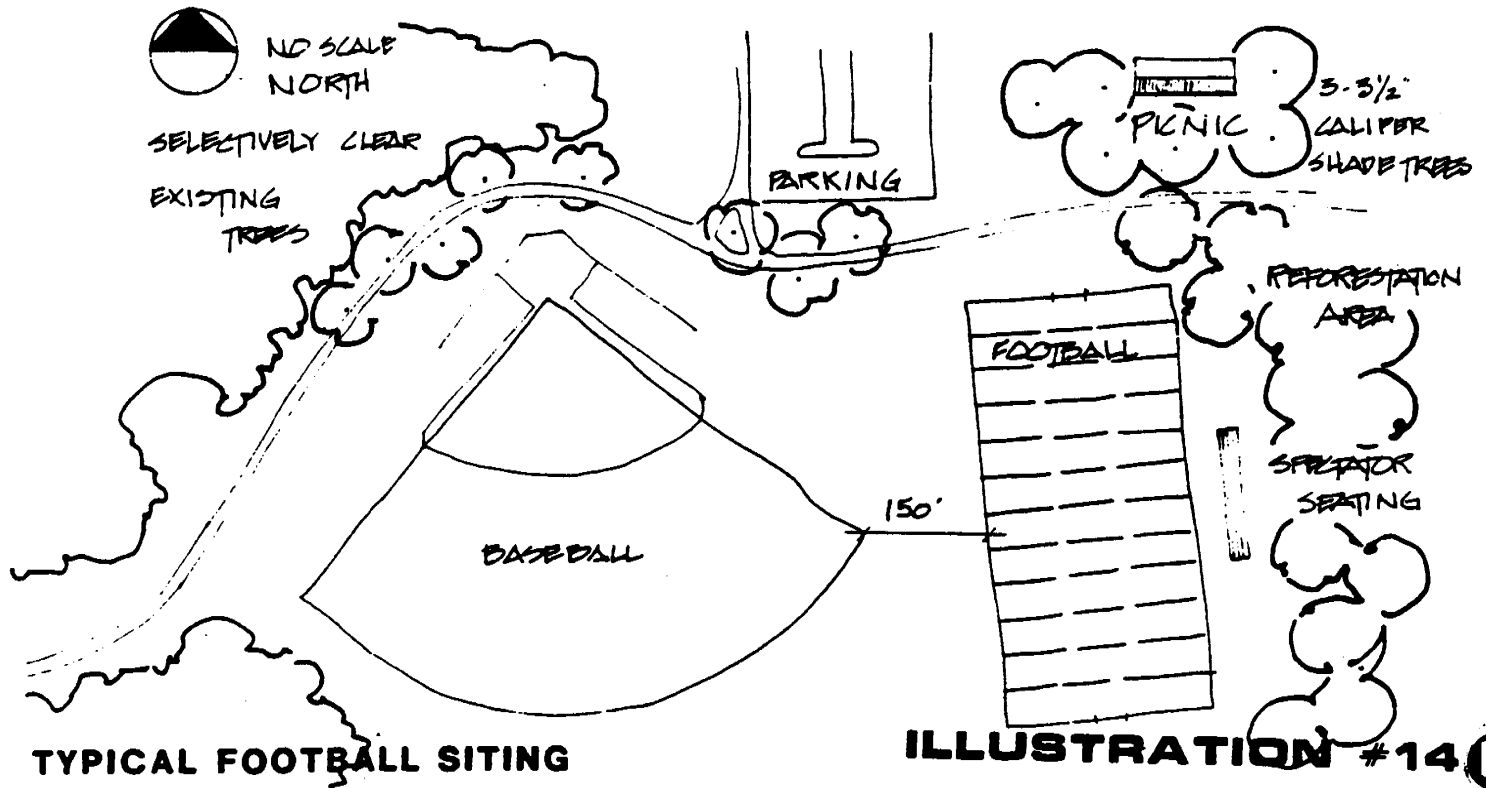

7. Goal Post

Use double standard

DESIGN OPTIONS

Suggested Additions to Improve Facility

A football field planned for a park that is programmed for league play must have seating.

Amount of Seating

Football teams have approximately 30 players per team (including managers, coaches, etc).

Player Benches - See Detail # **J1** for location. Seats should be wooden with galvanized legs anchored in concrete. Team seating may be on opposite sides or on the same side of the field.

Approximately 2/3 of players on the bench at once x 30"/player=25' of seating per team (may use any combination of length of benches) = 50' per field.

This length of bench will accommodate both adult touch football and boys' league tackle football.

Spectator Seating - Provision of seating for spectators and the amount of seating needed is dependent upon the following factors that the designer will have to weigh:

1. Type of games to be played (i.e. regular season playoffs, championships);
2. Type of park (sports, neighborhood, regional, community, etc.);
3. Age of players to use field youth leagues vs. adult.

General Rule of Thumb

It is better to provide too little seating as opposed to too much when providing bleachers, due to the high cost of the bleachers; however, an area should be left for expansion regardless of the type of seating. (Detail # J1)

A grass hill (maximum 3:1 slope approximately 5' high) will provide suitable seating for lesser used parks. Inclement weather will make grass seating undesirable at times.

If heavy use of fields is anticipated, provide an area(s) for spectator seating that is shaded.

Type of shade:

1. A grass hill planted with shade trees.
2. Bleachers with shade trees planted in proximity.
3. Architectural covering, i.e. awnings, canopies, etc.

Trees sited near the field should have 3 guys per tree, 120° apart. The first branch of trees should be pruned to allow free movement underneath. Trees should be a minimum of 2-1/2 to 3" caliper.

PLAN REQUIREMENTS

Written Specifications and Construction Details

Written specifications and details follow that are provided for construction of football fields. All fields are to be constructed in accordance with these specifications and details.

Preliminary Plat and Comprehensive Design Plan Requirements

The preliminary plat is to show the location of the football/soccer field(s) and its relationship to paths, property lines, parking and other recreational facilities.

Site Plan and Specific Design Plan Requirements

1. Site grading
2. Spot elevations
3. Landscaping
4. Paths
5. Buffering
6. Setback lines
7. Seating

Detail Sheet Requirements

1. Layout
2. Fencing
3. Entrances
4. Written specifications
5. Cross sections
6. Plan view

CONSTRUCTION SPECIFICATIONS

1. SCOPE

The contract work to be performed under this section consists of all the required labor, material, equipment, and services necessary to complete excavation and site work as shown on drawings prepared by the applicant. It includes excavating, pumping, back filling, and rough grading to elevations shown for completion of work, as hereinafter specified.

2. CLEARING SITE

The site development plan shows areas to be cleared.

(a) Clearing:

(1) Limits of clearing shall be confined to those areas as shown on the plans, or as required by the typical grading and paving sections. The clearing line is to be marked in the field by the contractor. Activity by the Contractor beyond these limits shall be at the authorization of the Engineer and/or Landscape Architect. At several locations, the grading may have to vary slightly to avoid destruction of specimen trees.

(2) Clearing shall include demolition and removal of all trees, saplings, brush, downed timber, shrubs, rotten wood, rubbish, vines, undergrowth, and any other vegetation from the area of game courts, walkways, and facilities. Clearing shall also include other trees as shown on the plans and so designated for removal. Demolition shall include root systems of trees, as well as the removal of fences and incidental structures.

(b) Grubbing:

(1) Limits of grubbing shall coincide with limits of clearing, unless otherwise specified.

(2) Grubbing shall include removing from the ground all stumps, roots and stubs, brush, organic materials, and debris within the limits of grubbing.

(c) Disposal:

(1) Burning of materials on site shall not be permitted.

(2) Where chips are to be utilized the trees may be chipped.

The following generally pertain to parkland development:

(3) All trees shall be thoroughly chipped and used as mulch on site. Chipped material shall be stockpiled on site as shown on the plans.

(4) The maximum size of chipped particles shall be three inches (3") in any dimension.

(d) General:

(1) The contractor shall visit the site to determine the existing conditions and shall be held responsible for all demolition covered under these specifications.

(2) The Contractor's attention is specifically directed to The Maryland Department of Transportation's Specifications, Section 31.01-12, Subparagraphs 1 and 7, referring to tree trimming and scar repairs.

(e) Field Quality Control:

(1) The Engineer and/or the Landscape Architect shall approve the clearing line prior to any clearing.

(2) After clearing and grubbing has been completed, the Engineer is to inspect damage to remaining trees and shall direct Contractor to have damage repaired by a professional tree surgery firm at no expense to the Owner.

(f) Demolition on Site:

(1) Protection to Persons and Property: All work shall be scheduled and executed in a careful manner with due consideration for workmen and the public, and to prevent injury to any persons or property.

(2) Use of Explosives: Do not do any blasting on the project site without written permission from the Engineer and unless it is done in accordance with applicable laws and regulations.

(g) Clean-Up:

(1) Remove from the site any stumps, dead trees, broken and loose branches, rubbish, and debris resulting from demolition, unless otherwise specified.

(2) Leave the site in a safe, clean condition.

(3) After demolition and removal work is completed, do not store on site any materials resulting from demolition or any tools and equipment used for work.

3. GRADING

The grading plan shows the extent of areas to be graded. All grades shall be in accordance with plans.

- (a) Soil Tests: Soil tests have not been made to determine the characteristics of the soil and the level of the water table, except as shown on the plans.
- (b) Subsurface Conditions: The Contractor is to examine information shown on the plans, and is to examine the site, making such tests as he deems necessary to determine the conditions and nature of the soil.
- (c) Bench Marks and Monuments: Carefully maintain all bench marks, monuments and other reference points. If disturbed or destroyed, replace as directed.
- (d) Finished Grades: Refer to the required grade elevations indicated. If finished grades shown by spot elevations conflict with those shown by contours, spot elevations shall be used. Unless indicated, the project site area shall be given uniform slopes between points for which finished grades are shown, or between such points and existing established grade, except vertical curves or roundings shall be provided at abrupt changes in slope. Do all grading required to bring the entire project area to finished grades.
- (e) Debris: Remove from the site all debris and excavated material not suitable, or not needed for fill.

4. SITE DRAINAGE

1. GENERAL

See Site Development Plan.

2. SCOPE

The contract work to be performed under this section consists of all the required labor, material, equipment, and services are to be provided, as necessary, to complete site drainage, as shown on the drawings.

5. TOPSOIL, SEEDING AND SOD

(a) Scope:

- (1) Sodding and seeding are to be as included in the contract.
- (2) The contract work to be performed under this section consists of all the required labor, material, equipment, and services necessary to install topsoil, as shown on the drawings or as specified herein.
- (3) The smallest practical area of land is to be exposed at any one time during development.

- (4) Make provisions to effectively accommodate the increased run off caused by changed soil and surface conditions during development.
- (5) Natural vegetation must be retained and protected.
- (6) The permanent final vegetation and structures must be installed as soon as practical in the development of this site.

(b) Topsoil:

- (1) Stripped topsoil is to be reasonably free of woody plants, stones over one inch (1") in size, construction debris, excavated material or deleterious matter.
- (2) Topsoil is to be approved by the Engineer and/or Landscape Architect before installation and is to consist of a sandy loam containing 2 to 2.5 organic matter free of debris, rock, and gravel.
- (3) Furnish and spread four inches (4") of topsoil over disturbed areas.
- (4) Spread evenly to true contours and hand rake to an even, smooth surface ready for seeding.
- (5) Regrade and fill low spots after shrinkage.
- (6) Existing topsoil, if acceptable, may be used as far as it will go. New topsoil is to be brought in, as necessary, to build up required grading. Any tests required to determine the quality of topsoil, both existing and new, will be made where, and as directed by, the Engineer and/or Landscape Architect, at no expense to the Owner.

(c) Seeding:

- (1) Grass seed shall be Maryland State Certified and mixed in the following percentages by weight:

<u>SEED</u>	<u>PERCENT OF MIX</u>	<u>PERCENT GERMINATION</u>	<u>PERCENT PURITY</u>	<u>PERCENT WEED SEED CONTENT</u>
Kentucky Bluegrass	10	75	85	.40
K-31 Tall Fescue	90	85	98	.50

(2) Seeding Operation

Seed shall be sown at the rate of 6 to 8 pounds/1,000 square feet, or 250 pounds per acre.

The seed shall be spread by mechanical spreaders at the rate previously specified. Seeding shall be done in two directions, the second being perpendicular to the first using one-half of the amount of seed in each direction. The seed shall be in firm contact with the seed bed and raked into the top one-fourth inch (1/4") of topsoil. The Contractor shall have the option of rolling the seeded into the topsoil, rather than raking. If the Contractor elects to roll, the roller shall weigh no more than 150 pounds.

- b. Fertilizer shall be a commercial chemical fertilizer 50% of the nitrogen of which is derived from natural organic sources of ureaform. The fertilizer shall contain the following percentages by weight:

20% nitrogen
20% phosphoric acid
10% potash

Fertilizer shall be applied at the rate of 220 pounds per acre to the areas to be seeded and sodded.

- c. Ground Limestone shall conform to MSHA, Article 20.05, Section 20.05-3.
- d. Water shall be clean and potable, suitable for drinking.
- e. Straw Mulch shall consist of thoroughly threshed wheat, rye, or oat straw.
- f. Binder Terra Tac AR or approved equal.

(d) Sod:

Sod shall be cultivated bluegrass-fescue mixture grown in an established turf nursery for at least two (2) years before lifting. Sod shall be free of insects, grubs, and apparent disease, and shall show proof of a current Nursery Inspection Certificate.

(1) Sod shall have been mowed prior to stripping and shall have been maintained for a minimum of three (3) months at or near the height of final clipping at the nursery. Maximum height: two and one-half inches (2-1/2").

(2) Sod shall be machine striped at a uniform soil thickness of approximately one inch (1"), plus-or-minus one-quarter inch (1/4"). Though thinner cuts tend to accelerate knitting and are, therefore, preferred, the minimum acceptable soil thickness shall be three-quarter inch (3/4"). Measurement for thickness shall include the growth and thatch.

(c) Individual pieces of sod shall be cut to the supplier's standard width and length. (Maximum allowable deviation from standard width and length is five (5) percent.) There shall be no broken pads, torn or uneven ends.

(d) In no event shall more than forty-eight (48) hours elapse between the cutting and planting of the sod.

(e) Before placing sod upon any surface, all shaping and dressing of such surfaces shall have been completed to grades on the plan. The completed areas to be sodded shall present a smooth, uniform, well tilled surface, and any raking required to accomplish this shall be done immediately prior to the placing of the sod.

(f) Sodding shall be performed during the proper season for such work. No frozen sod shall be used, and no sod shall be placed upon frozen soil.

(g) Maintenance - Sod shall be kept moist until it has become established, and its continued growth assured, or until accepted.

(h) Slopes - On slopes two-to-one (2:1) and steeper, sod shall be laid with the long edges parallel to the contour starting at the bottom of the slope. Succession strips shall be neatly matched, and all joints staggered or broken. When placing sod in drainage ditches, the length of the strip shall be laid parallel to the direction of the flow of the water.

(i) Each strip or section of sod placed on slopes two-to-one (2:1) and steeper, and surface drainage V-shaped or flat bottom ditches or gutters, shall be staked securely with at least two (2) stakes spaced not more than two feet (2') apart with the flat side against the slope. Stakes may be wood wedges and shall be 1/2" x 1" x 12" to 1/2" x 1" x 15" driven flush with the top of the sod.

(j) Guarantee - Sodded areas which do not show a prompt catch shall be resodded at no expense to the Owner.

(6) MULCHING

The mulch shall be applied over the seeded areas in an approved manner. The rate of application shall average 115 pounds per 1,000 square feet with a minimum of 90 pounds and a maximum of 140 pounds per 1,000 square feet, so as to provide a loose depth of not less than one and one-half inches (1-1/2") nor more than three inches (3").

Uniform distribution and depth of mulch must be obtained. After the mulch is in place, all mulched surfaces shall be sprayed with asphalt binder material so that the surface has a uniform appearance. The binder shall be applied to the mulch at the rate of eight (8) gallons per 1,000 square feet. A spray nozzle of approved design shall be used. The nozzle shall be operated at a distance of not less than four feet (4') from the surface of the mulch. A pump or air compressor of adequate capacity shall be used to insure uniform distribution of the bituminous material.

(7) TIME OF SEEDING AND SODDING

March 1 to May 1 and August 1 to October 31, inclusive.

(8) MAINTENANCE

The Contractor shall maintain all seeded and sodded areas for a period of not less than 45 days nor more than 60 days. Maintenance shall consist of watering, weeding, mowing, repairing of all erosion and settlement, and reseeding or resodding of lawn areas, as necessary, to establish a weed-free, dense, closely knit turf of the grasses specified.

At the time of the first mowing, mower blades shall be set between two and two and one-half inches (2-2-1/2"). All newly seeded and sodded areas shall receive at least three (3) mowings before acceptance of lawns. Remove all grass clippings during or immediately after mowing.

Maintenance shall also include any temporary protection fences, barriers, and signs, as well as all other work incidental to proper maintenance.

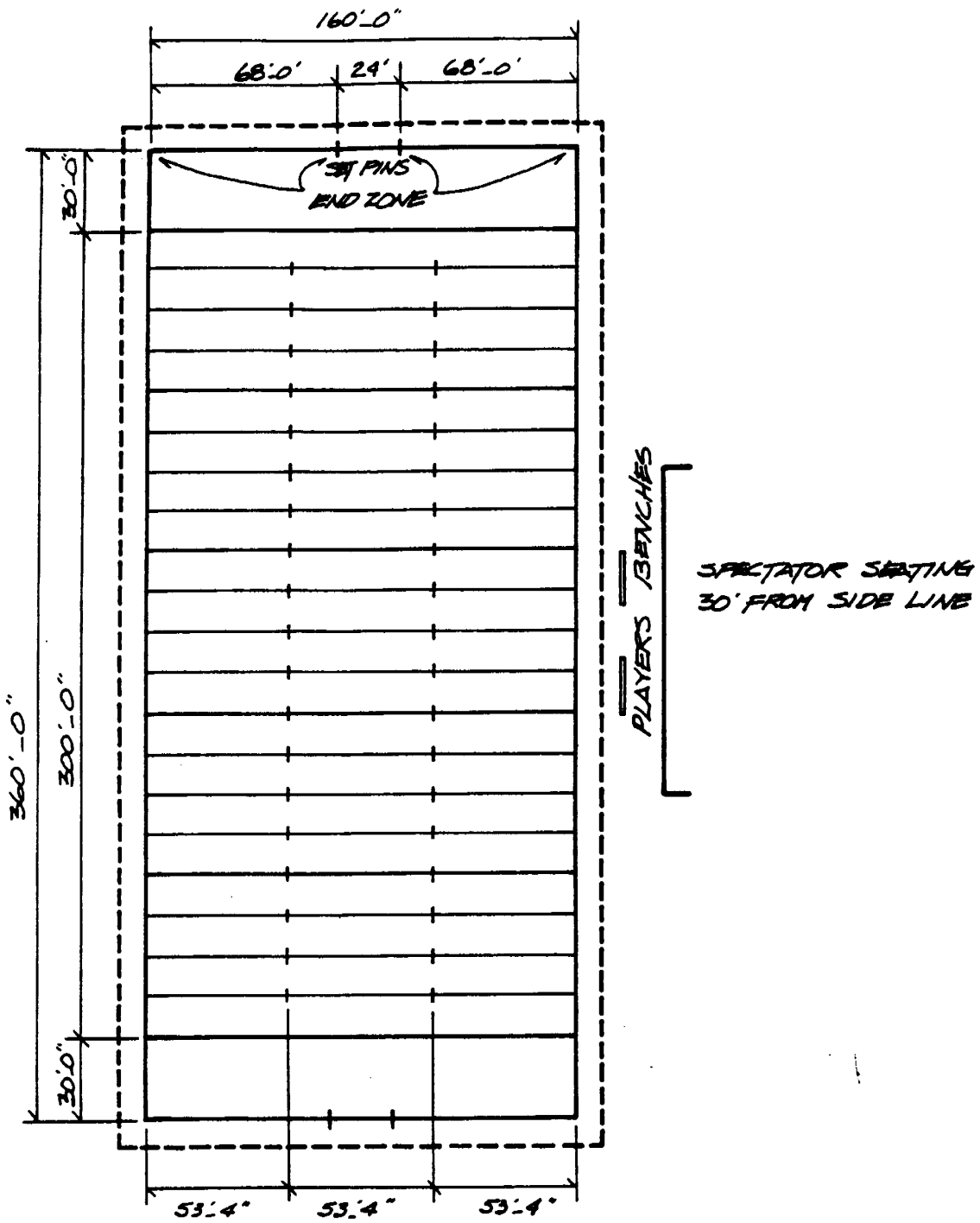

SCALE - 1" = 60'

FIELD LAYOUT

FOOTBALL

PARKS AND RECREATION FACILITIES
GUIDELINES © M-NDPPC 1983

DEPARTMENT OF PARKS & RECREATION STANDARDS & SPECIFICATIONS, Prince George's County



Date Approved: 0/3/03
Grace E. Fidler Hd. RLA #387

Drawn
MNM
GET

Date
7/03

Revised	Date

DETAIL
J1

Division of Planning, Design & Research

MARYLAND NATIONAL CAPITAL
PARK & PLANNING COMMISSION

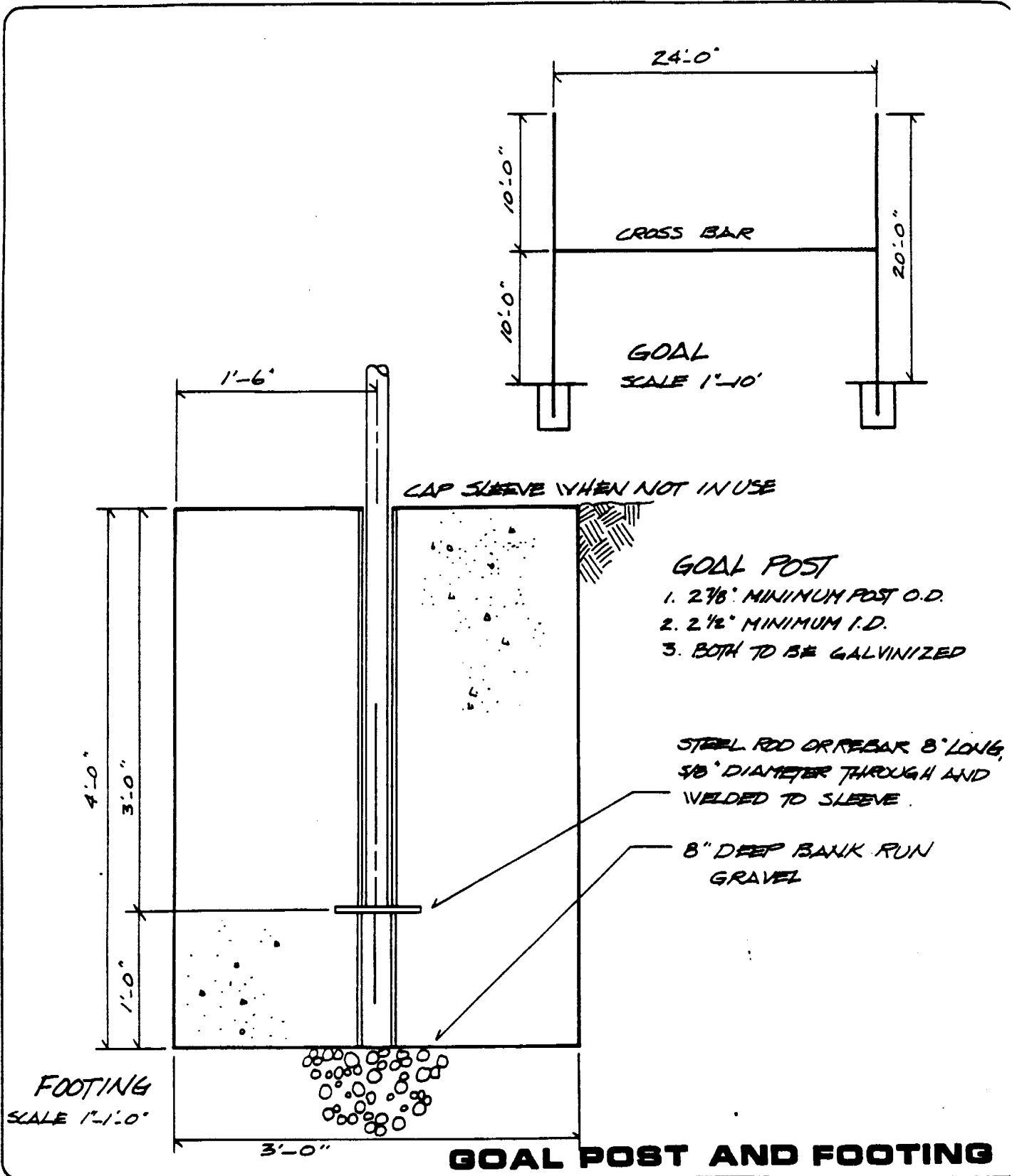

FOOTBALL

PARKS AND RECREATION FACILITIES
GUIDELINES © M-NDPPC 1983

DEPARTMENT OF PARKS & RECREATION STANDARDS & SPECIFICATIONS, Prince George's County



Date Approved: 8/3/83
Gene E. Fisher M. RLA # 387

Drawn
MMM
GEF

Date
7/83

Revised
Date

DETAIL
J2

Division of Planning, Design & Research

MARYLAND NATIONAL CAPITAL
PARK & PLANNING COMMISSION

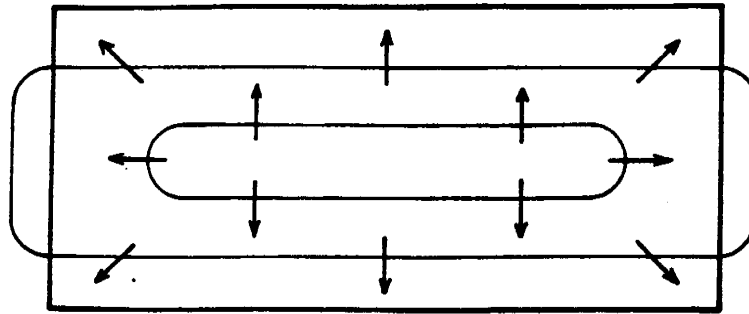

SIDE

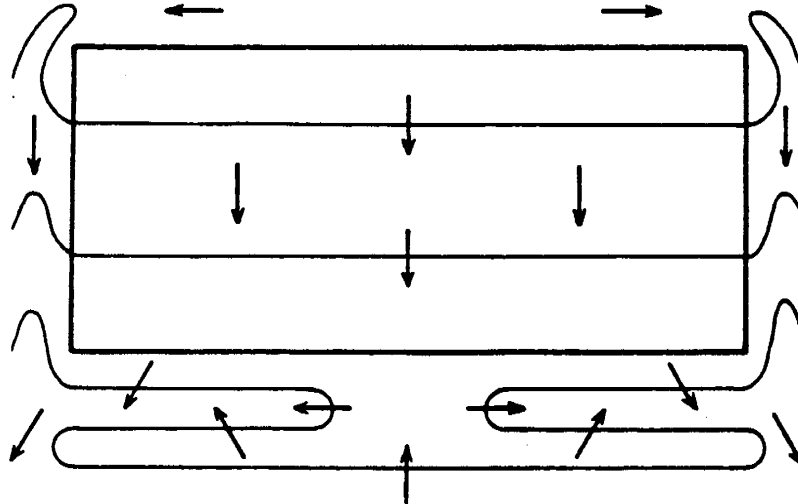

CROSS FIELD

NOTES

1. USE CROSSFIELD IN STEEP AREA AND ON COMBINATION FIELDS (SOFTBALL/FOOTBALL)

2. 2% SLOPE

SCALE: 1"=100'

DRAINAGE

FOOTBALL

PARCS AND RECREATION FACILITIES
GUIDELINES © MNC/PGC 1983

DEPARTMENT OF PARKS & RECREATION STANDARDS & SPECIFICATIONS, Prince George's County



Date Approved: 8/3/83

Gene E. Fuller Md. RLA #387

Drawn
MNM
GET

Date
7/83

Revised

Date

DETAIL

J3

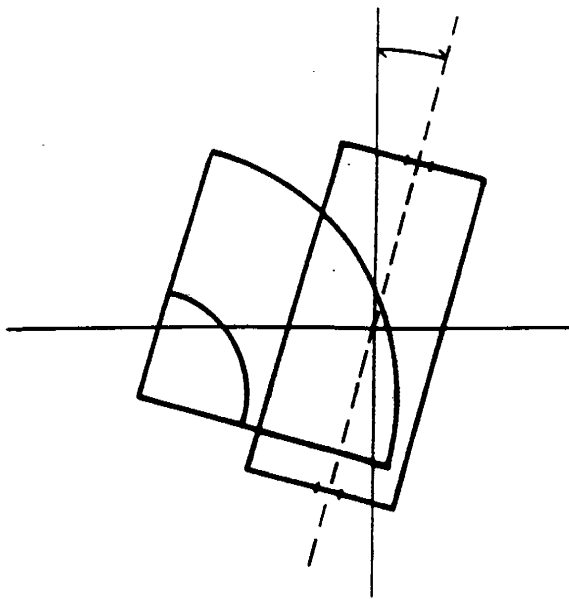

NOTES:

1. GOAL POSTS MAY REMAIN THROUGHOUT THE YEAR.
2. ORIENT FIELD 15° N/E
3. SITE FIELD BEYOND 110' SKINNED AREA
4. DO NOT FENCE FOUL LINE OR OUTFIELD OF SOFTBALL.

PRIMARY FIELD

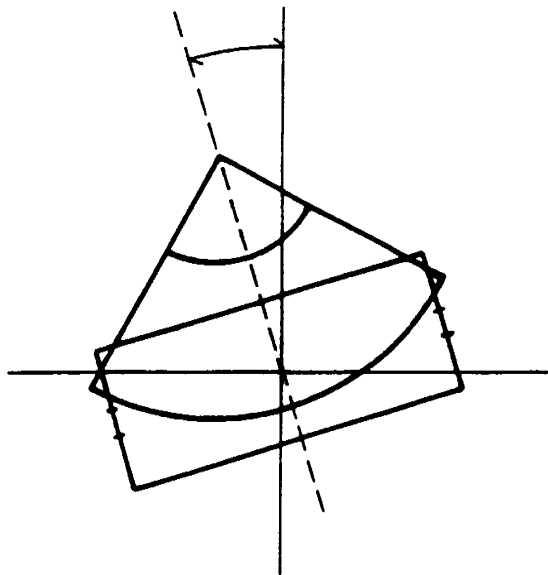

NOTES

1. GOAL POSTS MUST BE REMOVED AT END OF SEASON.
2. ORIENT 15° NW
3. SITE FIELD OUTSIDE 110' SKINNED AREA.
4. DO NOT FENCE FOUL LINE OR OUTFIELD OF SOFTBALL.

SCALE 1" = 200'

COMBINATION FIELD OVERLAYS

FOOTBALL

PARIS AND RECREATION FACILITIES
GUIDELINES © MNCPPC 1983

DEPARTMENT OF PARKS & RECREATION STANDARDS & SPECIFICATIONS, Prince George's County

MNC



Date Approved: 2/3/83

James E. Felder Md. RLA #387

Division of Planning, Design & Research

Drawn
MINM
GEF

Date
7/83

Revised	Date

DETAIL

J4

MARYLAND NATIONAL CAPITAL
PARK & PLANNING COMMISSION

TRAILS

Trails are used for bicycling, horseback riding, hiking, running, strolling and commuting. Projections indicate that utilization of trails are on the increase due to the variety of users that can share the experiences. The greatest barrier to trail development is finding suitable land. Obtaining the use of linear strips of land, particularly in urban areas, is a difficult task, however, many trails have and will continue to be developed through the County-wide Trails Plan adopted and approved in July 1975. The plan is currently being updated.

The Plan recommends the utilization of utility right-of-ways, powerlines, old railroad beds, existing parks, proposed parks, stream valley parks, city streets and private property to create a functional trail network for all users. The continuous implementation of the trail system has become an integral part of the land development process.

EASEMENT REQUIREMENTS

There are various classes of trails that require varying easements due to ownership. A list follows:

<u>Paths</u>	<u>Easement</u>
Subdivision	None
Park	None
<u>Trails</u>	
Fitness, Running	None
Nature	None
Equestrian	40'-50'
Hiking	15'
Biking	25'-35'
Hiker/Biker Equestrian Combination	75' to 85'

GENERAL TRAIL AND PATH DESIGN

1. Handicapped access is to be provided wherever possible, special considerations being given for wheelchairs.
2. All trails to be a minimum of 10' from stream bank edge.
3. Trails are to be clearly signed to indicate permitted and excluded uses. The M-NCPPC Sign Manual will contain information on proper signage. (Manual is being prepared).

Types of trails and their respective design and construction requirements follow.

PATHS-SUBDIVISION

Paths are to be designed to link proposed residences to recreational facilities, county trail systems, adjoining public parks and schools. Paths are a facility in and of themselves when property laid out.

DESIGN REQUIREMENTS

1. Required:

- a. Hardsurfaced paths are required in all townhouse developments, multifamily developments, Comprehensive Design Zones, and Recreational Communities to link recreational facilities with residences.
- b. Hardsurfaced paths will also be required in any development that proposes recreation facilities instead of payment of fee in lieu or dedication of land.

2. Size - 4' wide.

3. Surface Material

- a. Asphalt 2" SN on 3" CR6 on 95% compacted soil. Detail # **K1**.
- b. Concrete 4" with 6x6 #10 wire mesh in 4" concrete on compacted sub-base or 4" concrete on 4" of compacted CR-6. Detail # **K1**.
- c. Woodchips allowed only in densely wooded areas with minimum length of 400' a depth of 6" of wood chips is to be laid on cleaned and grubbed ground. Detail # **K1**.

4. Gradient

- a. Asphalt and concrete maximum 7% minimum (note details for limited distances that may exceed 7%) 1%, cross slope maximum of 1%. The path is not to be the drainage system.
- b. Woodchips maximum 3% minimum 1%, cross slope maximum 1% paths are to run generally parallel with contours and not perpendicular. (Perpendicular paths cause hillsides to erode).

5. Alignment and Clearing Detail # K2.

- a. Prior to any grading or clearing center line stakes are to be set. Any realignment from approved plans are to be field checked and approved by M-NCPPC. Prior to installation of paths all efforts are to be made to save existing trees.
- b. Tree limbs overhanging the path are to be removed to 10' and all dead trees adjoining the path are to be removed for safety. The 4' path is to have a 2' shoulder on both sides for a total clearing of 8'.

6. Stream Crossings

Bridge crossings are to be breakaway bridges either metal or pressure treated wood. Stream crossings should be avoided wherever possible due to the expense involved. Pre-fabricated bridges can be purchased or designer may provide bridge design for review and approval.

7. Steps

Steps in path systems are to be avoided. Steps are to be used in areas of extreme grade changes only. Risers are to be 6" and treads 15" and in minimum groups of 2. Steps are not to be used in areas that are meant to be accessible to the handicapped. Details are to be included on plans for steps. Timber steps are to be pressure treated. Concrete is the most desirable step when they must be provided.

DESIGN OPTIONS

Trash receptacles, sitting and picnic areas can be located along paths. Trash receptacles should only be placed in areas where trash pick-up can be readily made to keep the site clean. Subdivision paths may be modified to be exercise and/or nature trails more detailed descriptions appear on later pages under those headings.

PATHS-PARK

Paths are to be designed to link proposed park facilities with parking lots and other countywide trail systems. Park paths are frequently used by maintenance vehicles (trash trucks, dump trucks, mowers, etc.) and require a greater depth of paving and base course in addition to width of paving to prevent breakage.

DESIGN REQUIREMENTS

1. Required

Hardsurfaced paths are required for all parks in areas of heavy use (remote woodland areas may not need hardsurfaced paths) to reduce the amount of long term maintenance and erosion.

2. Size

8' wide

3. Surface Material

- a. Asphalt - 3" SN on 4" CR6 on 95% compacted soil. Detail #K 1.
- b. Concrete - 4" with 6x6" 10 wire mesh on 95% compaction, gravel size CR6 may be required if ground conditions are mushy. Detail #K 1.
- c. Woodchips - are not to be used in parks unless in a densely wooded remote area. Chips to be applied at a 6" depth on an area that has been cleared and grubbed. Detail #K 1.

4. Gradient

- a. Asphalt and concrete maximum 7% minimum 1% cross slope of 1%. Path is not to be the drainage system.
- b. Woodchips maximum 3%, minimum 1% cross slope maximum 1%. Paths are to run generally parallel with contours and not perpendicular (perpendicular paths erode).

5. Alignment and Clearing Detail #K 2

- a. Prior to any grading or clearing, center line stakes are to be set, any realignment from approved plans are to be field checked and approved by Engineer and/or Landscape Architect prior to installation. All efforts are to be made to save existing trees.
- b. Tree limbs overhanging paths are to be trimmed to 12' and all dead trees and branches removed from trees adjoining paths, this will promote park user safety. The 8' path is to have 2' compacted grass shoulders for a total clearing of 12'. The entire path system should have a general feeling of openness to encourage use and discourage loitering.

6. Stream Crossings

Bridge crossings are to be flotation bridges either metal or pressure treated wood. Stream crossings should be avoided wherever possible due to the high cost of the item. When stream crossings are necessary they must be sufficiently large to carry emergency vehicles, unless the area is otherwise readily accessible by vehicle.

7. Fords

Concrete fords may be utilized in areas of low flow for vehicular crossing.

8. Steps

Steps in path systems are to be avoided whenever possible. Steps are to be used only when areas of extreme grade make it necessary. Steps are then to be 6" in height with 15" treads and a minimum of 2 at a time.

9. Accessories

Trash receptacles, sitting and picnic areas can be located along trails. Trash receptacles should only be placed in areas where trash pickup can be easily made to keep the site clean. Park paths may be modified to be fitness or nature trails more information can be found under those headings.

TRAIL RUNNING/FITNESS

A fitness and/or running trail is to be designed to provide a balanced spectrum of physical exercise along a path or trail system. The fitness trail may be either a primary or secondary facility. The trail needs to be very visible (for safety), marked and have both a starting (warm up) and finish (cool down) area.

DESIGN REQUIREMENTS

1. Required

None for subdivision

2. Surface Material

Grass, asphalt, concrete, woodchip base must provide a firm footing for runners. Always include area for dirt runners.

3. Distance Covered

Fitness trails will be of varying lengths depending on their importance as a facility and the site itself. Minimum 1/4 mile.

4. Primary Trail

Trail should be a minimum of one mile, 5280' with 20 stations. This does not include the start and finish. A full length trail is best utilized when large acreages and stream valleys are involved. Stations should be appropriately sited and chosen to give the user time to warm up and stretch the muscles to prevent injury.

5. Secondary Trail

This trail can be of any length with a minimum of 10 stations with a start and a finish. The stations are to be placed a minimum of 200' apart. This trail will be approximately 1/4 mile in length.

6. Fitness Area

Highly undesirable but a cluster of stations can be designed for maximum exercising in a minimum amount of space.

7. Topography

Maximum 7% gradient for trail and minimum of 1%. Stations to be set on level well drained area.

8. Clearing

An area of minimum 10' radius from the station is to be cleared and branches trimmed to 10'. The area is to be covered with 4" of woodchips.

9. Accessories

If trail is entirely in the sun and over 1/2 mile in length a shaded sitting area should be provided at each 1/2 mile point. Mileage markers can be placed by or painted on trail.

10. Signage

Use visible markers for mileage and stations to indicate the start and finish of trail. If hardsurfaced trail mileage can be painted on trail surface. If a commercial fitness package is purchased signage will probably be included.

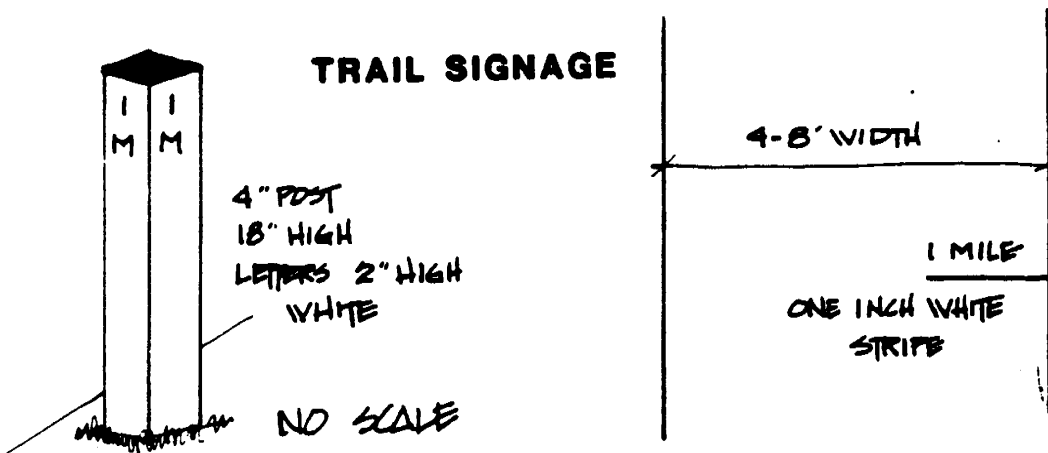

ILLUSTRATION # 15.1

TRAIL NATURE

The name nature trail denotes a quite learning experience and can only be successfully sited in a large subdivision or park. (Minimum of 20 acres)

DESIGN REQUIREMENTS

1. Required

None for subdivision.

2. Surface Material

Dirt, grass, asphalt, woodchips, width of trail - 4 to 6' with appropriate clearing.

3. Distance Covered

Will vary drastically with the material to be covered. The trail may be for tree identification, small woodland plants or ecological systems, or a combination of this or many others. Nature trails should not be restricted to wooded areas but should include fields, meadows, swamps, bogs, ponds and areas of reforestation. Designate an area on the plan of development for nature study and label with the following quote:

"Area to be reserved for nature trail. Trail is to be sited in field by Engineer and/or Landscape Architect and Naturalist prior to installation of system."

Highlight areas on the site plan of specific interest, point out what needs to be preserved and what the areas of interest are to be.

4. Topography

The gradient of the trail will be very dependent upon what type of "nature" is being interpreted, however, use the rule of thumb of a maximum 7% grade minimum 1%.

5. Signage

Use visible markers that include description of ecological systems, and botanical as well as common names. Signage can be very site specific and designed to fit a particular site.

6. Specifications

Site development plan is to contain specific information as to what and how something is to be interpreted. The specifications are also to include size, type and a detail for the signage.

7. Period of Construction

Environmentally sensitive areas must be protected during construction from traffic, erosion, sedimentation, construction debris, etc. Snow fencing is to be placed around areas for protection. Refer to the section of the manual on Landscaping under Tree Preservation.

TRAIL EQUESTRIAN

The equestrian trail is one of the least expensive trails to construct, however, great care must be taken in the siting and design of the trail for proper horse and rider safety. Adequate topography and tree cover are desirable

to provide for a variety of experiences of closed and open spaces. The trail easements should have sufficient width to provide a variety of visual experiences as well as riding experiences. Width of easement is dependent upon the terrain and footing for the horses.

Trails in parks are tied to other systems, a concession should provide at least one closed riding circuit. A 20 mile trail takes 3 to 4 hours to ride.

DESIGN REQUIREMENTS

1. Subdivision - 40' easement to be provided in areas that have relatively gentle slopes less than 1% and no floodplain.

50' easement to be provided in areas of loose footing (i.e., gravel, sand) steep slopes and floodplain. Subdivision are to use standards for parks when designing and/or constructing trails.
2. Park

Trails to be sited in appropriate parks and stream valleys. Site the trail a minimum of 15' from property lines, 25' from recreation facilities, and 20' from hiking and/or biking trails.
3. Size

Trail width will vary between 10' and 20'. 20' stretches of a minimum of 1/2 mile in length are to be provided to allow for riders to canter in company, or converse. These areas are to be provided in suitable areas. It is best to secure the assistance of an experienced trail rider when designing a trail system.
4. Surface Materials
 - a. Natural turf that is not swampy, or filled. Areas that must be filled need 95% compaction to prevent erosion.
 - b. Dirt is very suitable if area is not highly erodible and is relatively level 5%.
 - c. Rock areas and loose gravel are to be avoided. These areas are difficult for the horse to ride through making it unsafe for riders.
 - d. Gravel, asphalt and concrete are undesirable except to handle certain conditions.
5. Clearing Detail # **K2**
 - a. Width - clear a total width of trail plus 2' on either side i.e., 10' + 4' equals 14'. Remove all dead trees and branches that could fall on trail.

- b. Height - Clear a total height of 12', removing all dead trees and branches.
- c. Field Checks - Minimize all areas where surprises may occur that would frighten horses.

6. Visibility

- a. Trail - provide approximately 200' in both directions.
- b. Road crossings - are extremely dangerous.
 - 1. 1/8 mile visibility required from off road at crossing point.
 - 2. Existing bridge crossings should be utilized whenever adequate headroom (10') is available.
 - 3. Horse crossing signs and cross walks are to be provided.
 - 4. Walk light may be needed in heavily travelled areas (i.e., Route 1, Indian Head Highway or Maryland Route 301).

7. Stream Crossings

- a. Natural fording is preferred to a bridge crossing. Always consult a experienced trail rider.
- b. Stream bottom should be stable, free of large rocks, soft mud and debris.
- c. The ford should have a gravel base heavy enough not to wash away and the stream should be shallow enough so any debris can be seen.
- d. Ramps leading down to the streams should have 2:1 maximum slope made of gravel and 15' wide.

8. Bridges

Use only in extreme situations, horses become very skittish. Rider can ford under bridge.

9. Screening and Buffering from Residences and Roads

Provide trees and shrubs to buffer horse trails from residences and roads.

10. Gradients

Horses ride on almost any grade but trails that are perpendicular to the contour - no matter how minimal the slopes are to be avoided because of erosion. Site trails parallel to the contours. If trails are to be used by novice riders, avoid areas of extreme grade changes.

4. Support Facilities

The following should be included at trail heads.

1. Saddling areas with hitching posts and/or hitching rings screwed into trees and rails for saddles;
2. Loading and unloading areas for horses;
3. Watering area (every 10 miles) trough must be drainable to prevent possible disease spread;
4. Hitching area (to tie up horses for rest);
5. Parking lots for vehicles, trucks and trailers;
6. Signs, gates;
7. Emergency phone;
8. Emergency vehicle access periodically along trail.

TRAIL HIKING

Hiking trails should be designed to fit the user and the situation. It must be determined from the onset if the trail is to be used for "tramping" or "sight seeing", what numbers of people are involved and whether or not its family groups, hikers, strollers, etc.

DESIGN REQUIREMENTS

1. Required

- a. Subdivision - 15' - 4' compacted trail surface, 1' of clearing on either side of trail and the remaining width will be utilized for buffer.
- b. Park - 4' trail may be sited appropriately in a park at a minimum of 10' from property lines and 10' from facilities. Providing connection to facility separately.

2. Surface Material

- a. Grass and compacted earth are the most desirable. Grass is to be kept at a maximum of 3" height. Dirt trails should only be used in relatively flat (7%) non-erodible areas and compacted, loose surfaces are tiring to walk through.
- b. Compacted gravel, cinder and clay are also desirable. Maximum slope on trail is 7%.
- c. Loose, swampy and uneven surfaces should be avoided. These areas include but are not limited to rock, gravel, sand and wet floodplains.

Short 200' stretches may be included in trail system if absolutely necessary.

3. Gradients

- a. Minimum 1%, maximum 7% with short segments of 10' to 250' of maximum 25% slope.
- b. Trails to be parallel to contours and maximum of 1% cross slope.

4. Clearing Detail # **K2**

- a. Overhead 10' remove all dead trees and branches.
- b. Width 4' plus 1' shoulder on either side.

5. Accessories

Trail can be designed to include:

- a. Picnic area;
- b. Sitting area;
- c. Nature trail;
- d. Fitness trail.

TRAIL BIKE

Bike trails are very similar in nature to road networks. The systems have feeders, collectors and arterials. The hierarchy of trails is to be kept in mind by the designer to avoid dangerous hiker/horse and biker conflicts. These three uses require different trails because of their very nature. Another important consideration is the starting and stopping point of the trails. Use Countywide Trails Plan adopted and approved in 1975 as a reference.

DESIGN REQUIREMENTS

1. Required

- a. Subdivision - 25' easement for trail to be constructed outside area of steep slope and floodplain
35' easement required in areas of steep slope and floodplain to allow more flexibility in trail design.
Trail criteria is to be used when designing bike trail.
- b. Park - none

2. Width

8' wide asphalt trail with 2' compacted grass shoulder on one side of trail and 4' compacted shoulder 10' wide at tunnels and bridges on other side.

3. Surface Material Detail #K1

Paving - 3" of SN, BF or equal on 4" of 95% compacted CR6 on 95% compaction of dirt. Depth of gravel base course will vary with soil conditions, test boring will be needed to determine soil conditions.

4. Preliminary Design

Points of consideration:

- a. Free and safe movement of trail users;
- b. Limited vehicular traffic movement for emergency, maintenance and patrol vehicles;
- c. Storm drainage and bridge installation;
- d. Significant cut and fill grading operations;
- e. Audio-visual plant buffers for privacy and separation from adjacent residential land owners and for protection and security purposes.

5. Setbacks

- a. Dwelling lot line to easement 20'.
- b. Property line to easement 0'.

6. Design Criteria

Speed:

- 10 miles per hours minimum
- 15 miles per hours preferred.
- 20 miles per hour downgrades.

7. Curvature Radius:

<u>Speed</u>	<u>Radius</u>
10 miles per hour	15 feet
15 miles per hour	35 feet
20 miles per hour	70 feet

8. Stopping Sight Distances:

Sight Distances for Downhill Gradients of:

<u>Speed</u>			
10 miles per hour	0%	5%	10%
15 miles per hour	50 feet	50 feet	60 feet
20 miles per hour	85 feet	90 feet	100 feet
	130 feet	140 feet	160 feet

9. Grades

- a. 10% if less than 50 feet
- b. 5% if less than 300-foot maximum
- c. 100 feet preferred
- d. 2% if less than 1,500 foot maximum 500 feet preferred.

10. Clearance

- a. Overhead 12' remove all dead trees and branches.
- b. Width - trail 8' plus 4' shoulders clearance.

11. Guard Rails

Minimum of two horizontal rails on bridges and other structures as required top rail to be 4' above ground, bottom rail 2' above ground.

12. Dropped Curbs

To be 8' wide inclined surface that meets roadway surface without vertical break.

Accessories

1. Trail markers refer to M-NCPPC Sign Manual;
2. Signage refer to M-NCPPC Sign Manual;
3. Benches for resting in shade;
4. Picnic area;
5. Bike racks;
6. Trail drop off points.

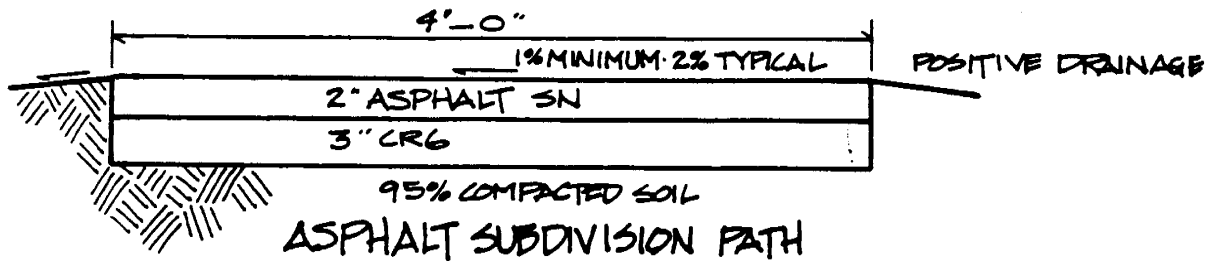
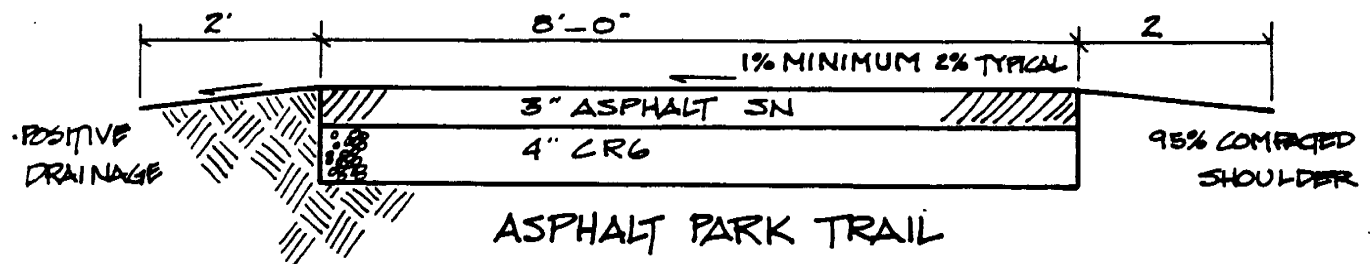
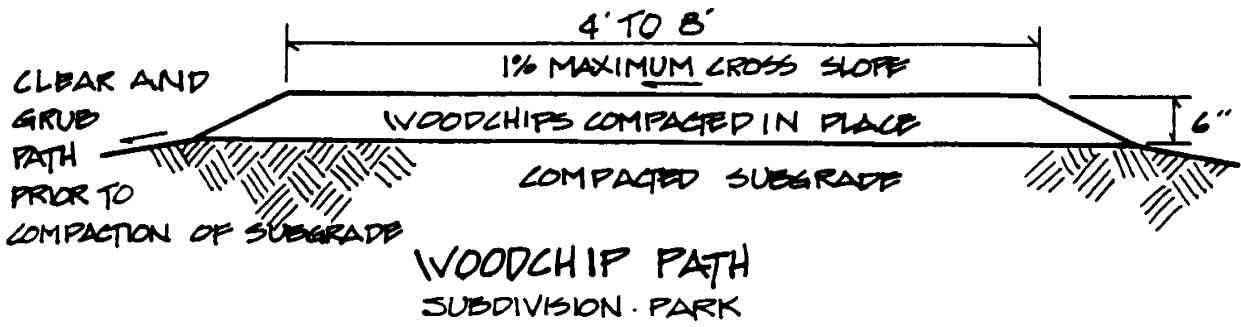
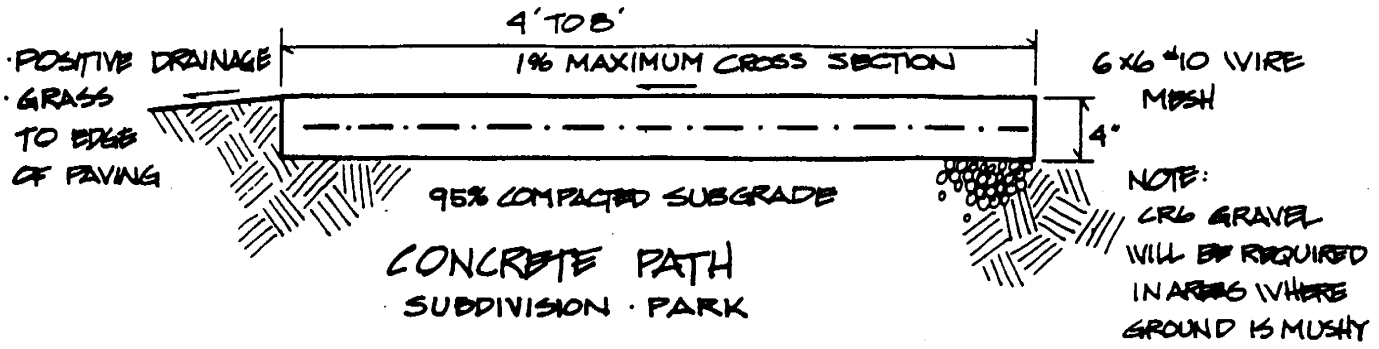

NO SCALE

PAVING CROSS SECTIONS

PARKS AND RECREATION FACILITIES
GUIDELINES © 14-1077C 1983

TRAILS

DEPARTMENT OF PARKS & RECREATION STANDARDS & SPECIFICATIONS, Prince George's County



Date Approved: 8/3/83
Quinn E. Fadden Md. RLA #387

Drawn
MNM
GET

Date
7/83

Revised	Date

DETAIL
K1

Division of Planning, Design & Research

MARYLAND NATIONAL CAPITAL
PARK & PLANNING COMMISSION

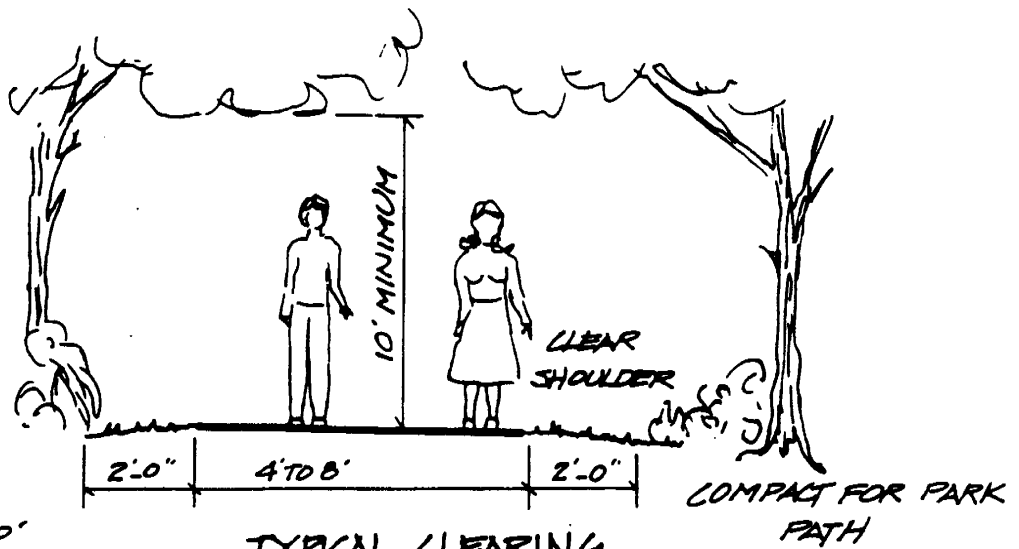

NOTES:

1. REMOVE ALL LIMBS AND BRANCHES TO 10'
2. PROVIDE POSITIVE DRAINAGE AWAY FROM PATH.

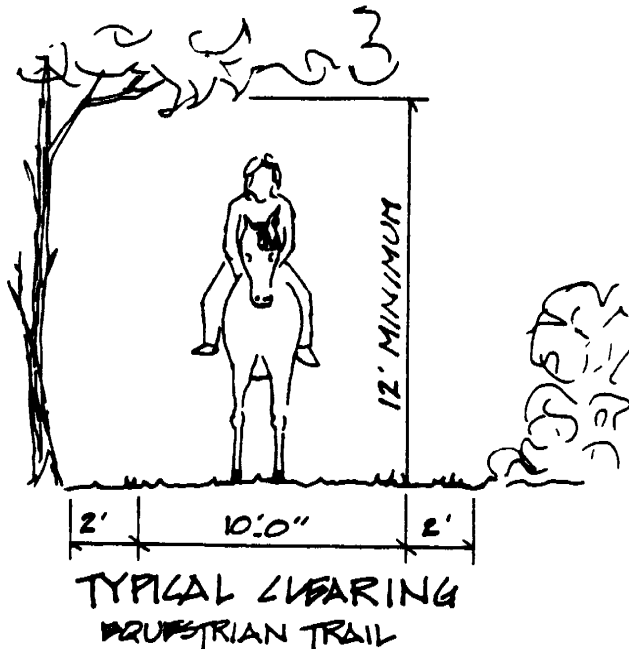

NOTES:

1. REMOVE ALL BRANCHES AND LIMBS TO 12'.
2. PROVIDE POSITIVE DRAINAGE AWAY FROM PATH.

NO SCALE

CLEARING CROSS SECTION

TRAILS

PARKS AND RECREATION FACILITIES
GUIDELINES © M-NCPPC 1983

DEPARTMENT OF PARKS & RECREATION STANDARDS & SPECIFICATIONS, Prince George's County



Date Approved: 8/5/83

Grace E. Fisher Md. RLA #387

Division of Planning, Design & Research

Drawn
MAM
GAT

Date
7/83

Revised

Date

MARYLAND NATIONAL CAPITAL
PARK & PLANNING COMMISSION

DETAIL

K2

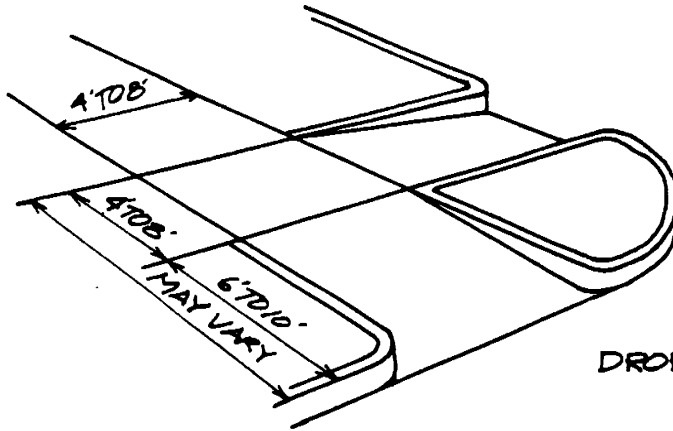

DROPPED CURB RAMP

TRAIL OR PATH AT STREET INTERSECTION

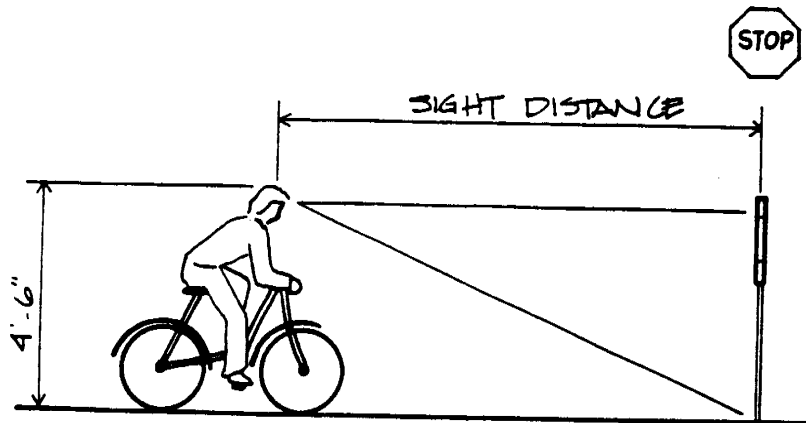

THE STOPPING SIGHT DISTANCE DEPENDS ON THE RIDER, GRADE OF PATH, AND THE COEFFICIENT OF FRICTION OF THE PAVEMENT.

STOPPING DISTANCE

CURB RAMP, STOPPING DISTANCE

TRAILS

PARKS AND RECREATION FACILITIES
GUIDELINES © MNCPPC 1983

DEPARTMENT OF PARKS & RECREATION STANDARDS & SPECIFICATIONS, Prince George's County



Date Approved: 8/3/83
Gene E. Felder Md. RLA #387

Drawn
MNM
GEF

Date
7/83

Revised

Date

**DETAIL
K3**

Division of Planning, Design & Research

MARYLAND NATIONAL CAPITAL
PARK & PLANNING COMMISSION

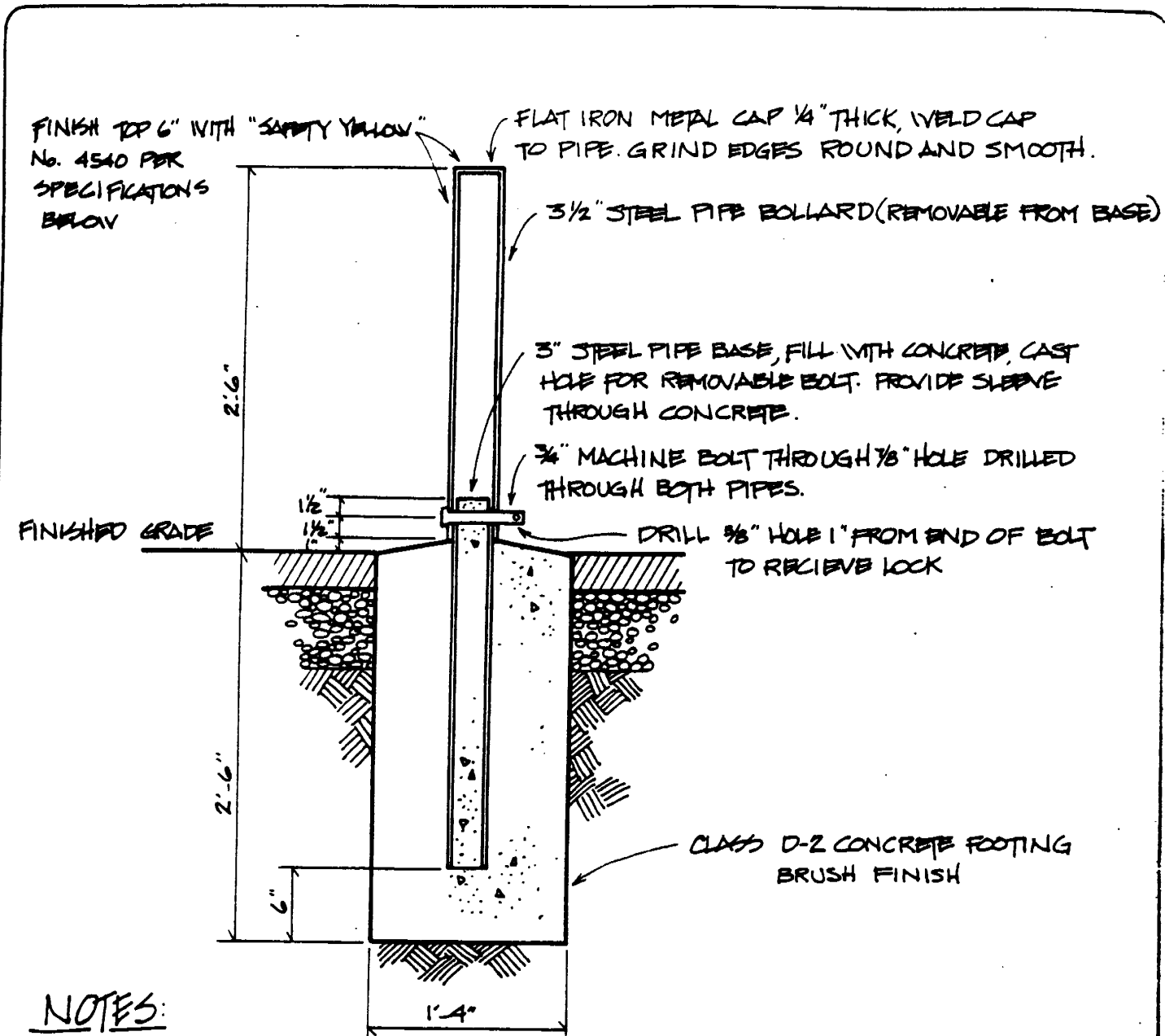

FINISH TOP 6" WITH "SAFETY YELLOW" No. 4540 PER SPECIFICATIONS BELOW

FLAT IRON METAL CAP 1/4" THICK, WELD CAP TO PIPE. GRIND EDGES ROUND AND SMOOTH.

3 1/2" STEEL PIPE BOLLARD (REMOVABLE FROM BASE)

3" STEEL PIPE BASE, FILL WITH CONCRETE, CAST HOLE FOR REMOVABLE BOLT. PROVIDE SLEEVE THROUGH CONCRETE.

3/4" MACHINE BOLT THROUGH 7/8" HOLE DRILLED THROUGH BOTH PIPES.

DRILL 5/8" HOLE 1" FROM END OF BOLT TO RECEIVE LOCK

CLASS D-2 CONCRETE FOOTING BRUSH FINISH

NOTES:

1. GRIND ALL EXPOSED SURFACES SMOOTH AND FREE FROM BURRS. PAINT ALL EXPOSED SURFACES WITH 2 COATS "GLIDDEN GLIDGUARD" ALKYD INDUSTRIAL ENAMEL "WARM BROWN" No. 4537 OR APPROVED EQUAL. TOP 6" "SAFETY YELLOW" No. 4540.
2. GRIND OUTSIDE SURFACE OF 3" PIPE AS NECESSARY TO ASSURE EASY REMOVAL OF 3 1/2" CAP.
3. ALL PIPE TO BE STANDARD WEIGHT PER AISC STEEL MANUAL.

SCALE 1"=1'-0"

SPECIAL REMOVABLE BOLLARD

TRAILS

PARKS AND RECREATION FACILITIES GUIDELINES © M-NCPPC 1983

DEPARTMENT OF PARKS & RECREATION STANDARDS & SPECIFICATIONS, Prince George's County



Date Approved: 8/3/83
Grace E. Filler Md. RLA # 387

Drawn MNM GET	Date 7/83	Revised	Date
---------------------	--------------	---------	------

**DETAIL
K4**

MARYLAND NATIONAL CAPITAL PARK & PLANNING COMMISSION

LANDSCAPING

Landscape plantings and tree preservation are as important to recreation areas, as they are to the total housing development. A thorough knowledge of plant materials and their growing habits is a must if the planting plan is to function properly and be an asset to the project as the plants mature.

Basic principles of design are to be adhered too in developing the planting plan for a recreation area(s) or a series of open spaces. A brief review of the function of plants in the landscape will highlight the assets of landscaping. Plants function as four distinct elements in the design process although historically we have only thought of the beautification. Plants provide controls in the following areas: climatic, engineering, architectural and aesthetics. A brief discussion of each aspect and illustration of its relationship to recreation is provided for your information and review.

LANDSCAPE DESIGN PRINCIPLES

CLIMATE CONTROL

1. Sun:

- a. Plants can reduce or screen solar radiation. plants w/rough, dark surface absorb heat and reduce transfer of heat from one area to the next.
- b. Absorb heat after it hits reflection surface.
- c. Absorb heat before it heats reflective surface.

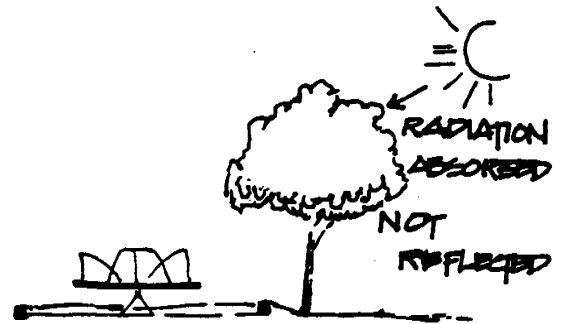

2. Wind

- a. Obstruct and/or reduce velocity of wind by increasing resistance.
- b. Prevailing wind NW in winter
- c. Prevailing breeze SW in summer
- d. Filtrate wind to speed up or slow down
- e. Guide wind
- f. Deflect away from area by dense screening

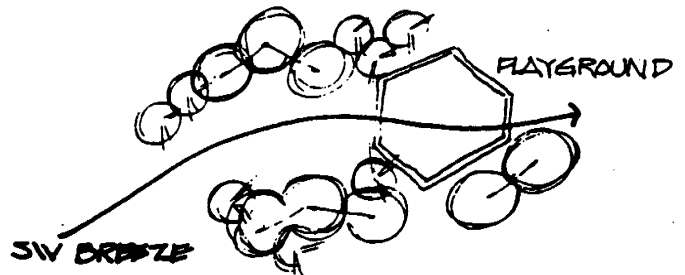

3. Precipitation Control

- a. Preserve and retain moisture in soil to modify temperature
- b. Intercept precipitation to modify temperature
- c. Intercept snowflakes
- d. Direct wind to blow area clean of snow

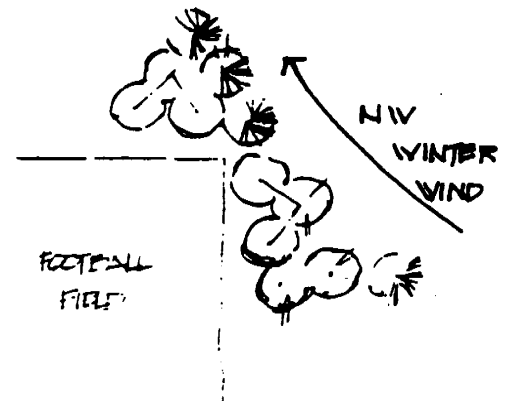

4. Temperature Control

- a. Deciduous trees cool in summer; allow heat in winter
- b. Dead air insulators; row of ever-green next to wall prevents loss of winter heat-creates air space between wall and trees.
- c. Shade tree underside-cooler than radiated side.

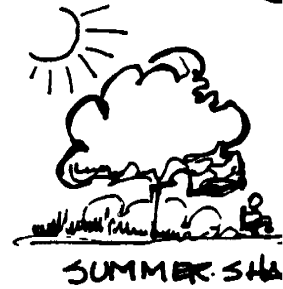

ENGINEERING

1. Erosion Control

A. Wind

Wind picks up small particle of soils
four parts or plants control wind erosion

1. Dense leaves or needles to form barrier to air movement
2. Dense branching slows wind close to ground
3. Multi-stems and roughbark decrease velocity
4. Fibrous roots, close to surface form mat.

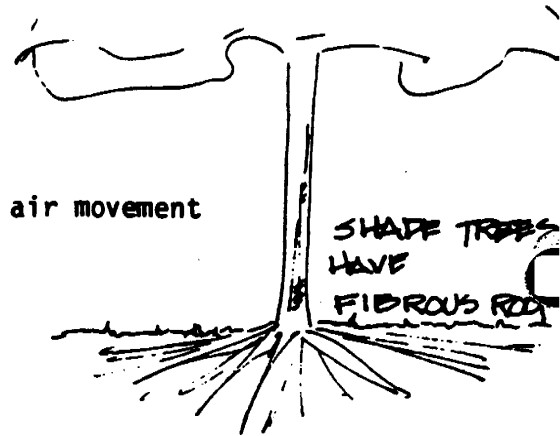

B. Water erosion (most common)

Utilization of plants in the following manners will stop eroision.

1. Leaves and branches form canopies to intercept raindrops to prevent splash erosion.
2. Roots form fibrous masses to hold soil
3. Leaves and dead parts of plants, increase the organic material in soil which increases water absorption and decreases run-off.

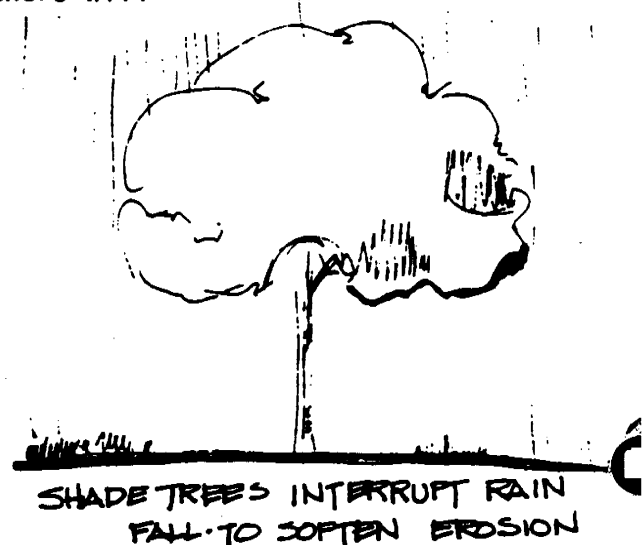

ARCHITECTURAL

C. Acoustical Control

Sound waves can be carried by wind.
Unwanted sound is noise

Types of noise

1. transportation
2. recreation
3. commercial
4. residential

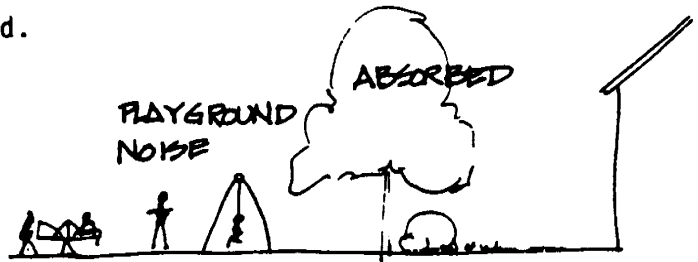

Control noise by:

1. Absorption - flexible and soft plant will entrap and absorb
2. Reflection and deflection - trunk and heavy branches reflect and deflect noise to source
3. Refraction - branches dissipate, disperse and diffuse sound
4. Glare and reflection
 - a. Stop reflection completely before it hits reflective surface; stop after it hits reflective surface.
 - b. Stop glare completely, diffuse glare.

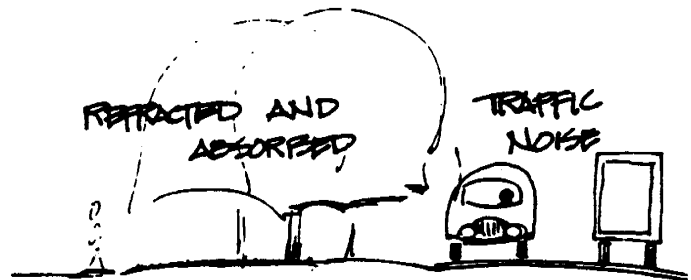

AESTHETICS

1. Complimentary, individually or group can compliment an existing element
2. Attractors
 - a. People to colors, textures, fragrances, shade, beauty
 - b. Attract birds and animals to nuts, shelters, fruits, berries

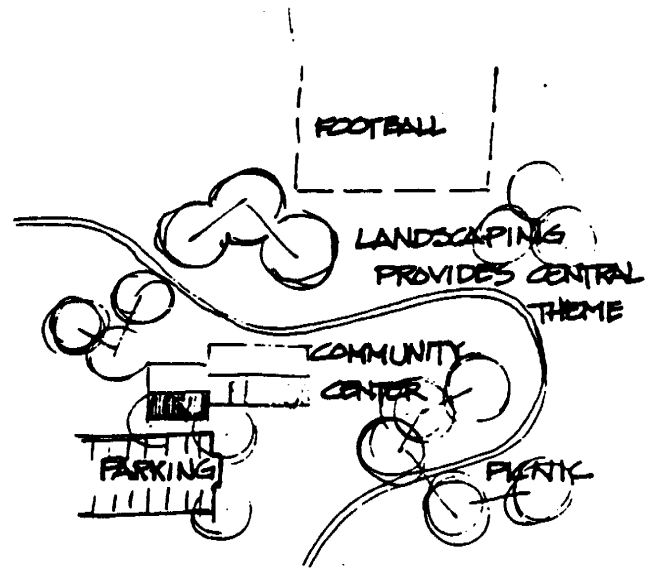

3. Unifiers

Pull together disparate elements and organize divergent parts of scene or facilities

4. Emphasizers

Accent a important element
(building facility, etc)
"this is it"

5. Evocators

Evoke memories of other
times, places, people

6. Two dimensional elements

- a. The shadow of a plant may create lines, patterns, textures, to set moods, etc.
- b. Add line shape to two dimensional plane



ATTRACT BIRDS, ANIMALS, PEOPLE
IN NATURE AREAS

7. Three dimensional object

- a. Visual controllers frame view, mask view, control perspective
- b. Color trunks, leaves, branches, etc. for each season
- c. Textural-smooth, polish, add depth to landscape experience
- d. Sculpture-use plant to make its own statement.

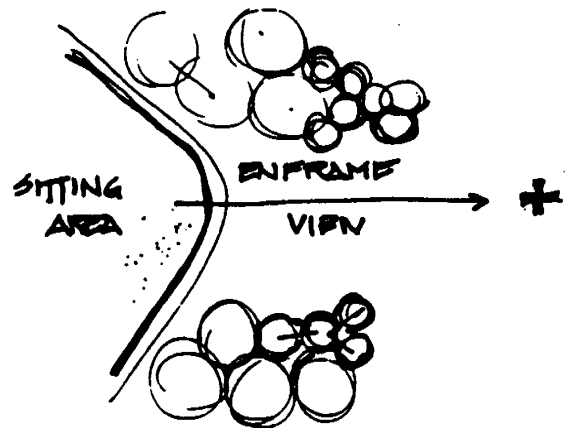

The Funtional Uses of Plant Materials - Plants, People and Environmental,
Quality by Gary O. Robinette.

DESIGN REQUIREMENTS

The department requires shade trees in the following four facilities:

- tot-lot (3 to 3-1/2" caliper shade trees) 4/area
- pre-teen lot (3 to 3-1/2" caliper shade trees) 5/area
- sitting area (2-1/2 to 3" caliper shade trees) 3/area
- picnic area (2-1/2 to 3" caliper shade trees)

The shade trees being provided in these areas should be high branching 8' (don't use pin oak, sweet gum) or trees with low trash - Shag-Bark Hickory, London Plane Tree).

Planting time and guarantee

Mid-March to Mid September plants to be guaranteed for 1 year.

Specification

Trees to be planted in accordance with the Specifications for Landscape Contracting by Natural Landscape Contractors, Inc.

Shade trees suitable for required landscaping*

Acer rubrum - Red Maple and varieties
Acer saccharum - Sugar Maple
Cercidiphyllum japonicum - Katsura Tree
Cladastris lutea - Yellow Wood
Fagus grandifolia - American Beech
Fraxinus americana - White Ash
Gleditsia triacanthos inermis - Moraine Honey Locust
Tilicordata - Littleleaf European Linden
Zelkova serrata - Zelkova
Quercus borealis - Red Oak
Quercus alba - White Oak

- * This is only a partial list of the trees available in nurseries, most of these trees are native and have good rates of growth, transplant easily and have a low trash production of fruit, leaves and berries.

TREE PRESERVATION

Tree preservation is an integral part of effective site analysis and utilization. Mature trees can never be replaced by smaller new trees and produce the same results as peelings. The Manual for Tree Preservation in Development Areas for Prince George's County provided by M-NCPPC published in June of 1982, guidelines on when, where and how to save valuable trees.

Mature trees add to planned recreation facilities and areas. Trees to be preserved in a recreation area to provide shade are to be identified by species name and size on the site plan.

The following is a brief outline for the tree preservation:

TREE PRESERVATION PROCEDURES

1. Existing trees which appear on this plan are to remain and shall be marked by the contractor using yellow surveyors tape wrapped about the trunk at 4-ft. height. (marking of trees is to be approved by M-NCPPC.)

2. Prior to any activity with any area represented on this plan, the project limit line (limits of disturbance) is to be staked in the field and approved by M-NCPPC. Existing trees indicated on this plan within the 30-ft. depth landscape buffer zone are to remain undisturbed and shall be encircled with snow fencing for protection. Snow fencing shall be a minimum of 4-ft. in height securely fastened to 6-ft. ht. steel posts which shall be driven 18-in. into the ground and spaced a maximum of 6-ft. on center. The fenced areas shall be regarded as off limits for construction activities; except, where minor grading must occur within the fenced area it shall be completed without the use of mechanical equipment of any sort. And, grading activity shall be minimized within the fenced area.
3. The contractor shall diligently undertake to prevent the removal of or damage to any tree which is designated for preservation. Damage or destruction of any such tree shall be the responsibility of the contractor whether caused by the contractor, his agents, employees, sub-contractors or licensees. Examples of ways in which trees are damaged or destroyed are as follows:
 - a. Placing backfill in protected areas
 - b. Felling trees into protected areas
 - c. Driving construction equipment into or through protected areas
 - d. Burning in or in close proximity to protected areas
 - e. Stacking or storing supplies in protected areas
 - f. Changing site grades which cause drainage to flow into, or to collect in protected areas
 - g. Conducting trenching operations in the vicinity of trees
 - h. Grading in the vicinity of trees
4. All trees which are not to be preserved are to be removed in a manner that will not damage those trees which are to remain. Any trees that are to remain that have been damaged during the clearing operation must be repaired in an approved manner by a MARYLAND LICENSED ARBORIST (tree expert) as soon as final clearing has been completed.
5. After construction is completed, temporary barriers, surplus materials and all trash, debris and rubbish shall be removed from the site. All backfill shall be clear of building material, stone and rubbish.

6. Penalty Clause

If it is determined that the contractor has failed to comply with the tree preservation procedures above, and has damaged or removed any trees which were designated for preservation, the contractor will be required to compensate for the loss by either of the following:

Tree Preservation Area

The contractor, at his own expense, shall compensate by planting one 2-1/2-in. - 3-in. caliper tree for every 4-in. caliper increment of the tree destroyed.

i.e.,

If a 36-in. White Oak is destroyed, it shall be replaced by nine (9) 2-1/2-in. - 3-in. caliper trees (36-in. \div by 4 = 9).

Note: The nine (9) trees shall be in addition to the trees required in the table shown on the Landscape Plan.

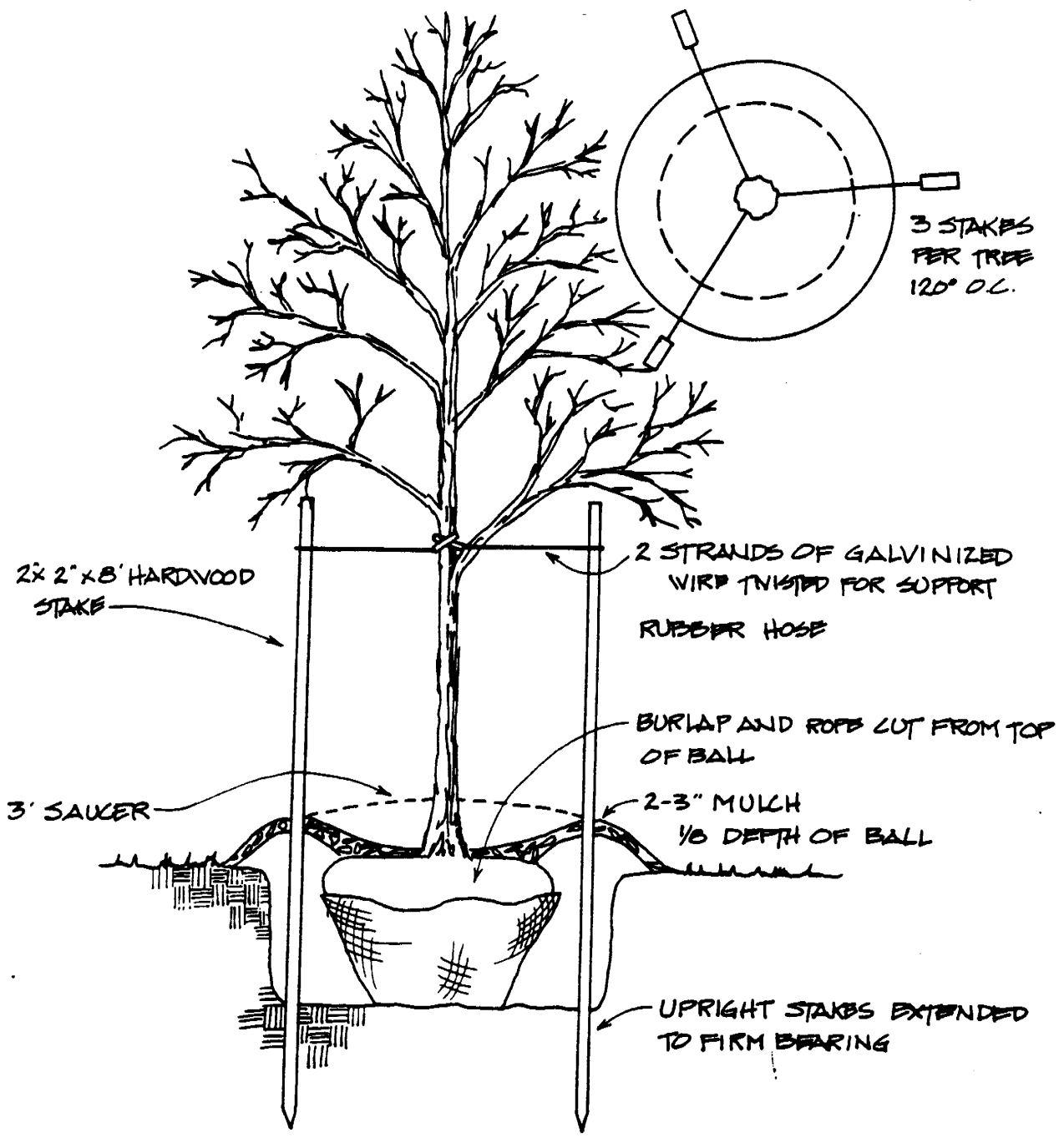

NO SCALE

SHADE AND EVERGREEN TREE PLANTING

LANDSCAPING

PARKS AND RECREATION FACILITIES
GUIDELINES © M-NCPPC 1983

DEPARTMENT OF PARKS & RECREATION STANDARDS & SPECIFICATIONS, Prince George's County



Date Approved: 8/3/83

Gene E. Fuller M.D. P.L.A. # 387

Division of Planning, Design & Research

Drawn
MNM ~~687~~

Date
7/83

Revised	Date

DETAIL
L1

MARYLAND NATIONAL CAPITAL
PARK & PLANNING COMMISSION

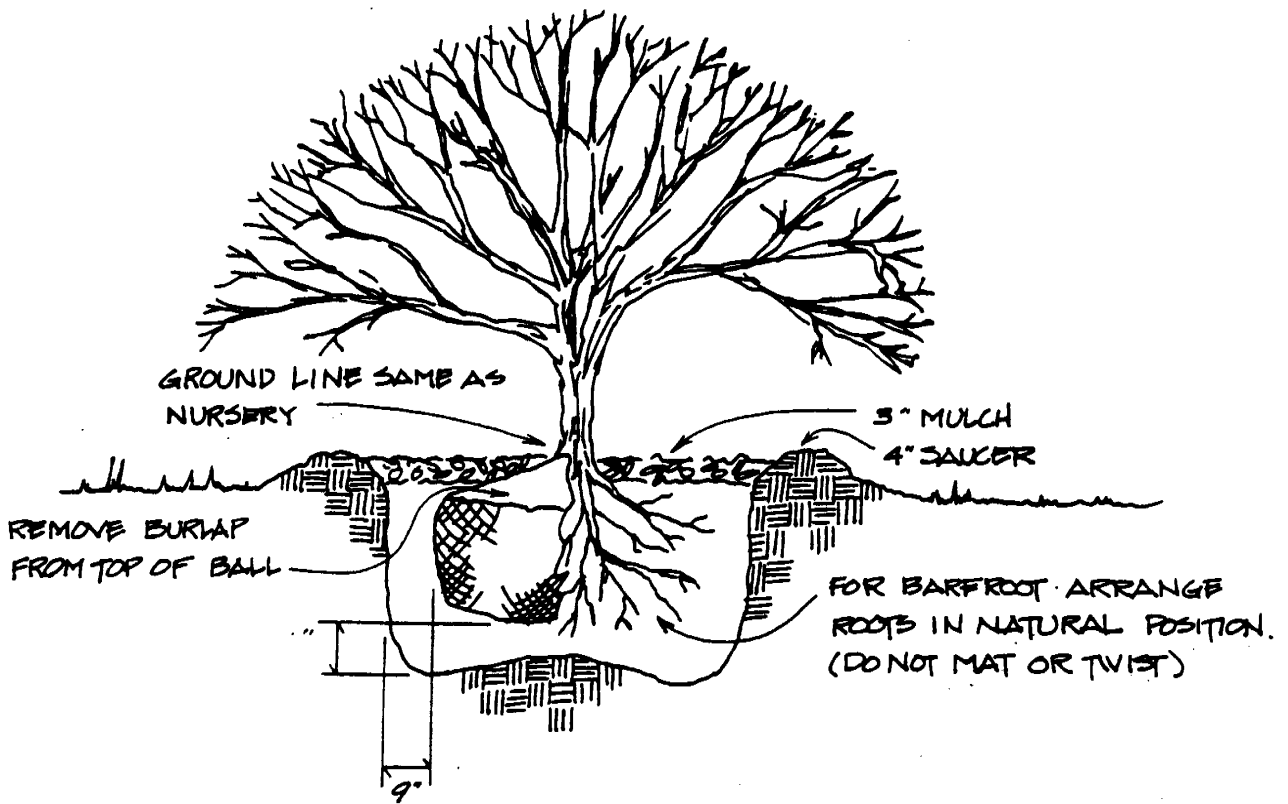

NOTE:
 EVERGREEN AND DECIDUOUS SHRUBS
 TO BE PLANTED IN SAME MANNER.

NO SCALE

SHRUB PLANTING

PARKS AND RECREATION FACILITIES GUIDELINES © M-NDPPC 1983		<h1>LANDSCAPING</h1>				<h2>DETAIL</h2> <h1>L2</h1>
DEPARTMENT OF PARKS & RECREATION STANDARDS & SPECIFICATIONS, Prince George's County						
	Date Approved: <u>0/3/83</u>	Drawn: <u>MNMGR</u>	Date: <u>7/83</u>	Revised: _____	Date: _____	
	<u>Queen E. Fuller Md. RLA #387</u>		MARYLAND NATIONAL CAPITAL PARK & PLANNING COMMISSION			
Division of Planning, Design & Research						